

Report of Waste Discharge

Peninsula Community Services District
Wastewater Treatment Facility
Samoa, California



Prepared for:

Peninsula Community Services District



January 2019
017201.005

Report of Waste Discharge

Peninsula Community Services District Wastewater Treatment Facility Samoa, California

Prepared for:

Peninsula Community Services District

Prepared by:



812 W. Wabash Ave.
Eureka, CA 95501-2138
707-441-8855

January 2019

QA/QC: MKF___

Table of Contents

| | Page |
|--|------|
| Abbreviations and Acronyms | ii |
| 1.0 Introduction | 1 |
| 1.1 Phase 1 Components | 2 |
| 1.1.1 Wastewater Collection System | 2 |
| 1.1.2 Town of Samoa Wastewater Treatment Plant | 2 |
| 1.1.3 Treated Water Disposal | 2 |
| 1.1.4 Solids Dewatering and Disposal | 3 |
| 1.2 Phase 2 Components | 3 |
| 2.0 Report of Waste Discharge: RWQCB Form 200 | 3 |
| 3.0 General Information: EPA Form 1 | 3 |
| 4.0 Supplemental Information: EPA Form 2D | 3 |
| 5.0 Sewage Sludge Production and Disposal Information: EPA Form 2S | 3 |
| Appendices | |
| 1. RWQCB Form 200: Report of Waste Discharge | |
| 2. EPA Form 1: General Information | |
| 3. EPA Form 2D: Supplemental Information | |
| 4. EPA Form 2S: Supplemental Information | |
| 5. Preliminary Design Report | |

List of Illustrations

| | |
|--|----------------|
| Figure 1. Proposed Wastewater Treatment System Diagram | Follows Page 3 |
|--|----------------|

Abbreviations and Acronyms

| | |
|-----------------|---|
| EIR | environmental impact report |
| EPA | Environmental Protection Agency |
| Harbor District | Humboldt Bay Harbor, Recreation and Conservation District |
| LCP | Local Coastal Plan |
| NPDES | National Pollutant Discharge Elimination System |
| PCSD | Peninsula Community Services District |
| PVC | polyvinyl chloride |
| RMT II | Redwood Marine Terminal II |
| ROWD | report of waste discharge |
| RWQCB | North Coast Regional Water Quality Control Board |
| SBR | sequencing batch reactor |
| TSS | total suspended solids |
| UV | ultraviolet |
| WDRs | waste discharge requirements |
| WWTF | wastewater treatment facility |

DRAFT

1.0 Introduction

SHN, on behalf of the Peninsula Community Services District (PCSD), is submitting the following report of waste discharge (ROWD) and National Pollutant Discharge Elimination System (NPDES) permit application for the proposed wastewater treatment facility (WWTF) project located in the Town of Samoa, Humboldt County, California. The PCSD is applying for coverage under a North Coast Regional Water Quality Control Board (RWQCB) NPDES permit to discharge treated municipal wastewater to the Pacific Ocean through the existing ocean outfall located at the Redwood Marine Terminal II (RMT II), also located in Samoa.

As a part of this NPDES permit application, the following forms are being submitted:

1. RWQCB Form 200: Report of Waste Discharge (Appendix 1)
2. Environmental Protection Agency (EPA) Form 1: General Information (Appendix 2)
3. EPA Form 2D: New Sources and new Discharges Application for Permit to Discharge Process Wastewater (Appendix 3)
4. EPA Form 2S: Sewage Sludge Production and Disposal Information (Appendix 4)

The proposed ocean discharge location is through the ocean outfall located at RMT II, also known as the former Samoa Pulp Mill. The RMT II ocean outfall is owned and operated by the Humboldt Bay Harbor, Recreation, and Conservation District (Harbor District). The Harbor District has agreed to lease access to the ocean outfall to the PCSD for the discharge of treated municipal wastewater; however, there is no written lease agreement at this time.

The proposed project would result in construction and operation of a consolidated wastewater collection, treatment, and disposal system for residential, commercial/industrial, recreational, and institutional facilities located within the boundaries of the PCSD. A preliminary design report has been prepared for the proposed project (Appendix 5). The project would provide wastewater service to the unincorporated communities of Fairhaven and Finntown; however, the project would not provide service to the Samoa Townsite as described in the approved Samoa Townsite Master Plan. The project would be implemented in the following phases:

Phase 1

Phase 1 includes construction and operation of a wastewater collection system, upgrades to a previously approved wastewater treatment plant, and a disposal system to serve the existing development within the boundaries of the PCSD.

Phase 2

Phase 2 would allow future infill development, consistent with existing Local Coastal Plan (LCP) and zone, within the PCSD boundary to connect to the project's collection system and be served by the wastewater treatment plant.

Each project phase is discussed in detail below.

1.1 Phase 1 Components

As stated above, Phase 1 of the proposed project would allow sewer service to existing development within the boundaries of the PCSD. Phase 1 of the proposed project includes the following components:

- Collection System: wastewater lines installed within the existing road rights-of-way
- Upgrades to the previously approved WWTF: secondary treatment facility in the Town of Samoa with a sequencing batch reactor (SBR) system followed by ultraviolet (UV) disinfection
- Treated Water Disposal: ocean outfall line at the RMT II site
- Solids Treatment and Disposal: onsite dewatering using a polymer injection system and a roll-off style dewatering container

1.1.1 Wastewater Collection System

The proposed wastewater collection system consists of gravity flow pipes in the communities of Fairhaven and Finntown, connected by a single pressure pipe running north to a centralized WWTF near the Town of Samoa. Gravity pipes would be a minimum diameter of 8 inches to allow for easy access of cleaning and inspection equipment. Manholes would be placed a maximum of every 500 feet, at each change in vertical or horizontal alignment, within existing rights-of-way and streets, and at the end of every pipe run. Gravity mains and laterals would be constructed to prevent floatation during seismic events or due to high groundwater.

Each community would have at least one centralized pump station to pump raw wastewater to the WWTF through the central pressure main. The pressure main would include air relief valves at each high point in the pipeline with air scrubbers to remove noxious gasses and odors. These filters and lines to the air relief valves shall be regularly maintained and cleaned. The pressure main would also include cleanout stations at each change in horizontal or vertical alignment, intersection of main lines, and at the end of every pipe run, for launching of a pipeline inspection gauge to clean the pipe when necessary. The wastewater in the system would be conveyed to the proposed Town of Samoa WWTF location.

1.1.2 Town of Samoa Wastewater Treatment Plant

The project would result in the construction of upgrades to the previously approved WWTF in the Town of Samoa. The WWTF has not been constructed, but was analyzed in the certified Samoa Townsite Master Plan environmental impact report (EIR); State Clearinghouse Number 2003052054. The WWTF upgrades would include a primary treatment system for raw wastewater, involving screening and grit removal, followed by secondary treatment consisting of an SBR. Effluent would be disinfected with a UV system. For solids handling the proposed project would dewater the solids using a batch process onsite.

1.1.3 Treated Water Disposal

Effluent from the WWTF would be transported to the ocean outfall located at RMT II for ocean disposal. A pressurized effluent pipeline with one pump station would be constructed from the WWTF to Manhole 5 (located at RMT II) for connection to the ocean outfall. The effluent pipeline would be installed beneath existing roadways to minimize environmental impacts. To easily handle all future flows a 6-inch polyvinyl chloride (PVC) pipeline should be installed. The effluent pipeline would be approximately 4,000 feet long.

1.1.4 Solids Dewatering and Disposal

Dried solids or “cake” would be hauled to either a landfill or composting operation. Currently, the landfill in Anderson, California is the nearest landfill that would accept these solids. There are also composting facilities in the Humboldt Bay area that could potentially accept these solids (note: a waste discharge requirement permit is required in order to accept Class B biosolids).

1.2 Phase 2 Components

Phase 2 of the proposed project would allow future infill development, consistent with existing LCP and zone, within the PCSD boundary to connect to the project’s collection system and be served by the WWTF. The increase in effluent resulting from Phase 2 implementation would be conveyed, processed, and disposed of using the facilities constructed under Phase 1. No additional construction along the collection system or at the WWTF would be required.

2.0 Report of Waste Discharge: RWQCB Form 200

An RWQCB Form 200 is included in Appendix 1 and contains general information about the applicant and the facility. A process diagram of the proposed WWTF is included as Figure 1. The approximate location of the facility is not known at this time.

3.0 General Information: EPA Form 1

An EPA Form 1 is included in Appendix 2 and contains general information about the facility, owner, and operator.

4.0 Supplemental Information: EPA Form 2D

An EPA Form 2D is included in Appendix 3 and describes new sources and new discharges of process wastewater.

5.0 Sewage Sludge Production and Disposal Information: EPA Form 2S

An EPA Form 2S containing information about biosolids treatment and disposal is included in Appendix 4. Form 2S includes Sections A through E; Sections A and B are included as a part of this application and include general facility information and biosolids production, treatment, and disposal information, respectively.

DRAFT

**RWQCB Form 200:
Report of Waste
Discharge**

1



APPLICATION/REPORT OF WASTE DISCHARGE
GENERAL INFORMATION FORM FOR
WASTE DISCHARGE REQUIREMENTS OR NPDES PERMIT



I. FACILITY INFORMATION

A. Facility:

| | | | |
|--|------------------|--------------------------------|-----------------|
| Name: Peninsula Community Services District (PCSD) Wastewater Treatment Facility | | | |
| Address: Vance Ave. | | | |
| City: Samoa | County: Humboldt | State: CA | Zip Code: 95564 |
| Contact Person: Troy Nicolini | | Telephone Number: 707-443-9042 | |

B. Facility Owner:

| | | | |
|--|-----------|--------------------------------|--|
| Name: Peninsula Community Services District (PCSD) | | | Owner Type (Check One) |
| Address: 1982 Gass Street | | | 1. <input type="checkbox"/> Individual 2. <input type="checkbox"/> Corporation |
| City: Samoa | State: CA | Zip Code: 95564 | 3. <input type="checkbox"/> Governmental Agency 4. <input type="checkbox"/> Partnership Agency |
| Contact Person: Troy Nicolini | | Telephone Number: 707-443-9042 | 5. <input checked="" type="checkbox"/> Other: Public |
| | | | Federal Tax ID: NA |

C. Facility Operator (The agency or business, not the person):

| | | | |
|------------------------------|--------|-------------------|--|
| Name: Same as Facility Owner | | | Operator Type (Check One) |
| Address: | | | 1. <input type="checkbox"/> Individual 2. <input type="checkbox"/> Corporation |
| City: | State: | Zip Code: | 3. <input type="checkbox"/> Governmental Agency 4. <input type="checkbox"/> Partnership Agency |
| Contact Person: | | Telephone Number: | 5. <input checked="" type="checkbox"/> Other: Public |

D. Owner of the Land:

| | | | |
|-----------------------------|-----------|--------------------------------|--|
| Name: Samoa Peninsula Group | | | Owner Type (Check One) |
| Address: 5251 Erickson Way | | | 1. <input type="checkbox"/> Individual 2. <input type="checkbox"/> Corporation |
| City: Arcata | State: CA | Zip Code: 95521 | 3. <input type="checkbox"/> Governmental Agency 4. <input type="checkbox"/> Partnership Agency |
| Contact Person: Dan Johnson | | Telephone Number: 707-822-9000 | 5. <input checked="" type="checkbox"/> Other: Private |

E. Address Where Legal Notice May Be Served:

| | | | |
|------------------------|---------|-------------------|-----------|
| Address: Same as Owner | | | |
| City: | County: | State: | Zip Code: |
| Contact Person: | | Telephone Number: | |

F. Billing Address:

| | | | |
|------------------------|---------|-------------------|-----------|
| Address: Same as Owner | | | |
| City: | County: | State: | Zip Code: |
| Contact Person: | | Telephone Number: | |



APPLICATION/REPORT OF WASTE DISCHARGE GENERAL INFORMATION FORM FOR WASTE DISCHARGE REQUIREMENTS OR NPDES PERMIT



II. TYPE OF DISCHARGE

Check Type of Discharge(s) Described in this Application (A or B):

[] A. WASTE DISCHARGE TO LAND

[x] B. WASTE DISCHARGE TO SURFACE WATER

Check all that apply:

- [x] Domestic/Municipal Wastewater Treatment and Disposal
[] Cooling Water
[] Mining
[] Waste Pile
[] Wastewater Reclamation
[] Other, please describe:

- [] Animal Waste Solids
[] Land Treatment Unit
[] Dredge Material Disposal
[] Surface Impoundment
[] Industrial Process Wastewater

- [] Animal or Aquacultural Wastewater
[] Biosolids/Residual
[] Hazardous Waste (see instructions)
[] Landfill (see instructions)
[] Storm Water

III. LOCATION OF THE FACILITY

Describe the physical location of the facility.

1. Assessor's Parcel Number(s)
Facility:
Discharge Point: Pacific Ocean Outfall

2. Latitude
Facility: 40.813628
Discharge Point: 40.819444

3. Longitude
Facility: -124.190142
Discharge Point: -124.225555

IV. REASON FOR FILING

- [x] New Discharge or Facility
[] Changes in Ownership/Operator (see instructions)
[] Change in Design or Operation
[] Waste Discharge Requirements Update or NPDES Permit Reissuance
[] Change in Quantity/Type of Discharge
[] Other:

V. CALIFORNIA ENVIRONMENTAL QUALITY ACT (CEQA)

Name of Lead Agency: Humboldt County Community Development Services Department
Has a public agency determined that the proposed project is exempt from CEQA? [] Yes [x] No
If Yes, state the basis for the exemption and the name of the agency supplying the exemption on the line below.
Basis for Exemption/Agency:
Has a "Notice of Determination" been filed under CEQA? [] Yes [x] No
If Yes, enclose a copy of the CEQA document, Environmental Impact Report, or Negative Declaration. If no, identify the expected type of CEQA document and expected date of completion.
Expected CEQA Documents:
[x] EIR [] Negative Declaration
Expected CEQA Completion Date: September 2019



APPLICATION/REPORT OF WASTE DISCHARGE GENERAL INFORMATION FORM FOR WASTE DISCHARGE REQUIREMENTS OR NPDES PERMIT



VI. OTHER REQUIRED INFORMATION

Please provide a COMPLETE characterization of your discharge. A complete characterization includes, but is not limited to, design and actual flows, a list of constituents and the discharge concentration of each constituent, a list of other appropriate waste discharge characteristics, a description and schematic drawing of all treatment processes, a description of any Best Management Practices (BMPs) used, and a description of disposal methods.

Also include a site map showing the location of the facility and, if you are submitting this application for an NPDES permit, identify the surface water to which you propose to discharge. Please try to limit your maps to a scale of 1:24,000 (7.5' USGS Quadrangle) or a street map, if more appropriate.

VII. OTHER

Attach additional sheets to explain any responses which need clarification. List attachments with titles and dates below:

See Attached Report

Three horizontal lines for listing attachments.

You will be notified by a representative of the RWQCB within 30 days of receipt of your application. The notice will state if your application is complete or if there is additional information you must submit to complete your Application/Report of Waste Discharge, pursuant to Division 7, Section 13260 of the California Water Code.

VIII. CERTIFICATION

"I certify under penalty of law that this document, including all attachments and supplemental information, were prepared under my direction and supervision in accordance with a system designed to assure that qualified personnel properly gathered and evaluated the information submitted. Based on my inquiry of the person or persons who manage the system, or those persons directly responsible for gathering the information, the information submitted is, to the best of my knowledge and belief, true, accurate, and complete. I am aware that there are significant penalties for submitting false information, including the possibility of fine and imprisonment."

Print Name: _____

Title: _____

Signature: _____

Date: _____

FOR OFFICE USE ONLY

Table with 4 columns: Date Form 200 Received, Letter to Discharger, Fee Amount Received, Check #.

DRAFT

**EPA Form 1: General
Information**

2

| | | | | | | | | | | | | | | |
|---|---|---|-------|--|-----|---|---|--|--|---|---|---|----|-------|
| FORM 1 GENERAL | U.S. ENVIRONMENTAL PROTECTION AGENCY GENERAL INFORMATION Consolidated Permits Program <i>(Read the "General Instructions" before starting.)</i> | I. EPA I.D. NUMBER <table border="1" style="width:100%; border-collapse: collapse;"> <tr> <td style="width:5%;">S</td> <td style="width:85%;"></td> <td style="width:5%;">T/A</td> <td style="width:5%;">C</td> </tr> <tr> <td>F</td> <td></td> <td></td> <td>D</td> </tr> <tr> <td>1</td> <td>2</td> <td>13</td> <td>14 15</td> </tr> </table> | S | | T/A | C | F | | | D | 1 | 2 | 13 | 14 15 |
| S | | T/A | C | | | | | | | | | | | |
| F | | | D | | | | | | | | | | | |
| 1 | 2 | 13 | 14 15 | | | | | | | | | | | |
| LABEL ITEMS | PLEASE PLACE LABEL IN THIS SPACE | GENERAL INSTRUCTIONS If a preprinted label has been provided, affix it in the designated space. Review the information carefully; if any of it is incorrect, cross through it and enter the correct data in the appropriate fill-in area below. Also, if any of the preprinted data is absent (<i>the area to the left of the label space lists the information that should appear</i>), please provide it in the proper fill-in area(s) below. If the label is complete and correct, you need not complete Items I, III, V, and VI (<i>except VI-B which must be completed regardless</i>). Complete all items if no label has been provided. Refer to the instructions for detailed item descriptions and for the legal authorizations under which this data is collected. | | | | | | | | | | | | |
| I. EPA I.D. NUMBER | | | | | | | | | | | | | | |
| III. FACILITY NAME | | | | | | | | | | | | | | |
| V. FACILITY MAILING ADDRESS | | | | | | | | | | | | | | |
| VI. FACILITY LOCATION | | | | | | | | | | | | | | |
| II. POLLUTANT CHARACTERISTICS | | | | | | | | | | | | | | |
| INSTRUCTIONS: Complete A through J to determine whether you need to submit any permit application forms to the EPA. If you answer "yes" to any questions, you must submit this form and the supplemental form listed in the parenthesis following the question. Mark "X" in the box in the third column if the supplemental form is attached. If you answer "no" to each question, you need not submit any of these forms. You may answer "no" if your activity is excluded from permit requirements; see Section C of the instructions. See also, Section D of the instructions for definitions of bold-faced terms . | | | | | | | | | | | | | | |
| SPECIFIC QUESTIONS | Mark "X" YES NO FORM ATTACHED | Mark "X" YES NO FORM ATTACHED | | | | | | | | | | | | |
| A. Is this facility a publicly owned treatment works which results in a discharge to waters of the U.S.? (FORM 2A) | <input type="checkbox"/> YES <input checked="" type="checkbox"/> NO <input type="checkbox"/> FORM ATTACHED | B. Does or will this facility (<i>either existing or proposed</i>) include a concentrated animal feeding operation or aquatic animal production facility which results in a discharge to waters of the U.S.? (FORM 2B) | | | | | | | | | | | | |
| C. Is this a facility which currently results in discharges to waters of the U.S. other than those described in A or B above? (FORM 2C) | <input type="checkbox"/> YES <input checked="" type="checkbox"/> NO <input type="checkbox"/> FORM ATTACHED | D. Is this a proposed facility (<i>other than those described in A or B above</i>) which will result in a discharge to waters of the U.S.? (FORM 2D) | | | | | | | | | | | | |
| E. Does or will this facility treat, store, or dispose of hazardous wastes? (FORM 3) | <input type="checkbox"/> YES <input checked="" type="checkbox"/> NO <input type="checkbox"/> FORM ATTACHED | F. Do you or will you inject at this facility industrial or municipal effluent below the lowermost stratum containing, within one quarter mile of the well bore, underground sources of drinking water? (FORM 4) | | | | | | | | | | | | |
| G. Do you or will you inject at this facility any produced water or other fluids which are brought to the surface in connection with conventional oil or natural gas production, inject fluids used for enhanced recovery of oil or natural gas, or inject fluids for storage of liquid hydrocarbons? (FORM 4) | <input type="checkbox"/> YES <input checked="" type="checkbox"/> NO <input type="checkbox"/> FORM ATTACHED | H. Do you or will you inject at this facility fluids for special processes such as mining of sulfur by the Frasch process, solution mining of minerals, in situ combustion of fossil fuel, or recovery of geothermal energy? (FORM 4) | | | | | | | | | | | | |
| I. Is this facility a proposed stationary source which is one of the 28 industrial categories listed in the instructions and which will potentially emit 100 tons per year of any air pollutant regulated under the Clean Air Act and may affect or be located in an attainment area? (FORM 5) | <input type="checkbox"/> YES <input checked="" type="checkbox"/> NO <input type="checkbox"/> FORM ATTACHED | J. Is this facility a proposed stationary source which is NOT one of the 28 industrial categories listed in the instructions and which will potentially emit 250 tons per year of any air pollutant regulated under the Clean Air Act and may affect or be located in an attainment area? (FORM 5) | | | | | | | | | | | | |
| III. NAME OF FACILITY | | | | | | | | | | | | | | |
| c | SKIP | Samoa Peninsula Wastewater Treatment Facility | | | | | | | | | | | | |
| 15 | 16 - 29 | 30 | | | | | | | | | | | | |
| IV. FACILITY CONTACT | | | | | | | | | | | | | | |
| A. NAME & TITLE (<i>last, first, & title</i>) | | B. PHONE (<i>area code & no.</i>) | | | | | | | | | | | | |
| c | Nicolini, Troy, President | (707) 443-9042 | | | | | | | | | | | | |
| 15 | 16 | 45 46 48 49 51 52 55 | | | | | | | | | | | | |
| V. FACILITY MAILING ADDRESS | | | | | | | | | | | | | | |
| A. STREET OR P.O. BOX | | | | | | | | | | | | | | |
| c | 1982 Gass Street | | | | | | | | | | | | | |
| 15 | 16 | | | | | | | | | | | | | |
| B. CITY OR TOWN | | C. STATE | | | | | | | | | | | | |
| c | Samoa | CA | | | | | | | | | | | | |
| 15 | 16 | 40 41 42 | | | | | | | | | | | | |
| D. ZIP CODE | | E. ZIP CODE | | | | | | | | | | | | |
| | | 95564 | | | | | | | | | | | | |
| | | 47 51 | | | | | | | | | | | | |
| VI. FACILITY LOCATION | | | | | | | | | | | | | | |
| A. STREET, ROUTE NO. OR OTHER SPECIFIC IDENTIFIER | | | | | | | | | | | | | | |
| c | Vance Ave | | | | | | | | | | | | | |
| 15 | 16 | | | | | | | | | | | | | |
| B. COUNTY NAME | | | | | | | | | | | | | | |
| Humboldt | | | | | | | | | | | | | | |
| 46 | 70 | | | | | | | | | | | | | |
| C. CITY OR TOWN | | D. STATE | | | | | | | | | | | | |
| c | Samoa | CA | | | | | | | | | | | | |
| 15 | 16 | 40 41 42 | | | | | | | | | | | | |
| E. ZIP CODE | | F. COUNTY CODE (<i>if known</i>) | | | | | | | | | | | | |
| 95564 | | 023 | | | | | | | | | | | | |
| | | 51 52 -54 | | | | | | | | | | | | |

CONTINUED FROM THE FRONT

| VII. SIC CODES (4-digit, in order of priority) | | | |
|--|----|--------------------------|-----------|
| A. FIRST | | B. SECOND | |
| C | 7 | (specify) Sewage Systems | (specify) |
| 15 | 16 | 18 | 19 |
| C. THIRD | | D. FOURTH | |
| C | 7 | (specify) | (specify) |
| 15 | 16 | 18 | 19 |

| VIII. OPERATOR INFORMATION | | | |
|--|--|----|---|
| A. NAME | | | B. Is the name listed in Item VIII-A also the owner? |
| C | 8 Peninsula Community Services District | | <input checked="" type="checkbox"/> YES <input type="checkbox"/> NO |
| 15 | 16 | 55 | 66 |
| C. STATUS OF OPERATOR (Enter the appropriate letter into the answer box: if "Other," specify.) | | | D. PHONE (area code & no.) |
| F = FEDERAL | M = PUBLIC (other than federal or state) | M | (specify) |
| S = STATE | O = OTHER (specify) | 56 | |
| P = PRIVATE | | | |
| | | | A (707) 443-9042 |
| 15 | 16 | 18 | 19 21 22 26 |

| | |
|-----------------------|----|
| E. STREET OR P.O. BOX | |
| 1982 Gass Street | |
| 26 | 55 |

| | | | | |
|-----------------|---------|----------|-------------|---|
| F. CITY OR TOWN | | G. STATE | H. ZIP CODE | IX. INDIAN LAND |
| C | B Samoa | CA | 95564 | Is the facility located on Indian lands? |
| 15 | 16 | 40 41 | 42 47 51 | <input type="checkbox"/> YES <input checked="" type="checkbox"/> NO |
| | | | | 52 |

| X. EXISTING ENVIRONMENTAL PERMITS | | | |
|--|----|--|-----------|
| A. NPDES (Discharges to Surface Water) | | D. PSD (Air Emissions from Proposed Sources) | |
| C | T | I | (specify) |
| 9 | N | NA | |
| 15 | 16 | 17 | 18 30 |
| B. UIC (Underground Injection of Fluids) | | E. OTHER (specify) | |
| C | T | I | (specify) |
| 9 | U | | |
| 15 | 16 | 17 | 18 30 |
| C. RCRA (Hazardous Wastes) | | E. OTHER (specify) | |
| C | T | I | (specify) |
| 9 | R | | |
| 15 | 16 | 17 | 18 30 |

XI. MAP
 Attach to this application a topographic map of the area extending to at least one mile beyond property boundaries. The map must show the outline of the facility, the location of each of its existing and proposed intake and discharge structures, each of its hazardous waste treatment, storage, or disposal facilities, and each well where it injects fluids underground. Include all springs, rivers, and other surface water bodies in the map area. See instructions for precise requirements.

XII. NATURE OF BUSINESS (provide a brief description)
 Collection, treatment and disposal system for residential, commercial/industrial, recreational and institutional facilities located within the boundaries of the Peninsula Community Services District.

XIII. CERTIFICATION (see instructions)
 I certify under penalty of law that I have personally examined and am familiar with the information submitted in this application and all attachments and that, based on my inquiry of those persons immediately responsible for obtaining the information contained in the application, I believe that the information is true, accurate, and complete. I am aware that there are significant penalties for submitting false information, including the possibility of fine and imprisonment.

| | | |
|--|--------------|----------------|
| A. NAME & OFFICIAL TITLE (type or print) | B. SIGNATURE | C. DATE SIGNED |
|--|--------------|----------------|

| COMMENTS FOR OFFICIAL USE ONLY | |
|--------------------------------|-------|
| C | |
| 15 | 16 55 |

DRAFT

**EPA Form 2D:
Supplemental
Information**

3

B. Attach a line drawing showing the water flow through the facility. Indicate sources of intake water, operations contributing wastewater to the effluent, and treatment units labeled to correspond to the more detailed descriptions in Item III-A. Construct a water balance on the line drawing by showing average flows between intakes, operations, treatment units, and outfalls. If a water balance cannot be determined (e.g., for certain mining activities), provide a pictorial description of the nature and amount of any sources of water and any collection or treatment measures.

C. Except for storm runoff, leaks, or spills, will any of the discharges described in Items III-A be intermittent or seasonal?

YES (complete the following table)

NO (go to Section IV)

| Outfall Number | 1. Frequency | | 2. Flow | | |
|----------------|---------------------------------------|---|--|---|--------------------------|
| | a. Days Per Week (specify average) | b. Months Per Year (specify average) | a. Maximum Daily Flow Rate (in mgd) | b. Maximum Total Volume (specify with units) | c. Duration (in days) |
| | | | | | |

DRAFT

IV. Production

If there is an applicable production-based effluent guideline or NSPS, for each outfall list the estimated level of production (projection of actual production level, not design), expressed in the terms and units used in the applicable effluent guideline or NSPS, for each of the first 3 years of operation. If production is likely to vary, you may also submit alternative estimates (attach a separate sheet).

| Year | A. Quantity Per Day | B. Units Of Measure | c. Operation, Product, Material, etc. (specify) |
|------|---------------------|---------------------|---|
| | | | |
| | | | |
| | | | |

C. Use the space below to list any of the pollutants listed in Table 2D-3 of the instructions which you know or have reason to believe will be discharged from any outfall. For every pollutant you list, briefly describe the reasons you believe it will be present.

| 1. Pollutant | 2. Reason for Discharge |
|--------------|-------------------------|
| None. | |

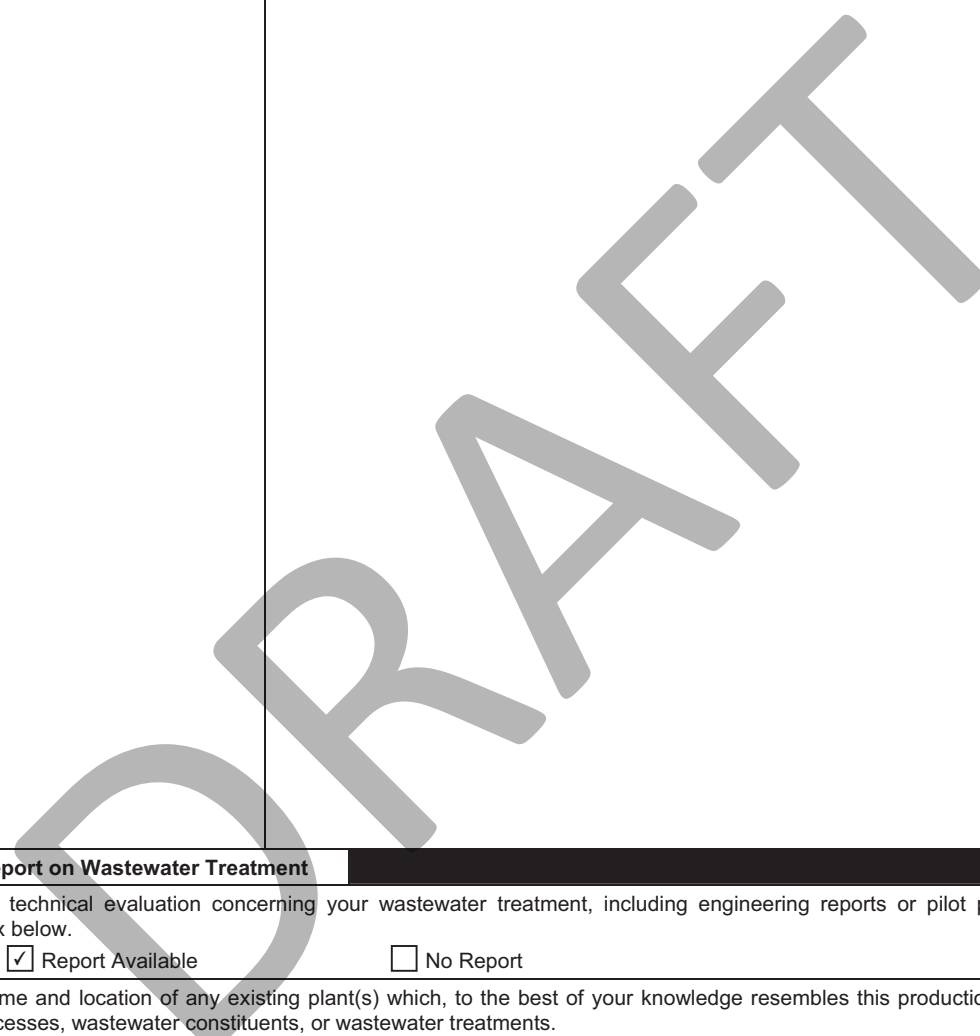

VI. Engineering Report on Wastewater Treatment

A. If there is any technical evaluation concerning your wastewater treatment, including engineering reports or pilot plant studies, check the appropriate box below.
 Report Available No Report

B. Provide the name and location of any existing plant(s) which, to the best of your knowledge resembles this production facility with respect to production processes, wastewater constituents, or wastewater treatments.

| Name | Location |
|------|----------|
| | |

VII. Other Information (Optional)

Use the space below to expand upon any of the above questions or to bring to the attention of the reviewer any other information you feel should be considered in establishing permit limitations for the proposed facility. Attach additional sheets if necessary.

See Attached Report

DRAFT

VIII. CERTIFICATION

I certify under penalty of law that this document and all attachments were prepared under my direction or supervision in accordance with a system designed to assure that qualified personnel properly gather and evaluate the information submitted. Based on my inquiry of the person or persons who manage the system, or those persons directly responsible for gathering the information, the information submitted is, to the best of my knowledge and belief, true, accurate, and complete. I am aware that there are significant penalties for submitting false information, including the possibility of fine and imprisonment for knowing violations.

A. Name and Official Title (type or print)

B. Phone No.

C. Signature

D. Date Signed

DRAFT

**EPA Form 2S: Sewage
Sludge Production &
Disposal Information**

4

FACILITY NAME AND PERMIT NUMBER:

Peninsula Community Services District WWTF

Form Approved 1/14/99
OMB Number 2040-0086

FORM
2S
NPDES

NPDES FORM 2S APPLICATION OVERVIEW

PRELIMINARY INFORMATION

This page is designed to indicate whether the applicant is to complete Part 1 or Part 2. Review each category, and then complete Part 1 or Part 2, as indicated. For purposes of this form, the term "you" refers to the applicant. "This facility" and "your facility" refer to the facility for which application information is submitted.

FACILITIES INCLUDED IN ANY OF THE FOLLOWING CATEGORIES MUST COMPLETE PART 2 (PERMIT APPLICATION INFORMATION).

1. Facilities with a currently effective NPDES permit.
2. Facilities which have been directed by the permitting authority to submit a full permit application at this time.

ALL OTHER FACILITIES MUST COMPLETE PART 1 (LIMITED BACKGROUND INFORMATION).

DRAFT

FACILITY NAME AND PERMIT NUMBER:
Peninsula Community Services District WWTF

Form Approved 1/14/99
OMB Number 2040-0086

PART 1: LIMITED BACKGROUND INFORMATION

This part should be completed only by "sludge-only" facilities - that is, facilities that do not currently have, and are not applying for, an NPDES permit for a direct discharge to a surface body of water.

For purposes of this form, the term "you" refers to the applicant. "This facility" and "your facility" refer to the facility for which application information is submitted.

1. Facility Information.

- a. Facility name Peninsula Community Services District
- b. Mailing Address 1982 Gass Street, Samoa 95564
- c. Contact person Troy Nicolini
Title President
Telephone number (707) 443-9042
- d. Facility Address (not P.O. B ox) Vance Avenue, Samoa, CA 95564
- e. Indicate the type of facility
 Publicly owned treatment works (POTW) Privately owned treatment works
 Federally owned treatment works Blending or treatment operation
 Surface disposal site Sewage sludge incinerator
 Other (describe) _____

2. Applicant Information.

- a. Applicant name Peninsula Community Services District
- b. Mailing Address 1982 Gass Street, Samoa 95564
- c. Contact person Troy Nicolini
Title President
Telephone number (707) 443-9042
- d. Is the applicant the owner or operator (or both) of this facility?
 owner operator
- e. Should correspondence regarding this permit be directed to the facility or the applicant?
 facility applicant

FACILITY NAME AND PERMIT NUMBER:
 Peninsula Community Services District WWTF

Form Approved 1/14/99
 OMB Number 2040-0086

3. Sewage Sludge Amount. Provide the total dry metric tons per latest 365 day period of sewage sludge handled under the following practices:

- a. Amount generated at the facility 353.00 dry metric tons
 - b. Amount received from off site _____ dry metric tons
 - c. Amount treated or blended on site 353.00 dry metric tons
 - d. Amount sold or given away in a bag or other container for application to the land _____ dry metric tons
 - e. Amount of bulk sewage sludge shipped off site for treatment or blending _____ dry metric tons
 - f. Amount applied to the land in bulk form _____ dry metric tons
 - g. Amount placed on a surface disposal site _____ dry metric tons
 - h. Amount fired in a sewage sludge incinerator _____ dry metric tons
 - i. Amount sent to a municipal solid waste landfill 353.00 dry metric tons
 - j. Amount used or disposed by another practice _____ dry metric tons
- Describe _____

4. Pollutant Concentrations. Using the table below or a separate attachment, provide existing sewage sludge monitoring data for the pollutants for which limits in sewage sludge have been established in 40 CFR part 503 for this facility's expected use or disposal practices. If available, base data on three or more samples taken at least one month apart and no more than four and one-half years old.

| POLLUTANT | CONCENTRATION (mg/kg dry weight) | ANALYTICAL METHOD | DETECTION LEVEL FOR ANALYSIS |
|------------|----------------------------------|-------------------|------------------------------|
| ARSENIC | | | |
| CADMIUM | | | |
| CHROMIUM | | | |
| COPPER | | | |
| LEAD | | | |
| MERCURY | | | |
| MOLYBDENUM | | | |
| NICKEL | | | |
| SELENIUM | | | |
| ZINC | | | |

5. Treatment Provided At Your Facility.

- a. Which class of pathogen reduction does the sewage sludge meet at your facility?
 _____ Class A Class B _____ Neither or unknown
- b. Describe, on this form or another sheet of paper, any treatment processes used at your facility to reduce pathogens in sewage sludge:
Polymer addition, dewatering, and gravity thickening

FACILITY NAME AND PERMIT NUMBER:

Peninsula Community Services District WWTF

Form Approved 1/14/99
OMB Number 2040-0086

c. Which vector attraction reduction option is met for the sewage sludge at your facility?

- Option 1 (Minimum 38 percent reduction in volatile solids)
- Option 2 (Anaerobic process, with bench-scale demonstration)
- Option 3 (Aerobic process, with bench-scale demonstration)
- Option 4 (Specific oxygen uptake rate for aerobically digested sludge)
- Option 5 (Aerobic processes plus raised temperature)
- Option 6 (Raise pH to 12 and retain at 11.5)
- Option 7 (75 percent solids with no unstabilized solids)
- Option 8 (90 percent solids with unstabilized solids)
- Option 9 (Injection below land surface)
- Option 10 (Incorporation into soil within 6 hours)
- Option 11 (Covering active sewage sludge unit daily)
- None or unknown

d. Describe, on this form or another sheet of paper, any treatment processes used at your facility to reduce vector attraction properties of sewage sludge:

Polymer addition, dewatering, and gravity thickening

6. **Sewage Sludge Sent to Other Facilities.** Does the sewage sludge from your facility meet the Table 1 ceiling concentrations, the Table 3 pollutant concentrations, Class A pathogen requirements, and one of the vector attraction options 1-8?

Yes No

If yes, go to question 8 (Certification).

If no, is sewage sludge from your facility provided to another facility for treatment, distribution, use, or disposal?

Yes No

If no, go to question 7 (Use and Disposal Sites).

If yes, provide the following information for the facility receiving the sewage sludge:

- a. Facility name Anderson Landfill
- b. Mailing address 18703 Cambridge Road
Anderson, CA 96007
- c. Contact person David Bayley
Title District Manager
Telephone number (530) 227-8730

d. Which activities does the receiving facility provide? (Check all that apply)

- Treatment or blending
- Land application
- Incineration
- Sale or give-away in bag or other container
- Surface disposal
- Other (describe):

Municipal Solid Waste Landfill

FACILITY NAME AND PERMIT NUMBER:

Peninsula Community Services District WWTF

Form Approved 1/14/99
OMB Number 2040-0086

7. Use and Disposal Sites. Provide the following information for each site on which sewage sludge from this facility is used or disposed:

- a. Site name or number Same as above.
- b. Contact person _____
Title _____
Telephone _____
- c. Site location (Complete 1 or 2)
 - 1. Street or Route # _____
County _____
City or Town _____ State _____ Zip _____
 - 2. Latitude _____ Longitude _____
- d. Site type (Check all that apply)
 - Agricultural
 - Surface disposal
 - Reclamation
 - Lawn or home garden
 - Public Contact
 - Municipal Solid Waste Landfill
 - Forest
 - Incineration
 - Other (describe): _____

8. Certification. Sign the certification statement below. (Refer to instructions to determine who is an officer for purposes of this certification.)

I certify under penalty of law that this document and all attachments were prepared under my direction or supervision in accordance with the system designed to assure that qualified personnel properly gather and evaluate the information submitted. Based on my inquiry of the person or persons who manage the system or those persons directly responsible for gathering the information, the information is, to the best of my knowledge and belief, true, accurate, and complete. I am aware that there are significant penalties for submitting false information, including the possibility of fine and imprisonment for knowing violations.

Name and official title _____
Signature _____
Telephone number _____
Date signed _____

SEND COMPLETED FORMS TO:

FACILITY NAME AND PERMIT NUMBER:

Peninsula Community Services District WWTF

Form Approved 1/14/99
OMB Number 2040-0086

PART 2: PERMIT APPLICATION INFORMATION

Complete this part if you have an effective NPDES permit or have been directed by the permitting authority to submit a full permit application at this time. In other words, complete this part if your facility has, or is applying for, an NPDES permit.

For purposes of this form, the term “you” refers to the applicant. “This facility” and “your facility” refer to the facility for which application information is submitted.

APPLICATION OVERVIEW — SEWAGE SLUDGE USE OR DISPOSAL INFORMATION

Part 2 is divided into five sections (A-E). Section A pertains to all applicants. The applicability of Sections B, C, D, and E depends on your facility's sewage sludge use or disposal practices. The information provided on this page indicates which sections of Part 2 to fill out.

1. SECTION A: GENERAL INFORMATION.

Section A must be completed by all applicants

2. SECTION B: GENERATION OF SEWAGE SLUDGE OR PREPARATION OF A MATERIAL DERIVED FROM SEWAGE SLUDGE.

Section B must be completed by applicants who either:

- 1) Generate sewage sludge, or
- 2) Derive a material from sewage sludge.

3. SECTION C: LAND APPLICATION OF BULK SEWAGE SLUDGE.

Section C must be completed by applicants who either:

- 1) Apply sewage to the land, or
- 2) Generate sewage sludge which is applied to the land by others.

NOTE: Applicants who meet either or both of the two above criteria are exempted from this requirement if all sewage sludge from their facility falls into one of the following three categories:

- 1) The sewage sludge from this facility meets the ceiling and pollutant concentrations, Class A pathogen reduction requirements, and one of vector attraction reduction options 1-8, as identified in the instructions, or
- 2) The sewage sludge from this facility is placed in a bag or other container for sale or give-away for application to the land, or
- 3) The sewage sludge from this facility is sent to another facility for treatment or blending.

4. SECTION D: SURFACE DISPOSAL

Section D must be completed by applicants who own or operate a surface disposal site.

5. SECTION E: INCINERATION

Section E must be completed by applicants who own or operate a sewage sludge incinerator.

FACILITY NAME AND PERMIT NUMBER:

Peninsula Community Services District WWTF

Form Approved 1/14/99
OMB Number 2040-0086

A. GENERAL INFORMATION

All applicants must complete this section.

A.1. Facility Information.

- a. Facility name Peninsula Community Services District WWTF
- b. Mailing Address 1982 Gass Street, Samoa 95564
- c. Contact person Troy Nicolini
Title President
Telephone number (707) 443-9042
- d. Facility Address (not P.O. Box) Vance Avenue, Samoa, CA 95564
- e. Is this facility a Class I sludge management facility? Yes No
- f. Facility design flow rate: 0.06 mgd
- g. Total population served: 215.00
- h. Indicate the type of facility:
 Publicly owned treatment works (POTW) Privately owned treatment works
 Federally owned treatment works Blending or treatment operation
 Surface disposal site Sewage sludge incinerator
 Other (describe) _____

A.2. Applicant Information. If the applicant is different from the above, provide the following:

- a. Applicant name Peninsula Community Services District
- b. Mailing Address 1982 Gass Street, Samoa 95564
- c. Contact person Troy Nicolini
Title President
Telephone number (707) 443-9042
- d. Is the applicant the owner or operator (or both) of this facility?
 owner operator
- e. Should correspondence regarding this permit should be directed to the facility or the applicant.
 facility applicant

FACILITY NAME AND PERMIT NUMBER:

Peninsula Community Services District WWTF

Form Approved 1/14/99
OMB Number 2040-0086

A.3. Permit Information.

- a. Facility's NPDES permit number (if applicable): NA
- b. List, on this form or an attachment, all other Federal, State, and local permits or construction approvals received or applied for that regulate this facility's sewage sludge management practices:

| Permit Number | Type of Permit |
|---------------|----------------|
| _____ | _____ |
| _____ | _____ |
| _____ | _____ |

A.4. Indian Country. Does any generation, treatment, storage, application to land, or disposal of sewage sludge from this facility occur in Indian Country?

_____ Yes No If yes, describe: _____

A.5. Topographic Map. Provide a topographic map or maps (or other appropriate map(s) if a topographic map is unavailable) that show the following information. Map(s) should include the area one mile beyond all property boundaries of the facility:

- a. Location of all sewage sludge management facilities, including locations where sewage sludge is stored, treated, or disposed.
- b. Location of all wells, springs, and other surface water bodies, listed in public records or otherwise known to the applicant within 1/4 mile of the facility property boundaries.

A.6. Line Drawing. Provide a line drawing and/or a narrative description that identifies all sewage sludge processes that will be employed during the term of the permit, including all processes used for collecting, dewatering, storing, or treating sewage sludge, the destination(s) of all liquids and solids leaving each unit, and all methods used for pathogen reduction and vector attraction reduction.

A.7. Contractor Information.

Are any operational or maintenance aspects of this facility related to sewage sludge generation, treatment, use or disposal the responsibility of a contractor? _____ Yes No

If yes, provide the following for each contractor (attach additional pages if necessary):

- a. Name _____
- b. Mailing Address _____
- c. Telephone Number _____
- d. Responsibilities of contractor _____

FACILITY NAME AND PERMIT NUMBER:

Peninsula Community Services District WWTF

Form Approved 1/14/99
OMB Number 2040-0086

A.8. Pollution Concentrations: Using the table below or a separate attachment, provide sewage sludge monitoring data for the pollutants for which limits in sewage sludge have been established in 40 CFR Part 503 for this facility's expected use or disposal practices. All data must be based on three or more samples taken at least one month apart and must be no more than four and one-half years old.

| POLLUTANT | CONCENTRATION (mg/kg dry weight) | ANALYTICAL METHOD | DETECTION LEVEL FOR ANALYSIS |
|------------|-------------------------------------|-------------------|------------------------------|
| ARSENIC | Not Available | | |
| CADMIUM | Not Available | | |
| CHROMIUM | Not Available | | |
| COPPER | Not Available | | |
| LEAD | Not Available | | |
| MERCURY | Not Available | | |
| MOLYBDENUM | Not Available | | |
| NICKEL | Not Available | | |
| SELENIUM | Not Available | | |
| ZINC | Not Available | | |

A.9. Certification. Read and submit the following certification statement with this application. Refer to the instructions to determine who is an officer for purposes of this certification. Indicate which parts of Form 2S you have completed and are submitting:

Part 1 Limited Background Information packet

Part 2 Permit Application Information packet:

- Section A (General Information)
 Section B (Generation of Sewage Sludge or Preparation of a Material Derived from Sewage Sludge)
 Section C (Land Application of Bulk Sewage Sludge)
 Section D (Surface Disposal)
 Section E (Incineration)

I certify under penalty of law that this document and all attachments were prepared under my direction or supervision in accordance with the system designed to assure that qualified personnel properly gather and evaluate the information submitted. Based on my inquiry of the person or persons who manage the system or those persons directly responsible for gathering the information, the information is, to the best of my knowledge and belief, true, accurate, and complete. I am aware that there are significant penalties for submitting false information, including the possibility of fine and imprisonment for knowing violations.

Name and official title _____

Signature _____ Date signed _____

Telephone number _____

Upon request of the permitting authority, you must submit any other information necessary to assess sewage sludge use or disposal practices at your facility or identify appropriate permitting requirements.

SEND COMPLETED FORMS TO:

B. GENERATION OF SEWAGE SLUDGE OR PREPARATION OF A MATERIAL DERIVED FROM SEWAGE SLUDGE

Complete this section if your facility generates sewage sludge or derives a material from sewage sludge.

B.1. Amount Generated On Site.

Total dry metric tons per 365-day period generated at your facility: 353.00 dry metric tons

B.2. Amount Received from Off Site. If your facility receives sewage sludge from another facility for treatment, use, or disposal, provide the following information for each facility from which sewage sludge is received. If you receive sewage sludge from more than one facility, attach additional pages as necessary.

- a. Facility name NA
- b. Mailing Address _____
- c. Contact person _____
Title _____
Telephone number _____
- d. Facility Address (not P.O. Box) _____
- e. Total dry metric tons per 365-day period received from this facility: _____ dry metric tons
- f. Describe, on this form or on another sheet of paper, any treatment processes known to occur at the off-site facility, including blending activities and treatment to reduce pathogens or vector attraction characteristics.

B.3. Treatment Provided At Your Facility.

- a. Which class of pathogen reduction is achieved for the sewage sludge at your facility?
 Class A Class B Neither or unknown
- b. Describe, on this form or another sheet of paper, any treatment processes used at your facility to reduce pathogens in sewage sludge:
Polymer addition, dewatering, and gravity thickening

- c. Which vector attraction reduction option is met for the sewage sludge at your facility?
 Option 1 (Minimum 38 percent reduction in volatile solids)
 Option 2 (Anaerobic process, with bench-scale demonstration)
 Option 3 (Aerobic process, with bench-scale demonstration)
 Option 4 (Specific oxygen uptake rate for aerobically digested sludge)
 Option 5 (Aerobic processes plus raised temperature)
 Option 6 (Raise pH to 12 and retain at 11.5)
 Option 7 (75 percent solids with no unstabilized solids)
 Option 8 (90 percent solids with unstabilized solids)
 None or unknown

FACILITY NAME AND PERMIT NUMBER:

Peninsula Community Services District WWTF

Form Approved 1/14/99
OMB Number 2040-0086

B.3. Treatment Provided At Your Facility. (con't)

d. Describe, on this form or another sheet of paper, any treatment processes used at your facility to reduce vector attraction properties of sewage sludge:

Polymer addition, dewatering, and gravity thickening

e. Describe, on this form or another sheet of paper, any other sewage sludge treatment or blending activities not identified in (a) - (d) above:

Complete Section B.4 if sewage sludge from your facility meets the ceiling concentrations in Table 1 of 40 CFR 503.13, the pollutant concentrations in Table 3 of §503.13, the Class A pathogen reduction requirements in §503.32(a), and one of the vector attraction reduction requirements in § 503.33(b)(1)-(8) and is land applied. Skip this section if sewage sludge from your facility does not meet all of these criteria.

B.4. Preparation of Sewage Sludge Meeting Ceiling and Pollutant Concentrations, Class A Pathogen Requirements, and One of Vector Attraction Reduction Options 1-8.

a. Total dry metric tons per 365-day period of sewage sludge subject to this section that is applied to the land: _____ dry metric tons

b. Is sewage sludge subject to this section placed in bags or other containers for sale or give-away for application to the land?

_____ Yes _____ No

Complete Section B.5. if you place sewage sludge in a bag or other container for sale or give-away for land application. Skip this section if the sewage sludge is covered in Section B.4.

B.5. Sale or Give-Away in a Bag or Other Container for Application to the Land.

a. Total dry metric tons per 365-day period of sewage sludge placed in a bag or other container at your facility for sale or give-away for application to the land: _____ dry metric tons

b. Attach, with this application, a copy of all labels or notices that accompany the sewage sludge being sold or given away in a bag or other container for application to the land.

Complete Section B.6 if sewage sludge from your facility is provided to another facility that provides treatment or blending. This section does not apply to sewage sludge sent directly to a land application or surface disposal site. Skip this section if the sewage sludge is covered in Sections B.4 or B.5. If you provide sewage sludge to more than one facility, attach additional pages as necessary.

B.6. Shipment Off Site for Treatment or Blending.

a. Receiving facility name _____

b. Mailing address _____

c. Contact person _____

Title _____

Telephone number _____

d. Total dry metric tons per 365-day period of sewage sludge provided to receiving facility: _____

FACILITY NAME AND PERMIT NUMBER:

Peninsula Community Services District WWTF

Form Approved 1/14/99
OMB Number 2040-0086

B.6. Shipment Off Site for Treatment or Blending. (con't)

e. Does the receiving facility provide additional treatment to reduce pathogens in sewage sludge from your facility? Yes No

Which class of pathogen reduction is achieved for the sewage sludge at the receiving facility?

Class A Class B Neither or unknown

Describe, on this form or another sheet of paper, any treatment processes used at the receiving facility to reduce pathogens in sewage sludge:

f. Does the receiving facility provide additional treatment to reduce vector attraction characteristics of the sewage sludge?

Yes No

Which vector attraction reduction option is met for the sewage sludge at the receiving facility?

- Option 1 (Minimum 38 percent reduction in volatile solids)
- Option 2 (Anaerobic process, with bench-scale demonstration)
- Option 3 (Aerobic process, with bench-scale demonstration)
- Option 4 (Specific oxygen uptake rate for aerobically digested sludge)
- Option 5 (Aerobic processes plus raised temperature)
- Option 6 (Raise pH to 12 and retain at 11.5)
- Option 7 (75 percent solids with no unstabilized solids)
- Option 8 (90 percent solids with unstabilized solids)
- None

Describe, on this form or another sheet of paper, any treatment processes used at the receiving facility to reduce vector attraction properties of sewage sludge.

g. Does the receiving facility provide any additional treatment or blending activities not identified in (c) or (d) above? Yes No

If yes, describe, on this form or another sheet of paper, the treatment or blending activities not identified in (c) or (d) above:

h. If you answered yes to (e), (f), or (g), attach a copy of any information you provide the receiving facility to comply with the "notice and necessary information" requirement of 40 CFR 503.12(g).

i. Does the receiving facility place sewage sludge from your facility in a bag or other container for sale or give-away for application to the land? Yes No

If yes, provide a copy of all labels or notices that accompany the product being sold or given away.

Complete Section B.7 if sewage sludge from your facility is applied to the land, unless the sewage sludge is covered in:

- Section B.4 (it meets Table 1 ceiling concentrations, Table 3 pollutant concentrations, Class A pathogen requirements, and one of vector attraction reduction options 1-8); or
- Section B.5 (you place it in a bag or other container for sale or give-away for application to the land); or
- Section B.6 (you send it to another facility for treatment or blending).

B.7. Land Application of Bulk Sewage Sludge.

a. Total dry metric tons per 365-day period of sewage sludge applied to all land application sites: _____ dry metric tons

FACILITY NAME AND PERMIT NUMBER:

Peninsula Community Services District WWTF

Form Approved 1/14/99
OMB Number 2040-0086

B.7. Land Application of Bulk Sewage Sludge. (con't)

b. Do you identify all land application sites in Section C of this application? Yes No

If no, submit a copy of the land application plan with application (see instructions).

c. Are any land application sites located in States other than the State where you generate sewage sludge or derive a material from sewage sludge? Yes No

If yes, describe, on this form or another sheet of paper, how you notify the permitting authority for the States where the land application sites are located. Provide a copy of the notification.

Complete Section B.8 if sewage sludge from your facility is placed on a surface disposal site.

B.8. Surface Disposal.

a. Total dry metric tons of sewage sludge from your facility placed on all surface disposal sites per 365-day period: _____ dry metric tons

b. Do you own or operate all surface disposal sites to which you send sewage sludge for disposal?

Yes No

If no, answer B.8.c through B.8.f for each surface disposal site that you do not own or operate. If you send sewage sludge to more than one such surface disposal site, attach additional pages as necessary.

c. Site name or number _____

d. Contact person _____

Title _____

Telephone number _____

Contact is Site owner Site operator

e. Mailing address _____

f. Total dry metric tons of sewage sludge from your facility placed on this surface disposal site per 365-day period: _____ dry metric tons

Complete Section B.9 if sewage sludge from your facility is fired in a sewage sludge incinerator.

B.9. Incineration.

a. Total dry metric tons of sewage sludge from your facility fired in all sewage sludge incinerators per 365-day period: _____ dry metric tons

b. Do you own or operate all sewage sludge incinerators in which sewage sludge from your facility is fired? Yes No

If no, complete B.9.c through B.9.f for each sewage sludge incinerator that you do not own or operate. If you send sewage sludge to more than one such sewage sludge incinerator, attach additional pages as necessary.

c. Incinerator name or number: _____

d. Contact person: _____

Title: _____

Telephone number: _____

Contact is: Incinerator owner Incinerator operator

FACILITY NAME AND PERMIT NUMBER:

Peninsula Community Services District WWTF

Form Approved 1/14/99
OMB Number 2040-0086

B.9. Incineration. (con't)

e. Mailing address: _____

f. Total dry metric tons of sewage sludge from your facility fired in this sewage sludge incinerator per 365-day period: _____ dry metric tons

Complete Section B.10 if sewage sludge from this facility is placed on a municipal solid waste landfill.

B.10. Disposal in a Municipal Solid Waste Landfill. Provide the following information for each municipal solid waste landfill on which sewage sludge from your facility is placed. If sewage sludge is placed on more than one municipal solid waste landfill, attach additional pages as necessary.

a. Name of landfill Waste Management - Anderson Landfill

b. Contact person David Bayley
 Title District Manager
 Telephone number (530) 227-8730

Contact is Landfill owner Landfill operator

c. Mailing address 18703 Cambridge Road, Anderson 96007

d. Location of municipal solid waste landfill:
 Street or Route # 18703 Cambridge Road
 County Shasta
 City or Town Anderson State CA Zip 96007

e. Total dry metric tons of sewage sludge from your facility placed in this municipal solid waste landfill per 365-day period:
353.00 dry metric tons

f. List, on this form or an attachment, the numbers of all other Federal, State, and local permits that regulate the operation of this municipal solid waste landfill.

| Permit Number | Type of Permit |
|-------------------|---------------------------|
| <u>45-AA-0020</u> | <u>Solid Waste Permit</u> |
| _____ | _____ |
| _____ | _____ |

g. Submit, with this application, information to determine whether the sewage sludge meets applicable requirements for disposal of sewage sludge in a municipal solid waste landfill (e.g., results of paint filter liquids test and TCLP test)

h. Does the municipal solid waste landfill comply with applicable criteria set forth in 40 CFR Part 258?
 Yes No

DRAFT

**Preliminary Design
Report**

5



Samoa Peninsula Wastewater Project

Planning and Design Study

County of Humboldt Planning and Building Department

GHD | 718 Third Street, Eureka, CA 95501

SHN | 812 W Wabash Avenue, Eureka, CA 95501

March 2018



SH
Engineers & Geologists

DRAFT

Executive Summary

This Preliminary Engineering Report (PER) has been completed for the County of Humboldt to evaluate the future of wastewater on the Samoa Peninsula. The purpose of this PER is to assess the feasibility of a consolidated wastewater collection, treatment, and disposal system for residential, commercial/industrial, recreational, and institutional facilities located within the boundaries of the proposed Peninsula Community Services District (PCSD) (see Figure 1-1 and Figure 1-2). This Report reviews the existing and proposed wastewater system for the Town of Samoa. It also analyzes the feasibility of constructing and operating new wastewater collection, treatment and disposal systems for the communities of Fairhaven and Finntown. It reviews proposed alternatives for collection, treatment and disposal and recommends the preferred alternative. The report then estimates construction and long term operation and maintenance costs for the preferred alternative, and prepares a preliminary rate analysis outlining the necessary user fees required to support the proposed system. Final recommendations are then outlined concerning the feasibility of the proposed system and the recommended next steps.

There are two separate wastewater treatment facilities currently in use at the Town of Samoa. The western system consists of a septic tank and leachfield. The eastern system consists of a septic tank, two unused bark filters, an oxidation treatment pond, and a percolation basin. The North Coast Regional Water Quality Control Board (NCRWQCB) has raised concerns about the impacts to groundwater quality from the existing system and would like to see an upgraded system in place. The towns of Fairhaven and Finntown, and the surrounding industrial properties currently do not have a centralized wastewater collection and treatment system, instead they operate off of individual septic systems with discharges to individual leachfields, with some industrial systems discharging to the existing ocean outfall. The NCRWQCB is concerned about the impacts of partially treated wastewater discharged to leachfields to groundwater and Humboldt Bay due to the Peninsula's high water table and sandy soils.

This PER is intended to be a thorough evaluation of the wastewater collection systems, treatment systems, and disposal options for the Town of Samoa, Fairhaven and Finntown. The main focus of this Planning Study is to evaluate the opportunities, identify approaches to address the constraints, and ultimately determine the path of future wastewater development on the Peninsula. Development of consolidated wastewater treatment for the Town of Samoa has begun separately through the development and implementation of the Samoa Town Master Plan by the Samoa Pacific Group (SPG). The Town of Samoa treatment plant has not yet been permitted by the NCRWQCB and SPG plans to eventually transfer control of the plant to the PCSD. As such, this PER will largely focus on designing a system for the entire PCSD service area given the cost savings potential of consolidating the wastewater treatment of the entire PCSD service area together.

Design Criteria

Design flows were developed for the peninsula, taking into account the existing population needs and the potential future needs with full build-out of the peninsula. Accounting for inflow and infiltration the existing average flow is approximately 60,000 gpd with a peak hour flow of 240,000 gpd, while future average daily flows could reach 200,000 gpd with a peak hour flow of 760,000 gpd. Design pollutant loads are based on literature value for typical medium-strength wastewater as there has been no testing of the potential influent raw wastewater.

The North Coast Regional Water Quality Control Board (NCRWQCB or Regional Board) is the agency to approve the waste discharge requirements and National Pollutant Discharge Elimination System (NPDES) permits. They have stated that the required level of treatment depends on the disposal location. Given the groundwater concerns on the peninsula and the NCRWQCB Basin Plan, Regional Board staff have said land disposal will require the water to be treated to USEPA primary drinking water standards, preferably with reverse osmosis for tertiary treatment. The other disposal option is through an existing ocean outfall pipe at the Redwood Marine Terminal II (RMT-II), which requires secondary treatment. Disinfection is also recommended for this alternative given the potential for fishing near the outlet.

Collection System

The proposed collection system consists of gravity flow pipes in the communities of Fairhaven and Finntown, connected by a single pressure pipe running north to a centralized WWTP near the Town of Samoa. Gravity pipe will be a minimum diameter of 8 inches to allow for easy access of cleaning and inspection equipment. Manholes will be placed a maximum of every 500 feet, at each change in vertical or horizontal alignment, within existing right of ways and streets, and at the end of every pipe run. Gravity mains and laterals will be constructed to prevent floatation during seismic events or due to high groundwater.

Each community will have at least one centralized pump station to pump raw wastewater to the WWTP through the central pressure main. The pressure main will include air relief valves at each rise in the pipe with air scrubbers to remove noxious gasses and odors. The pressure main will also include cleanout stations at each change in horizontal or vertical alignment, and at the end of every pipe run, for launching of a pipeline inspection gauge to clean the pipe when necessary.

Treatment System

For the treatment system primary treatment alternatives were included with the secondary treatment analysis based on the pre-treatment needs of the secondary treatment systems. The secondary treatment alternatives considered for the project are sequencing batch reactor (SBR), the AdvanTex process, and recirculating gravel filters (RGF). SBR is the most complex process, requiring a higher operator license and more operation and maintenance than the other alternatives. This complexity also allows for greater flexibility to meet the changing operational conditions while providing more reliable nitrate removal at a comparable capital cost to the lowest option, RGF. Despite the higher operational needs SBR was chosen as the preferred secondary treatment alternative as it is the most dependable system. For the SBR, primary treatment would include both bar screening and grit removal.

Reverse osmosis (RO) was the only tertiary treatment alternative. As suggested by Regional Board staff, this system would only be used if land disposal of effluent is chosen, as RO is otherwise an unnecessary and expensive addition to the treatment process.

Both chlorine and ultraviolet (UV) disinfection were considered. They are simple to operate, effective at killing pathogenic bacteria, and have similar operation and maintenance costs. UV was chosen as the preferred disinfection method as it has zero potential to create harmful by-products, has a smaller footprint, and a lower capital cost.

Seven sites were considered for placement of the treatment plant (Figure 6-11), they were compared based on the constraints that the site: be zoned Public Facility or Industrial General, minimize impacts to

environmentally sensitive habitat areas (ESHA), is available for purchase or lease for the lifetime of the project, minimize operational costs, have approximately 3 acres of available space, and is placed north of Fairhaven to allow for potential use of the RMT-II ocean outfall. The preferred site is the northern most site at the location of the proposed Town of Samoa wastewater treatment plant (WWTP) as this location meets all the above constraints and the permitting process has already begun to develop a WWTP the site. A second site at the RMT-II showed particular promise but is improperly zoned as Industrial Coastal Dependent, blocking use of a municipal wastewater treatment facility. An upcoming update to the Local Coastal Plan is attempting to rezone the site to Industrial General. Should the rezoning be finalized when the final survey and construction phase is beginning it is recommended to use this location due to reduced effluent transportation costs and the further distance from residential housing. The environmental analysis for this project should include both locations as potential alternatives.

Wastewater Disposal

Land and ocean disposal were the two wastewater disposal alternatives considered. Land disposal is limited to subsurface, leachfield disposal as there is not a need or space for recycled water irrigation on the peninsula. The leachfield would be placed at the treatment plant site and would require effluent treated through tertiary treatment and disinfection. While ocean disposal would utilize the RMT-II ocean outfall and would only require secondary treatment with disinfection recommended. The lower treatment standards make the ocean outfall the preferred disposal option. This option requires installation of an effluent disposal pipeline to the ocean outfall that will be constructed within existing roadways to reduce environmental impacts.

Solids Handling

The following four solid handling alternatives were considered:

- Contracting a local septic pumping service to remove and dispose of solids,
- Dewatering solids on-site and hauling dried solids to a landfill or composting operation,
- A facultative sludge lagoon (FSL) with land application of stabilized solids, and
- A thermal treatment system with land application of treated biosolids.

FSL was eliminated for odor considerations and thermal treatment was eliminated due to high costs. Cost comparison of the first two alternatives revealed significant lifetime savings by dewatering the solids on site, making that the preferred alternative.

Preferred Alternative Costs

The opinion of probable capital costs, including soft costs, and annual operation and maintenance costs for the preferred alternative consisting of a gravity collection system for Fairhaven and Finntown with a single pressure main connecting the two towns to the proposed WWTP site at the Town of Samoa, an SBR treatment system with UV disinfection located at the Samoa Townsite and disposal in the RMT-II ocean outfall can be found below (Table E-1). The table also shows the 30-year present worth of the project.



Table E-1: Opinion of probable capital and O&M costs with the 30-year present worth for the total preferred project.

| Item | Capital Cost | Annual O&M |
|--|---------------------|------------------|
| Collection System | \$5,800,000 | \$9,000 |
| Treatment - SBR and UV | \$1,830,000 | \$155,000 |
| Disposal - Ocean Outfall Line | \$610,000 | \$10,000 |
| Solids - Dewatering System | \$140,000 | \$40,000 |
| Construction Subtotal | \$8,380,000 | - |
| Permitting (5%) | \$420,000 | - |
| Legal, Administration | \$390,000 | - |
| Engineering Design and Construction Phases (20%) | \$1,680,000 | - |
| Geotechnical (5%) | \$420,000 | - |
| Contingency (20%) | \$1,680,000 | - |
| Total | \$13,000,000 | \$214,000 |

Operating Budget and Rate Schedule

Operation and maintenance expenses would be incurred by the District to provide sewer service to its customers. These expenses are accounted for during the current year and are not capitalized or amortized over an extended period of years. O&M costs include salaries and benefits, professional services, utilities, materials and supplies, and other items necessary to operate and maintain the sewer collection and treatment systems. Typically, when evaluating and setting rates for an agency, annual operating expenses have been well defined through years of operations along with reserve and capital improvement program requirements. However, as a “start-up” district, the PCSD has no previous expense data related to a wastewater program. O&M costs presented in the budget are reflective of costs presented in the project alternative analyses.

Considering the area is currently made up of 232 EDUs, (see Chapter 5) the initial projected monthly user rate per EDU (with 100% and 75% grant funding) is presented in Table E-2. Table E-2 also shows the expected rates with Phase 1 of the Town of Samoa expansion included as this build-out is expected to occur within a year or two of the development of a consolidate wastewater treatment system on the Samoa peninsula.

Table E-2: Projected Monthly User Rate per EDU

Existing EDUs - 232

| Item | Cost per EDU | |
|---------------------------|--------------|--------------|
| | 100% Grant | 75% Grant |
| O&M | \$77 | \$77 |
| Operating Reserve | \$3 | \$3 |
| Replacement Reserve | \$10 | \$10 |
| Debt Service | \$0 | \$51 |
| Total Monthly Rate | \$90 | \$141 |



Existing EDUs w/ Phase 1 Samoa Expansion - 338

| Item | Cost per EDU | |
|---------------------------|--------------|-------------|
| | 100% Grant | 75% Grant |
| O&M | \$53 | \$53 |
| Operating Reserve | \$2 | \$2 |
| Replacement Reserve | \$7 | \$7 |
| Debt Service | \$0 | \$35 |
| Total Monthly Rate | \$62 | \$97 |

The projected sewer rate of \$62 with 100% grant funding of the capital construction costs is within the range of rates for the local area (Table E-3). Without 100% grant construction funding, the rates would be well above the local area rates, may not be sustainable, and may prevent community support and acceptance of this proposed wastewater treatment system. It is vital that the capital costs be covered in full to make the project economically feasible and sustainable in the long term.

Table E-3: Comparison of the monthly sewer rate per single residence releasing 100 cubic feet of wastewater for the local municipalities and community services districts.

| Community | Monthly Sewer Rate |
|-------------------------|--------------------|
| City of Arcata | \$49 |
| City of Eureka | \$30 |
| McKinleyville CSD | \$37 |
| Proposed Town of Samoa | \$50 |
| Fieldbrook-Glendale CSD | \$70 |
| Humboldt CSD | \$25 |
| Manila CSD | \$40 |

Conclusions and Next Steps

This preliminary engineering report (PER) has analyzed alternatives for providing community sewer service to the Samoa Peninsula. The apparent best project includes a reliable treatment and disposal system that should be easy to operate and maintain.

This PER has been completed with funds received from the SWRCB, Clean Water State Revolving Fund Small Community Planning Grant. This grant was awarded in July 2017. GHD and SHN have been working with the Peninsula CSD to complete this PER. The following next steps are scheduled to occur, using the remaining grant funds.

1. An EIR, as outlined by Title 14 of CEQA, for the Samoa Peninsula Wastewater Project will begin after the approval of the PER by the County and the District Board. The EIR process will address and evaluate the potential environmental impacts of the project and incorporate mitigation measures where feasible.

A required and critical piece of the EIR process is public input. CEQA does not require public meetings at any stage of the environmental review process; however, an initial scoping



meeting and a public hearing on the Draft EIR are recommended and will be conducted as part of this process. These meetings will provide the opportunity to inform the public of the project, and receive input on environmental issues associated with the project.

2. The construction of a combined WWTP site at the existing Samoa townsite WWTP location will require a Local Coastal Plan (LCP) amendment to the Samoa Town Master Plan in the Humboldt Bay Area Plan. Discussion should be conducted with the California Coastal Commission (CCC) and SPG to instigate this update. Alternatively, the WWTP site could be moved to the RMT-II if the zoning of this site is successfully changed to General Industrial. Discussions should continue with the Humboldt Bay Harbor, Recreation and Conservation District, the CCC and Humboldt County on this alternative.
3. SHN will complete a report of waste discharge (ROWD) application for the District, which is a necessary part of the wastewater system development and implementation. The NCRWQCB will issue a new NPDES permit and associated WDRs, which will be based in part on the ROWD, which will describe the new collection system, treatment facilities, and disposal practices. This process includes completion of Form 200 which is submitted to the state.
4. Submit funding applications to federal and state agencies. GHD will assist the District in the completion of the grant applications for final design and construction funds. The level of grant funds received will determine the actual user costs for the project.

DRAFT



Table of Contents

| | | |
|-------|---|----|
| 1. | Introduction and Planning History | 1 |
| 1.1 | Summary of Previous Related Studies..... | 1 |
| 1.1.1 | Peninsula CSD Formation Reports..... | 2 |
| 1.1.2 | Industrial Infrastructure Assessment Reports | 7 |
| 1.1.3 | Town of Samoa Development Documents..... | 9 |
| 1.1.4 | Phase I and Phase II Environmental Site Assessment Reports | 10 |
| 2. | Project Planning Area..... | 14 |
| 2.1 | Location and Development of Wastewater Service Area Boundaries..... | 14 |
| 2.2 | Land Use..... | 14 |
| 2.2.1 | Town of Samoa | 17 |
| 2.2.2 | Fairhaven | 17 |
| 2.2.3 | Finntown..... | 17 |
| 2.2.4 | Industrial Uses..... | 18 |
| 2.2.5 | Commercial Uses | 18 |
| 2.2.6 | Recreational Uses | 18 |
| 2.2.7 | Federal Property..... | 18 |
| 2.3 | Current and Future System Users | 18 |
| 2.4 | Population Trends | 19 |
| 2.4.1 | Town of Samoa | 19 |
| 2.4.2 | Fairhaven | 20 |
| 2.4.3 | Finntown..... | 23 |
| 2.4.4 | Other..... | 23 |
| 3. | Existing Facilities..... | 23 |
| 3.1 | History..... | 23 |
| 3.2 | Town of Samoa Wastewater Facilities | 24 |
| 3.2.1 | Existing Town of Samoa Collection System..... | 24 |
| 3.2.2 | Existing Town of Samoa Treatment System | 25 |
| 3.2.3 | Existing Town of Samoa Disposal System..... | 26 |
| 3.2.4 | Existing Town of Samoa Solids Handling | 29 |
| 3.2.5 | Financial Status of Existing Facilities..... | 29 |
| 3.2.6 | Water Quality..... | 29 |
| 3.2.7 | Planned Upgrades | 31 |
| 3.2.8 | Regulatory Compliance..... | 31 |
| 3.2.9 | Asset, Operation, and Maintenance Management Systems..... | 32 |
| 4. | Need for Project | 32 |
| 4.1 | Regulatory Compliance Issues | 33 |
| 4.2 | Groundwater and Surface Water Monitoring | 34 |
| 4.3 | Infrastructure Issues | 37 |
| 5. | Development of Design Flows and Loads | 37 |
| 5.1 | Design Flow Definitions | 38 |



| | | |
|--------|--|-----|
| 5.2 | Industrial Flows | 39 |
| 5.3 | Equivalent and Accessory Dwelling Units | 40 |
| 5.4 | Base Sanitary Flows..... | 41 |
| 5.5 | Peaking Factors | 48 |
| 5.6 | Inflow and Infiltration..... | 48 |
| 5.6.1 | Base I/I..... | 49 |
| 5.6.2 | Wet Weather I/I..... | 50 |
| 5.7 | Design Flows..... | 51 |
| 5.8 | Pollutant Loads | 53 |
| 6. | Alternatives Analysis | 54 |
| 6.1 | Collection System..... | 54 |
| 6.1.1 | Collection System Description..... | 54 |
| 6.1.2 | Collection System Alternatives..... | 62 |
| 6.1.3 | Collection System Design Criteria..... | 73 |
| 6.1.4 | Collection System Potential Environmental Impacts | 75 |
| 6.1.5 | Collection System Land and Permitting Requirements | 75 |
| 6.1.6 | Collection System Construction Issues..... | 76 |
| 6.1.7 | Collection System Opinion of Probable Cost | 77 |
| 6.1.8 | California Government Code Section 65041.1..... | 80 |
| 6.1.9 | Climate Change Considerations..... | 81 |
| 6.1.10 | Opportunities for Water and Energy Efficiency | 81 |
| 6.1.11 | Comparison of Collection System Alternatives | 82 |
| 6.2 | Wastewater Treatment System..... | 84 |
| 6.2.1 | Treatment System Description | 84 |
| 6.2.2 | Treatment System Alternatives | 85 |
| 6.2.3 | Treatment System Design Criteria..... | 89 |
| 6.2.4 | Treatment System Potential Environmental Impacts..... | 90 |
| 6.2.5 | Treatment System Land and Permitting Requirements..... | 90 |
| 6.2.6 | Treatment System Opinion of Probable Cost..... | 93 |
| 6.2.7 | Comparison of Wastewater Treatment System Alternatives | 94 |
| 6.3 | Wastewater Disposal..... | 96 |
| 6.3.1 | Wastewater Disposal Description..... | 96 |
| 6.3.2 | Wastewater Disposal Alternatives..... | 96 |
| 6.3.3 | Wastewater Disposal Design Criteria | 97 |
| 6.3.4 | Wastewater Disposal Potential Environmental Impacts | 97 |
| 6.3.5 | Wastewater Disposal Land and Permitting Requirements..... | 98 |
| 6.3.6 | Wastewater Disposal Opinion of Probable Cost | 98 |
| 6.3.7 | Comparison of Wastewater Disposal Alternatives..... | 100 |
| 6.4 | Solids Handling | 100 |
| 6.4.1 | Solids Handling Description | 100 |
| 6.4.2 | Solids Handling Alternatives..... | 101 |
| 6.4.3 | Solids Handling Design Criteria..... | 102 |
| 6.4.4 | Solids Handling Potential Environmental Impacts..... | 103 |
| 6.4.5 | Solids Handling Land and Permitting Requirements..... | 103 |
| 6.4.6 | Solids Handling Opinion of Probable Cost..... | 103 |
| 6.4.7 | Comparison of Solids Handling Alternatives | 104 |



| | | |
|-------|---|-----|
| 7. | Apparent Best Project..... | 105 |
| 7.1 | Preliminary Project Design | 105 |
| 7.1.1 | Collection System | 105 |
| 7.1.2 | Treatment System and Treated Water Disposal | 106 |
| 7.1.3 | Solids Dewatering and Disposal..... | 109 |
| 7.2 | Total Project Opinion of Probable Cost | 110 |
| 7.2.1 | Collection System | 110 |
| 7.2.2 | Wastewater Treatment System | 112 |
| 7.2.3 | Wastewater Disposal | 113 |
| 7.2.4 | Solids Handling and Disposal..... | 113 |
| 7.2.5 | Total Project Opinion of Probable Cost..... | 114 |
| 7.3 | Permitting for Proposed Project | 115 |
| 7.4 | Waste Discharge Requirements | 116 |
| 7.5 | Key Issues for the Proposed Project..... | 117 |
| 7.5.1 | Collection System | 117 |
| 7.5.2 | Treatment System | 117 |
| 7.5.3 | Permitting | 118 |
| 7.5.4 | Other | 118 |
| 7.5.5 | Funding | 118 |
| 7.6 | Preliminary Operating Budget and Rate Schedule | 118 |
| 7.6.1 | Operation, Maintenance, and Replacement Costs..... | 119 |
| 7.6.2 | Reserves | 121 |
| 7.6.3 | Debt Service..... | 123 |
| 7.6.4 | Preliminary Rate Schedule..... | 124 |
| 7.7 | Community Engagement | 126 |
| 7.8 | Project Schedule | 126 |
| 8. | Conclusions, Recommendations, and Next Steps..... | 127 |
| 8.1 | Next Steps within Current Grant | 127 |
| 9. | References..... | 129 |
| | Appendix A – Wetland Delineation:..... | 135 |
| | Appendix B – WDR No. R1-2001-62..... | 137 |
| | Appendix C – WDR No. R1-2012-0027..... | 139 |
| | Appendix D – Town of Samoa Wastewater Flow and..... | 141 |
| | Appendix E – National Primary Drinking Water Regulations..... | 143 |
| | Appendix F – Treatment System Cost Estimates | 145 |
| | Appendix G – EcoCycle SBR Details | 147 |
| | Appendix H – Trojan UV Fit Details | 149 |

Figure Index

| | |
|---|-----|
| Figure 1-1: Vicinity Map..... | 3 |
| Figure 1-2: Project Service Area..... | 5 |
| Figure 1-3: Samoa Peninsula Groundwater Cleanup and Monitoring Sites..... | 11 |
| Figure 2-1: Zoning Map..... | 15 |
| Figure 2-2: Fairhaven Parcel Count..... | 21 |
| Figure 3-1: Town of Samoa Existing Sewer System..... | 27 |
| Figure 4-1: Samoa Peninsula Groundwater Monitoring Sites and Data Summary | 35 |
| Figure 4-2: Tidal Study Water Elevations..... | 37 |
| Figure 6-1: Proposed Samoa Peninsula Wastewater Collection and Conveyance System. | 55 |
| Figure 6-2: Proposed Town of Samoa Wastewater Collection and Conveyance System. | 59 |
| Figure 6-3: Proposed Fairhaven Gravity Wastewater Collection and Conveyance System. | 63 |
| Figure 6-4: Proposed Finntown Gravity Wastewater Collection and Conveyance System. | 65 |
| Figure 6-5: Proposed Fairhaven Pressurized Wastewater Collection and Conveyance System..... | 69 |
| Figure 6-6: Proposed Finntown Pressurized Wastewater Collection and Conveyance System..... | 71 |
| Figure 6-7: Overview of the typical SBR process | 86 |
| Figure 6-8: General flow diagram of recirculating gravel filter system..... | 87 |
| Figure 6-9: Typical spiral-wound RO membrane module (Davis, 2010)..... | 88 |
| Figure 6-10: Typical hollow fiber RO membrane module (Davis, 2010). | 88 |
| Figure 6-11: Potential Wastewater Treatment Sites | 91 |
| Figure 7-1: Proposed Samoa Peninsula Wastewater Collection and Treatment Systems Layout.... | 107 |

Table Index

| | |
|---|----|
| Table 2-1: Proposed development and sewer connections in the Town of Samoa Master Plan (CEC, 2015). | 19 |
| Table 3-1: Existing Town of Samoa treatment system effluent limitations (NCRWQCB, 2014). | 26 |
| Table 3-2: Existing Town of Samoa treatment system flow capacity (NCRWQB, 2014)..... | 26 |
| Table 5-1: Estimated base sanitary wastewater users and flow rates for existing and proposed facilities in the PCSD service area..... | 43 |



Table 5-2: Estimated wastewater users and flow rates for existing and proposed facilities on the Samoa peninsula including recreational, industrial, and federal properties not included in Table 5.1 above..... 46

Table 5-3: Estimated base sanitary wastewater flow rates for existing and proposed users in the Peninsula Community Services District service area according to user class¹. 47

Table 5-4: Estimated base sanitary wastewater flow rates for existing and proposed users in the Town of Samoa, according to STMP Phase¹..... 47

Table 5-5: Estimated EDUs¹ for existing and proposed users in the Peninsula Community Services District service area according to user class². 47

Table 5-6: PCSD gravity sewer pipe length estimates..... 49

Table 5-7: Estimated base inflow and infiltration for PCSD gravity sewer system. 50

Table 5-8: Estimated wet weather inflow and infiltration for PCSD gravity sewer system..... 51

Table 5-9: Estimated design sanitary wastewater flow rate summary for the Peninsula Community Services District service area for a gravity sewer system. 52

Table 5-10: Typical untreated domestic wastewater pollutant concentrations and loads..... 53

Table 6-1: List of alternatives considered for each project component. 54

Table 6-2: Potential sewer connections in the PCSD¹ service area..... 58

Table 6-3: Town of Samoa existing and proposed sewer connections by development phase¹. 61

Table 6-4: Opinion of probable project cost for gravity sewer system. 77

Table 6-5: Opinion of probable operation and maintenance cost for gravity sewer system. 78

Table 6-6: Opinion of probable project cost for pressure sewer system..... 79

Table 6-7: Opinion of probable operation and maintenance cost for pressure sewer system. 80

Table 6-8: Opinion of probable lifecycle cost for sewer collection system alternatives. 80

Table 6-9: 30-year present worth costs for the treatment system alternatives 94

Table 6-10: Advantages and disadvantages of treatment alternatives..... 95

Table 6-11: Opinion of probable construction cost for a leachfield including the cost for the tertiary treatment, reverse osmosis system, required for land disposal of effluent on the peninsula. 99

Table 6-12: Opinion of probable construction cost for an ocean outfall connection..... 99

Table 6-13: 30-year present worth costs for the disposal systems..... 100

Table 6-14: Advantages and disadvantages of wastewater disposal alternatives 100

Table 6-15: Opinion of probable construction cost for an on-site dewatering system. 104

Table 6-16: 30-year Present Worth Costs for the Solids Handling Systems..... 104

Table 7-1: Opinion of probable project cost for gravity sewer system. 111



Table 7-2: Opinion of probable annual operation and maintenance cost for gravity sewer system. . 112

Table 7-3: Opinion of probable cost for the wastewater treatment system including primary, secondary, and disinfection treatment. 112

Table 7-4: Opinion of probable operation and maintenance cost for the treatment system. 113

Table 7-5: Opinion of probable cost for the disposal pipeline to the ocean outfall. 113

Table 7-6: Opinion of probable operation and maintenance cost for the solids handling system. 114

Table 7-7: Opinion of probable capital and O&M costs with the 30-year present worth for the total project. 115

Table 7-8: Short Lived Assets..... 121

Table 7-9: Funding Scenarios 124

Table 7-10: Projected Monthly User Rate per EDU..... 125

Table 7-11: Comparison of the monthly sewer rate per single residence releasing 100 cubic feet of wastewater for the local municipalities and community services districts. 125

Appendix Index

Appendix A Wetland Delineation: RMTII Samoa Effluent Pipeline, Samoa, California
SHN, 2017

Appendix B WDR No. R1-2001-62
Town of Samoa Wastewater Treatment Facilities

Appendix C WDR No. R1-2010-0027
DG Fairhaven Power Facility

Appendix D Town of Samoa Wastewater Flow and Dispersal Area Study
CEC, 2015

Appendix E National Primary Drinking Water Regulations
USEPA

Appendix F Treatment System Cost Estimates

Appendix G EcoCycle SBR Details

Appendix H Trojan UV Fit Details



1. Introduction and Planning History

This Preliminary Engineering Report (PER) has been completed for the County of Humboldt to evaluate the future of wastewater on the Samoa Peninsula. The purpose of this PER is to assess the feasibility of a consolidated wastewater collection, treatment, and disposal system for residential, commercial/industrial, recreational, and institutional facilities located within the boundaries of the proposed Peninsula Community Services District (PCSD) (see Figure 1-1 and Figure 1-2). This Report reviews the existing and proposed wastewater system for the Town of Samoa. It also analyzes the feasibility of constructing and operating new wastewater collection, treatment and disposal systems for the communities of Fairhaven and Finntown. It reviews proposed alternatives for collection, treatment and disposal and recommends the preferred alternative. The report then estimates construction and long term operation and maintenance costs for the preferred alternative, and prepares a preliminary rate analysis outlining the necessary user fees required to support the proposed system. Final recommendations are then outlined concerning the feasibility of the proposed system and the recommended next steps.

There are two separate wastewater treatment facilities currently in use at the Town of Samoa. The western system consists of a septic tank and leachfield. The eastern system consists of a septic tank, two unused bark filters, an oxidation treatment pond, and a percolation basin. The North Coast Regional Water Quality Control Board (NCRWQCB) has raised concerns about the impacts to groundwater quality from the existing system and would like to see an upgraded system in place. The towns of Fairhaven and Finntown, and the surrounding industrial properties currently do not have a centralized wastewater collection and treatment system, instead they operate off of individual septic systems with discharges to individual leachfields, with some industrial systems discharging to the existing ocean outfall. The NCRWQCB is concerned about the impacts of partially treated wastewater discharged to leachfields to groundwater and Humboldt Bay due to the Peninsula's high water table and sandy soils.

This PER is intended to be a thorough evaluation of the wastewater collection systems, treatment systems, and disposal options for the Town of Samoa, Fairhaven and Finntown. The main focus of this Planning Study is to evaluate the opportunities, identify approaches to address the constraints, and ultimately determine the path of future wastewater development on the Peninsula. Development of consolidated wastewater treatment for the Town of Samoa has begun separately through the development and implementation of the Samoa Town Master Plan (STMP) by the Samoa Pacific Group (SPG). The Town of Samoa treatment plant has not yet been permitted by the NCRWQCB and SPG plans to eventually transfer control of the plant to the PCSD. As such, this PER will largely focus on designing a system for the entire PCSD service area given the cost savings potential of consolidating the wastewater treatment of the entire PCSD service area together.

1.1 Summary of Previous Related Studies

Previous projects and studies have been completed in the proposed PCSD service area that include relevant information for the planning, permitting, funding, and construction of wastewater



collection and treatment systems. These studies can generally be grouped according to four main categories:

1. Peninsula CSD formation reports
2. Industrial infrastructure assessment reports
3. Town of Samoa development documents
4. Phase I and Phase II environmental site assessment reports

1.1.1 Peninsula CSD Formation Reports

Plan for Services for Reorganization of the Samoa Peninsula Fire Protection District (CEC, July 2015a)

This report describes existing and proposed utilities on the peninsula focusing on the STMP. The utilities described include water, wastewater, electrical, natural gas, roads, telecommunication, and emergency services, focusing on water and wastewater for the Town of Samoa. Proposed land-use, construction phasing, and utilities described in this report can also be found in the draft master environmental impact report (DEIR) dated January 2006 (Humboldt County, 2006) and the wastewater report of waste discharge (ROWD) dated September 2015 (CEC, 2015).

Samoa Peninsula Fire District Fiscal Analysis- Data Sheets for Possible LAFCO Reorganization (CEC, 2015b)

This document includes a proposed organization chart for the Samoa Peninsula Fire Protection District (SPFPD), and existing and projected operating revenues and expenses for the proposed PCSD. Operating revenues of \$989,344 and expenses of \$894,040 were projected, including a general fund, fire department operating fund, and water and sewer operating and improvement funds. Note that no sewer service was proposed for any area outside the STMP area. Costs were projected to be \$428 per year for Fairhaven residents and \$1,716 per year for Town of Samoa residents.



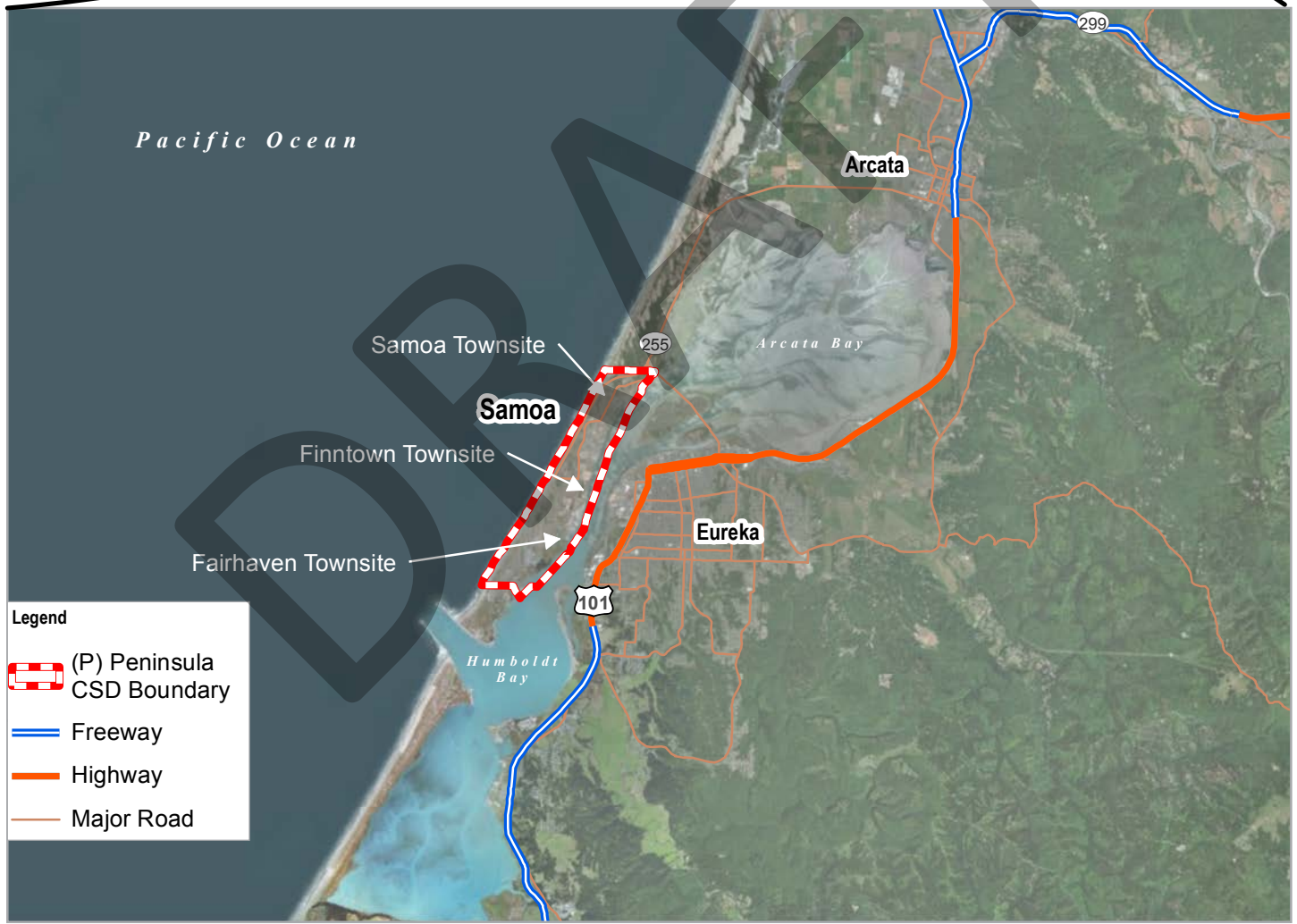
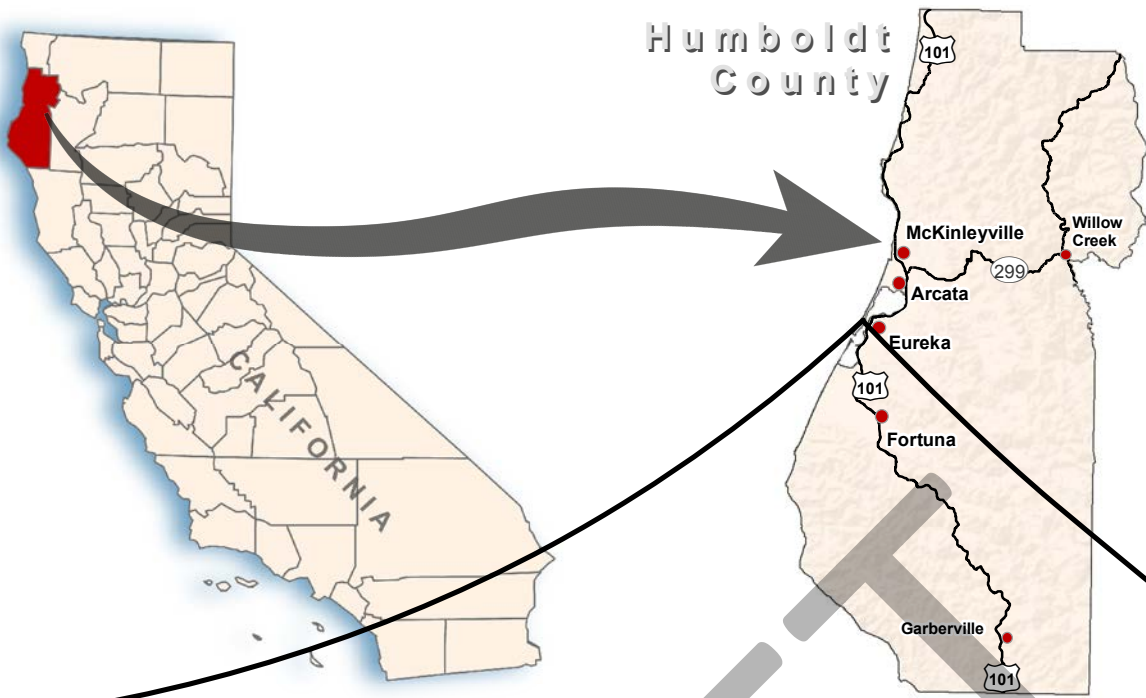

Management Plan, Peninsula CSD Formation (SHN, 2017a)

This report was prepared to support the application to LAFCo to reorganize the SPFPD into the PCSD. The report describes existing infrastructure and services in the proposed PCSD service area, including water, wastewater, roads, storm drainage, and parks and recreation. Growth projections for the town of Fairhaven include 70-90 additional homes; it should be noted that this assessment was completed prior to the in-depth analysis of existing and proposed buildable lots conducted by the Humboldt County Community Development Services Department, SHN, and GHD as a part of the current study.

This report describes services to be provided by the proposed PCSD for two zones, including the STMP zone and the Fairhaven/Industrial zone, as well as district formation tasks required for full implementation of a new district. This report also includes financial planning objectives, methodology, and a 5-year financial plan for District startup.



Legend

-  (P) Peninsula CSD Boundary
-  Freeway
-  Highway
-  Major Road

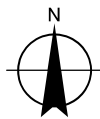
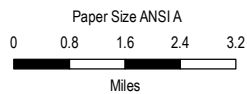

County of Humboldt
 Samoa Peninsula
 Wastewater Planning Study

Project No. 11146487
 Revision No. -
 Date February 2018

Vicinity Map

FIGURE 1.1

DRAFT

PACIFIC OCEAN

Legend

- Samoa Town Master Plan Area
- (P) Peninsula CSD Boundary



Data Disclaimer
 Proposed Samoa Peninsula Community Services District (SPCSD) boundary dependent upon Humboldt County Local Area Formation Commission (LAFCo) approval.

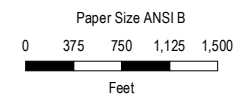

Map Projection: Lambert Conformal Conic
 Horizontal Datum: North American 1983
 Grid: NAD 1983 StatePlane California I FIPS 0401 Feet



County of Humboldt
 Samoa Peninsula
 Wastewater Planning Study

Project No. SHN017203
 Revision No. -
 Date Mar 2018

Project Service Area

FIGURE 1.2

\\Eureka\Projects\2017012003-Samoa Peninsula Wastewater design-plan of study\002-PDR\GIS\PROJ_MXD\GHD_MXD\Fig1_2_ServiceArea.mxd
 Print date: 08 Mar 2018 - 12:26

Data source: Source: Esri, DigitalGlobe, GeoEye, Earthstar Geographics, CNES/Airbus DS, USDA, USGS, AeroGRID, IGN, and the GIS User Community. Created by SHN: cswanson

DRAFT



Samoa Peninsula Wastewater Legal Parcel Study Analysis (County of Humboldt, 2017)

This study included an investigation into the number of legal, developed, undeveloped, and merged parcels in the town of Fairhaven for the purposes of assessing wastewater service needs. The original 1908 parcel map for the area is not officially recognized, and no other official parcel map has been created. A final determination of parcel subdivision was not determined; however, it was noted that a legal determination of parcel number and location would require a full title history search. Letters were sent to property owners; however, only one chain of title was received. The study concluded that there may be 61 parcels developed with individual septic systems, and that there are potentially 113 parcels that could be developed, only 90 of which had a high probability of being developed. Included in this study is a series of four maps identifying parcel ownership and current development status.

1.1.2 Industrial Infrastructure Assessment Reports

Samoa Industrial Waterfront Preliminary Transportation Access Plan (LACO, 2013a)

This report documents the Humboldt Bay Harbor, Recreation and Conservation District's (HBHRCD's) planning efforts to improve transportation and movement of goods and services on the Samoa Peninsula. This study is part of a larger effort by the HBHRCD to attract new industrial interests to the peninsula to inhabit the existing industrial facilities, and maintain existing tenants that make up the post-timber industry on the peninsula. The evaluation of transportation alternatives for the peninsula included stakeholder outreach, evaluation of existing conditions, opportunities and constraints, cost estimates, permitting requirements, alternatives analysis, project prioritization, funding opportunities, and traffic volume estimates.

The alternatives include consideration of a railway loop on the peninsula, connecting existing rail lines to potential regional rail lines for importation and exportation of goods, and movement of goods between various properties on the peninsula. Regional railway connectivity was deemed less feasible than roadway improvements for our region, therefore more focus was placed on development and improvement of the roadways on the peninsula to facilitate potential industrial traffic.

Infrastructure Needs and Reuse on the Samoa Peninsula: Redwood Marine Terminal II (SHN, 2016)

This report includes a preliminary assessment of the industrial infrastructure at RMT-II, and a planning-level feasibility study of potential uses for the existing infrastructure, permitting requirements, and cost estimates. The infrastructure assessment included the water treatment system, the on-site septic and leachfield systems, the ocean outfall, and the outfall pump station. The feasibility study included evaluation of industrial-scale aquaculture, the feasibility of treating dredge spoils using the on-site water treatment infrastructure, and the feasibility of using the ocean outfall for disposal of on-site and off-site wastewater.

Industrial infrastructure at RMT-II includes the following:

- The water treatment system includes a chemical feed system, two 1.5 million gallon (MG) clarifiers, ten pressure filters, and four softeners originally used by the pulp mill to treat raw



Mad River water from the HBMWD pump station. The design capacity of the treatment system is 30 million gallons per day (MGD) with a peak flow capacity of 25,000 gallons per minute (gpm), and a design influent loading of 100 nephelometric turbidity units (NTU).

- The ocean outfall is 1.5 miles-long, 48 inches in diameter, and has a hydraulic capacity of 40 MGD. The pump station that discharges to the ocean outfall (Manhole 5) includes two 350-horsepower (hp) pumps.
- RMT-II has an on-site leachfield system that is split in two between domestic wastewater generated on site, and aquaculture wastewater generated on site.

The feasibility study investigated alternatives for handling of dredge spoils from Humboldt Bay. It was estimated that 30,000 cubic yards of solids must be removed annually. Alternatives included discharge through the ocean outfall, dewatering using the clarifiers, and dewatering using geotubes. Currently, dredge spoils are hauled offshore and dumped. Discharge to the ocean outfall was eliminated as an alternative because turbidity must be below 75 NTU for the permitted ocean outfall discharge point. Dewatering the slurry would allow overland disposal of the solids, returning the supernatant to either the bay or the ocean.

The feasibility study also evaluated use of the ocean outfall for disposal of on-site and off-site wastewater. On-site wastewater sources may include dredge supernatant and aquaculture wastewater. Off-site wastewater sources may include industrial wastewater from other sites on the peninsula, and municipal wastewater from nearby communities including the City of Eureka. A waste load estimation was completed for potential industrial aquaculture activities based on the hydraulic capacity of the ocean outfall.

Humboldt Mill Outfall Evaluation (*Cosmopolitan Marine Engineering, 2016*)

This inspection report describes the location of two ocean outfalls originating at the former Simpson Mill in Fairhaven (currently the Fairhaven Business Park) as a part of a preliminary wastewater disposal alternatives evaluation conducted by the City of Eureka. This outfall is separate and distinct from the outfall originating at the RMT-II facility. The inspection included echo sounding of the ocean floor to locate and map the two outfalls, and a video inspection of the northern outfall with a remotely operated vehicle (ROV) equipped with a camera. Water visibility was too poor to acquire a thorough video inspection, so a diver inspection was recommended to determine the condition of the pipe, joints, and diffusers. This inspection is the only record of the conditions of the outfalls since the mill closed in 1994.

Both pipes were constructed of American Water Works Association (AWWA) Class 300 concrete cylinder pipe (CCP), approximately 2,800 feet long, with approximately 200-foot long diffusers at the ends. The northern outfall pipe is 36-inch CCP and the southern outfall pipe is 48-inch CCP. According to the report, the acoustic survey found the diffusers intact.

The two outfall pipes join at a wye above the surf zone, converging to a single 48-inch wood stave pipe. The junction and valves were placed in a valve house that has been demolished. Upstream of the wye, the pipe includes approximately 3,000 feet of wood stave pipe that is in disrepair due to corroded bands. Downstream of the wye, the southern outfall pipe was damaged in 1987 and blocked off, leaving only the northern outfall functional. The condition of the southern outfall pipe is



unknown. The northern outfall pipe was slip-lined with 30 inch (inside diameter) high-density polyethylene (HDPE) standard dimension ratio (SDR) 32 from the wye to 2,500 feet offshore to the diffuser. Additional improvements and repairs were made to the northern outfall between 1987 and 1994; however, further inspection, testing, and repairs would be necessary to bring this outfall back into operation.

Samoa Pulp Mill Infrastructure Analysis: Redwood Marine Terminal II (SHN, 2017d)

This report builds on the previous infrastructure needs and reuse report (SHN, 2016) developing draft National Pollutant Discharge Elimination System (NPDES) permit applications for two of the three potential wastewater discharges to the ocean outfall at RMT-II. The DG Fairhaven biomass power plant has an existing NPDES permit to discharge to the ocean outfall at a rate of approximately 170,000 gpd; this report included an evaluation of wastewater from the proposed Town of Samoa wastewater treatment facility (WWTF) and potential industrial aquaculture activities at RMT-II. This report also includes a natural resource assessment along the proposed pipe alignment from the proposed Town of Samoa WWTF to the ocean outfall pump station at Manhole 5 located at RMT-II.

1.1.3 Town of Samoa Development Documents

Samoa Town Master Plan Draft Master Environmental Impact Report (Humboldt County, 2006)

This report describes the STMP for development. It outlines the phasing involved in the development of the Town of Samoa, evaluates potential environmental impacts associated with the project, and describes water and wastewater infrastructure improvements.

Ultimately, the final EIR was approved in a notice of determination by the Humboldt County Board of Supervisors with a County General Plan Amendment in February 2008 (State Clearinghouse Number 2003052054).

Application/Report of Waste Discharge- Town of Samoa Project Description – 4th Submittal (CEC, 2015)

This ROWD was the fourth submittal by the California Engineering Company (CEC) to the North Coast Regional Water Quality Control Board (RWQCB) to apply for waste discharge requirements (WDRs) for discharge of treated wastewater to land in the Town of Samoa. This ROWD includes updated WWTF design specifications and description. This ROWD has not been approved at this time, and no discharge permit has been issued by the RWQCB.

Groundwater Modeling Report: Proposed Wastewater Treatment Facility, Samoa, California (SHN, 2015)

A groundwater modeling study was conducted for the Town of Samoa in 2015 by SHN as a part of the proposed alternative to discharge wastewater to a disposal field (SHN, 2015). The RWQCB published a draft WDR (Order No. R1-2014-0031) proposing new discharge limits for a proposed WWTF to serve the community development project described under the STMP. The study was conducted as a part of an anti-degradation analysis required by the RWQCB to demonstrate that the proposed project would not degrade groundwater quality. The study demonstrated that the



proposed discharge would not result in degradation of groundwater quality above objectives established by the Basin Plan (RWQCB, 2011). However, the study indicated that the proposed disposal field size may be inadequate, resulting in a hydraulic loading rate that exceeded the maximum Basin Plan loading rate for a land-based disposal field. The STMP has since been modified to increase the size of the proposed disposal fields accordingly (CEC, 2015).

The 2015 groundwater modeling study included a subsurface investigation consisting of pneumatic slug tests, cone penetration tests, water surface elevation monitoring, and depth-discrete groundwater sampling. Data from the subsurface investigation were used to model groundwater mounding, groundwater mixing, and nitrate transport.

Report of Waste Discharge, Town of Samoa Wastewater Treatment Facility (*SHN, 2017c*)

This ROWD was submitted to the RWQCB to apply for an NPDES discharge permit to the Pacific Ocean through the 1.5-mile long ocean outfall pipe at RMT-II, owned by the HBHRCD. However, no discharge permit has been issued yet by the RWQCB. The RWQCB is currently reviewing the NPDES permit application from the Town of Samoa for discharge to the ocean outfall.

Wetland Delineation, RMT-II Samoa Effluent Pipeline (*SHN, 2017f – Appendix A*)

This report builds off of the natural resources assessment conducted as a part of the RMT-II infrastructure analysis previously described (*SHN, 2017d*). The wetlands delineation is another step in the permitting process required for construction of the pressure pipe from the proposed Town of Samoa WWTF to the ocean outfall discharge pump station at Manhole 5 located at RMT-II. The proposed pipe alignment follows existing roads to minimize impacts to sensitive environmental areas on the peninsula.

1.1.4 Phase I and Phase II Environmental Site Assessment Reports

Environmental conditions in relative proximity to the proposed alignment for a PCSD wastewater sewer collection and conveyance system, which are presented in publicly available documents, were reviewed in an effort to identify potential sources of soil and groundwater contamination resulting from historical land uses. Sources of information reviewed include that which is available on the State of California Geotracker website, and information available for review on the HBHRCD website. Efforts were made to secure Phase I environmental site assessment (ESA) reports funded through the Humboldt County Economic Development Prosperity Center (HCEC) by EPA Brownfields grants by contacting county agencies and the EPA, but this information was not secured in the timeframe of these research efforts. Documents reviewed include Phase I and II ESAs, reports, deed restrictions, and soil management contingency plans (SMCP) related to environmental assessment and cleanup performed under the oversight of the RWQCB and Local Oversight Program, and one report from the Department of the Army related to conditions at the former Air Base located on the peninsula.

Several of the sites identified through research are located off of the proposed alignment, and current conditions are not interpreted to pose a threat to worker health and safety (Figure 1-3). These sites include:

Site 1: Simpson-Samoa Wood Mill (Town of Samoa)

Site 2: Simpson Timber Company Samoa (Town of Samoa)

PACIFIC OCEAN

Legend

- Samoa Town Master Plan Area
- (P) Peninsula CSD Boundary

Site 4
Numerous Samoa Peninsula:
broad area, Cookhouse garage, Hammond power house, soccer field garage, soccer field, Lorenzo's buildings, wastewater pond, unlined burn pit, railroad rigging shop
 RWQCB Case No. 1NHU890
Potential Constituents of Concern:
SVOC, petroleum, chromium, lead, arsenic, TCE

Site 3
Lorenzo's Shell
 LOP No. 12800
Potential Constituents of Concern:
Gasoline, Diesel, Motor Oil

Site 5
LP Samoa Mill
 1NHU892
Potential Constituents of Concern:
metals, petroleum

Site 7
Fairhaven Business Park
 RWQCB Case No. 1THU932
Potential Constituents of Concern:
Petroleum

Site 2
Simpson Timber Company Samoa
 RWQCB Case No. 1NHU764
Potential Constituents:
Lead, Dioxins/Furans, Hydrocarbons

Site 1
Simpson-Samoa Wood Mill
 RWQCB Case No. 1THU719
Potential Constituents:
Gasoline, Diesel, Motor Oil

Site 6
Simpson Paper Humboldt Pulp Mill
 RWQCB Case No. 1NHU055
Potential Constituents of Concern:
diesel

Site 8
Samoa Peninsula Fire Protection District
 RWQCB Case No. 1THU297
Potential Constituents of Concern:
Petroleum

Site 9
Samoa Air Base
 RWQCB Case No. none
Potential Constituents of Concern:
Petroleum

HUMBOLDT BAY

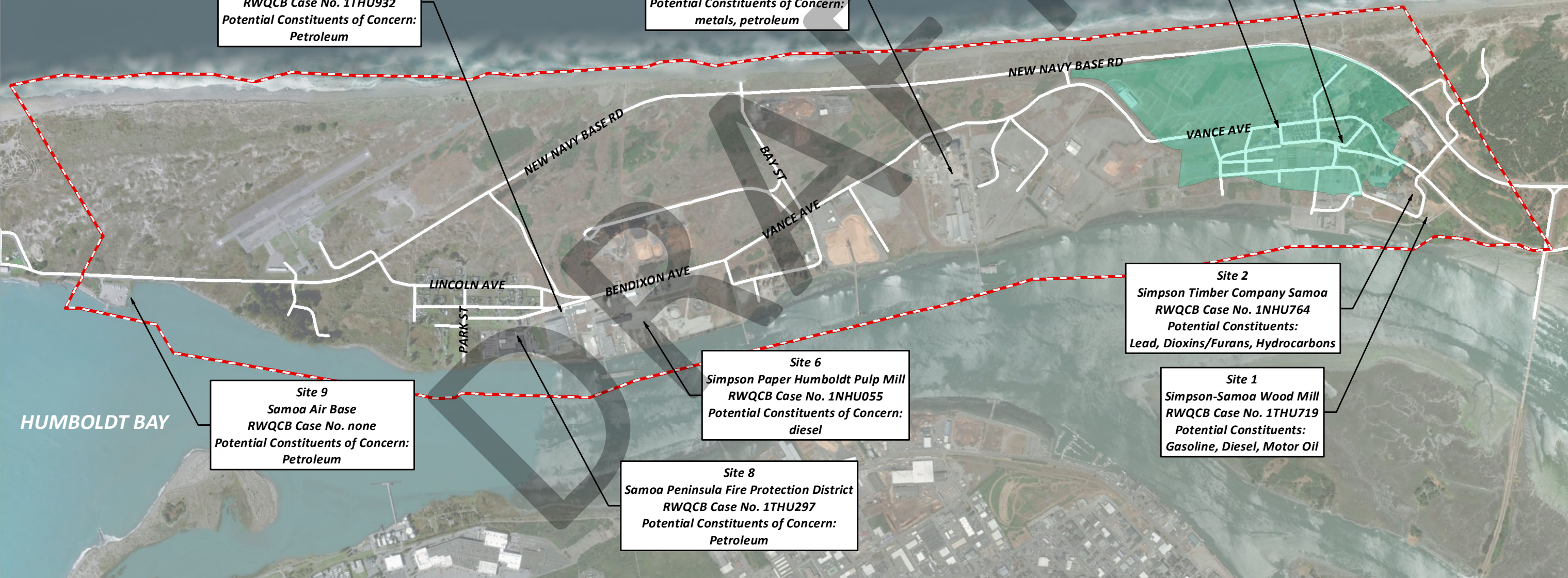

Data Sources:
 State of California GeoTracker, Humboldt Bay Harbor, Recreation & Conservation District, North Coast Regional Water Quality Control Board, and Department of the Army.

Paper Size ANSI B
 0 375 750 1,125 1,500
 Feet

Map Projection: Lambert Conformal Conic
 Horizontal Datum: North American 1983
 Grid: NAD 1983 StatePlane California I FIPS 0401 Feet



County of Humboldt
 Samoa Peninsula
 Wastewater Planning Study

Project No. SHN017203
 Revision No. -
 Date Mar 2018

**Samoa Peninsula Groundwater
 Cleanup and Monitoring Sites**

FIGURE 1.3

\\Eureka\Projects\2017012203-Samoa Peninsula Wastewater design-plan of study\002-PDR\GIS\PROJ_MXD\GHD_MXD\Fig1_3_PeninsulaPhaseI.mxd
 Print date: 08 Mar 2018 - 12:20

Data source: Source: Esri, DigitalGlobe, GeoEye, Earthstar Geographics, CNES/Airbus DS, USDA, USGS, AeroGRID, IGN, and the GIS User Community. Created by SHN: cswanson

DRAFT



- Site 3: Lorenzo's Shell (Town of Samoa)
- Site 4: Town of Samoa (numerous)
- Site 5: LP Samoa Mill (RMT-II)
- Site 6: Simpson Paper Humboldt Pulp Mill (Fairhaven Business Park)
- Site 7: Fairhaven Business Park
- Site 8: Fairhaven Fire Protection Dist (Town of Fairhaven)
- Site 9: Samoa Airbase (Samoa Boat Launch and Campground)

The Simpson Samoa Wood Mill and Simpson Timber Company Samoa are both located east of the proposed alignment. In Fairhaven, two identified sites are located more than 150 feet off of the route, and though shallow petroleum impacts have been historically reported in these areas, distance and groundwater flow directions likely reduce potential for encountering impacts related to these sites. Awareness of the potential to encounter impacts at the Fairhaven Business Park site if a lateral to the south is to be installed must be made to workers, additional information regarding distribution of soil and water impacts can be attained from Geotracker for RWQCB Case No. 1THU932 prior to the initiation of work.

Site 4 (Town of Samoa) covers a broad, ill-defined area, and will likely be relevant to workers. Documents associated with site 4 include SMCPs and/or deed restrictions for the following features:

- Lorenzo's Shell, 1 Cutten Street, Samoa (Site 3)
- Samoa Cookhouse Garage
- Hammond Power House (south of work area)
- Soccer Field Garage
- Soccer Field
- Wastewater Pond and Percolation Basin
- Railroad and Rigging Shop
- Unlined Burn Pit

Additionally, Phase I and/or Phase II reports were reviewed for the Roundhouse (Phase I and II), and Samoa Townsite (Phase II), and are included in documents downloaded during this effort. A Phase I ESA was performed on the Hammond Mill site in 2012 for the HCEC, but this document was not received as of the writing of this report, this document would likely be of value for this work, and efforts to secure it will continue. A Phase I ESA describing conditions observed at RMT-II (1 TCF Drive, Samoa; Site 5) was reviewed; the site is located on the southern boundary of Vance Avenue where dissolved phase petroleum hydrocarbon and metals impacts have been recorded in the area of the proposed route, albeit none since 2010 (LACO, 2013).

A soil management contingency plan was secured for the Simpson Fairhaven Mill site (Site 6) and should be consulted if work is to extend south into the site.

Little information was found for the Samoa Fire Protection District site in Fairhaven (Site 8, RWQCB Case No. 1THU297). An image reviewed implies that petroleum impacts were located approximately 150 feet south of Bendixsen Avenue. Unless work extends south from Bendixsen Avenue into this area, there is no interpreted threat to the health of workers or the environment (Clearwater Group, 2002).



The western-most site is described in a site report prepared by the Department of the Army for the former Air Station (Site 9). The county boat ramp and campground area is the former location of a floating plane dock and refueling area. Three large underground storage tanks (USTs) for storage of gasoline were formerly located in this area. The exact site location of these USTs is unknown, but is described as being submerged. The fate of the USTs was not described in the report, and the USTs may still be in the ground. However, assuming them to be single-wall steel tanks, based on the presumed period of operation and construction of USTs that were in use at that time, it would be assumed that corrosion of the steel by salt water would have led to degradation of the USTs and that contents would have been released long ago. Based on time elapsed, groundwater flow direction, assumed soil types and hydraulic properties, and submerging of the area by subsidence, it is assumed that any released materials would be submerged, and/or diluted/degraded by 2018 (Department of the Army, 2011).

2. Project Planning Area

2.1 Location and Development of Wastewater Service Area Boundaries

The project planning area includes areas within the proposed PCSD boundary, bound by Humboldt Bay to the east and the Pacific Ocean to the west, extending north to the Manila Community Services District (CSD) boundary and south to the federal property line that includes the Coast Guard Station and Samoa Dunes Recreation Area (Figure 1-2). Estimates for wastewater flows and loads for the federal properties to the south of the PCSD service area have been included in this report in case services to these facilities are provided in the future.

2.2 Land Use

Current land use within the PCSD service area includes a mix of residential, commercial, industrial, coastal dependent industrial, public facilities, parks, and a school (Figure 2-1). Residential areas include the communities of Samoa, Fairhaven, and Finntown. Industrial areas include two former pulp mill sites (which have been re-purposed for various commercial and industrial uses), a chip export facility with a marine terminal, a biomass power plant, and vacant industrial properties. Commercial interests include aquaculture, boat repair, potting soil manufacturing, and a recycling transfer station.

Proposed land uses in the PCSD service area vary widely because there is a significant amount of vacant industrial property and infrastructure that can be re-commissioned or re-purposed. However, most of these parcels are zoned coastal dependent industrial, restricting use to industries dependent on coastal marine access, such as, shipping or aquaculture. Existing industrial facilities may change over time; however, large industrial users meeting current zoning requirements are

| | | | |
|-----------------------------------|-----------------------------------|-------------------------|-------------------------------|
| (P) Peninsula CSD Boundary | CR - Commercial Recreation | MG - Industrial General | RS - Residential Suburban |
| County Zoning Designations | MB - Business Park | NR - Natural Resources | RM - Residential Multi-Family |
| CG - Commercial General | MC - Industrial/Coastal Dependent | PF - Public Facility | U - Unclassified |
| | | PR - Public Recreation | |



Data Disclaimer
 Proposed Samoa Peninsula Community Services District (SPCSD) boundary dependent upon Humboldt County Local Area Formation Commission (LAFCo) approval.

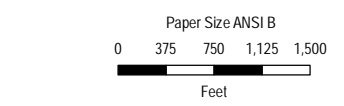

Map Projection: Lambert Conformal Conic
 Horizontal Datum: North American 1983
 Grid: NAD 1983 StatePlane California I FIPS 0401 Feet

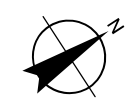

County of Humboldt
 Samoa Peninsula
 Wastewater Planning Study

Project No. 11146487
 Revision No. B
 Date February 2018

Zoning Map

FIGURE 2.1

G:\11146487\Hum Co-Samoia Pen WW Plan Study\08-GIS\Maps\Deliverables\Final\Report\F2-1_ZoningMap_Labels_revB.mxd
 Print date: 20 Mar 2018 - 10:15
 Data source: Source: Esri, DigitalGlobe, GeoEye, Earthstar Geographics, CNES/Airbus DS, USDA, USGS, AeroGRID, IGN, and the GIS User Community. Created by: ashows

DRAFT



working with the California Coastal Commission on updating the Humboldt Bay Area Plan, the county's Local Coastal Plan (LCP), to allow for a treatment plant development and collection system connection to residential areas. It is anticipated that the LCP will be updated to allow for the permitting and construction of a treatment plant by the time that any recommendations from this PER are implemented.

There is limited residential growth potential outside of the Town of Samoa due to coastal and industrial zoning, environmental habitat sensitivity, and tsunami and earthquake hazards.

2.2.1 Town of Samoa

The Town of Samoa includes a mixture of residential, commercial, industrial, natural resources, and public facilities zoning. The Town of Samoa was re-zoned in 2008 in accordance with the STMP in an approved Humboldt County LCP amendment and final master EIR (State Clearinghouse Number 2003052054). The Town of Samoa is currently home to approximately 93 residences, the Samoa Cookhouse, the Peninsula Union School (outside of the STMP), the Samoa Women's Club, the Danco cabinet shop, and the Timber Heritage Foundation Museum. The STMP includes two residential construction phases that have not received final approval, and have been in development since 2001. Phase I of the STMP includes rehabilitation of all existing, currently occupied homes (93), rehabilitation of 7 uninhabited homes, construction of 2 new homes within the existing town footprint, construction of 84 new medium-density residential units south of the existing townsite, and construction of commercial, public, industrial, and recreational facilities. The total proposed Phase I residential buildout is 186 homes. Phase II of the STMP includes 105 low-density and 62 medium-density residential units. Phase III of the STMP includes a business park.

2.2.2 Fairhaven

The town of Fairhaven is zoned RS-X, residential suburban with no further subdivision allowed (Humboldt County, 2017; Humboldt County Code, Title III, Division 1, Section 313-6.1 and 313-39.1). Construction of additional units is allowed under the current zoning, which may include additional houses or smaller accessory (guest) quarters. Fairhaven includes 208 Assessor's parcel numbers (APNs), approximately 66 residences, and the Samoa Peninsula Fire Protection District fire hall and volunteer quarters (Humboldt County, 2017). The Town of Fairhaven also has potential for development, although new construction in Fairhaven is currently restricted due to the presence of environmentally sensitive habitat areas (ESHAs) including wetlands as the cost of constructing new septic systems that comply with County requirements.

2.2.3 Finntown

Finntown is zoned MC-A, industrial/coastal dependent with an archaeological resource area (Humboldt County, 2017; Humboldt County Code, Title III, Division 1, Section 313-3.4 and 313-16.1). This type of zoning does not allow residential construction, but does allow a caretaker's quarters. It is assumed that further residential development in Finntown will not occur due to current zoning restrictions. It is possible that additional caretaker's quarters may be constructed to accommodate additional coastal dependent industrial development in Finntown; however, further development of this type is uncertain at this time. Finntown currently consists of approximately 10



homes and approximately 23 Assessor's parcels that are small enough to be accommodate a single-family residence if rezoned from coastal dependent industrial to residential.

2.2.4 Industrial Uses

The majority of the proposed PCSD service area is zoned industrial including Industrial Coastal-Dependent and Industrial General (Humboldt County, 2017). Coastal-dependent industrial areas include the DG Fairhaven Biomass Power Plant, the Fairhaven Business Park (formerly Simpson Mill), RMT-I, RMT-II (former Samoa Pulp Mill), the California Redwoods chip export facility, and the Samoa waste transfer station owned by Recology.

As part of the LCP update the County is currently evaluating coastal-dependent zoned lands to protect lands with essential access to ports and allow for broader economic use of other land. Future uses of industrial properties may include power generation, research, manufacturing, shipping, telecommunications, aquaculture and mariculture.

The HBHRCD has attempted to attract a number of industries to RMT-II with the benefit of using the existing ocean outfall for wastewater discharge. The ocean outfall is a major asset on the peninsula supporting potential commercial, industrial, and residential development opportunities. The Fairhaven Business Park (former Simpson Pulp Mill) also has an ocean outfall, although portions of the upland section are in disrepair and its southern outfall pipe was damaged in 1987 and blocked off; it was last inspected on September 30, 2015.

2.2.5 Commercial Uses

Commercial zones include the Samoa drag strip/Eureka Municipal Airport, which includes the Humboldt Bay Social Club. Across the street from the airport is the Oyster Bay Resort on a private parcel, which includes small guest cottages on a bay-front property. Areas within the Town of Samoa are zoned for commercial use in accordance with the STMP, and there is a vacant lot west of the town of Fairhaven that is zoned commercial.

2.2.6 Recreational Uses

County-maintained recreational areas include the Samoa boat ramp and campground, and public beach access areas including the two most popular: Power Poles and Bay Street.

2.2.7 Federal Property

South of the PCSD service area is federal government property including a U.S. Coast Guard Station and the Bureau of Land Management (BLM) Samoa Dunes Recreation Area. These two areas are not currently included in the proposed PCSD wastewater plan; however, wastewater flows for each are estimated in case they are added to the system in the future.

2.3 Current and Future System Users

The Town of Samoa currently has the only centralized wastewater collection and treatment system in the PCSD service area. However, nearly all of the existing facilities are to be completely replaced during the development of the town. Future users on the rest of the peninsula would result from



residential development on existing legal lots and industrial development. Existing wastewater treatment in the Town of Samoa consists of two individual regional systems: 1) the western system that serves approximately 25 homes; and 2) the eastern system that serves approximately 68 homes, the Samoa Cookhouse, a hostelry, a museum, a post office, the Danco cabinet shop, and the Women’s Club. Currently, the Peninsula Union School is proposed to remain on the existing septic system serving the school. Table 2.1 presents proposed development and sewer connections in the Town of Samoa.

Table 2-1: Proposed development and sewer connections in the Town of Samoa Master Plan (CEC, 2015).

| Phase | Description | Unit | Count | Notes |
|-------|------------------------------|-------|-------|-------------------------|
| I. | Existing Homes | House | 93 | Rehabilitation |
| | Existing Lots | House | 9 | New Construction |
| | Medium Density Residential | House | 84 | New Construction |
| | General Commercial | Lots | 9 | 7 with sewer, 2 without |
| | Public Facility | Lots | 2 | No sewer |
| | Public Recreation | Lots | 6 | No sewer |
| | Commercial Recreation | Lots | 11 | 3 with sewer, 8 without |
| | Coastal Dependent Industrial | Lots | 2 | No sewer |
| | Natural Resources | Lots | 1 | No sewer |
| II. | Low Density Residential | Lots | 105 | |
| | Medium Density Residential | House | 62 | |
| III. | Business Park | Lots | 24 | |

2.4 Population Trends

2.4.1 Town of Samoa

The 2010 US census indicated the Town of Samoa census designated place (CDP) had a total population of 258 people with an occupancy rate of approximately 2.84 persons per household (US Census Bureau, 2010). According to the STMP, the full build-out for the Town of Samoa includes 353 residences for a total population estimate of approximately 1,003 people at the 2010 occupancy rate. CEC estimated that there were 93 homes in the Town of Samoa in 2015 for a population of approximately 264 (CEC, 2015).

Samoa Peninsula Union School

The Samoa Peninsula Union School District is not included in the Town of Samoa Master Plan for development, and is proposed to remain on an individual septic system (CEC, 2015). Once PCSD assumes control of the proposed Town of Samoa collection and treatment systems, it is assumed that the school will be connected to that system. The school has a cafeteria/gymnasium with showers and a swimming pool. The school currently serves the communities of Fairhaven, Finntown, and Samoa and has approximately 39 elementary school (kindergarten to 8th grade)



students, 44 other students in 5 classrooms that are rented out, and approximately 34 staff members.

It is assumed that 1 staff member per rented classroom is associated with the other students and 29 staff members are associated with the peninsula students. The weighted average growth rate for the school is estimated to be 237% based on population growth estimates for the Towns of Samoa and Fairhaven. The full build-out student population is estimated to be 132. Once the school expands, extra classrooms may no longer be rented to outside students such that the school is assumed to only serve peninsula students. The staff population is not expected to expand proportionately with the student population, because the current student population density is assumed to be below the capacity of the existing school facilities. The staff population is assumed to increase by 10, for a total projected staff population of 39.

2.4.2 Fairhaven

The Town of Samoa CDP had the only 2010 census occupancy estimate (2.84 people per household) within the proposed PCSD service area; thus, this estimate is used for the rest of the project area as well. The community of Fairhaven currently has approximately 66 houses for a total population of approximately 187 people. The number of houses has been estimated using the Eureka Aerial 2014 imagery layer and the APN parcel boundary layer from the Humboldt County web GIS portal (Humboldt County, 2017).

Future population growth in Fairhaven will depend largely on the ability for new development within the town, which is limited by the presence of ESHAs, tsunami run-up requirements and other permitting constraints but also by the access to sanitary services. If a new centralized wastewater collection and treatment system is constructed, new construction may be expected in areas served by the new sewer system. For the purposes of this study, growth is assumed to be limited to infill of existing legal lots within currently developed areas (Figure 2-2). Extension of the collection system to serve new homes outside the infill zone is assumed to require additional planning and environmental review which would be the responsibility of a future developer.

Within the infill area there are 125 APNs; some of these parcels contain multiple homes, some homes overlap multiple parcels, one of the parcels includes a shared driveway between two homes, and some of the empty parcels appear large enough for multiple homes. Each empty single parcel is assumed able to contain one new single-family residence, current regulations would require submission of a tsunami vulnerability report, which at this time is assumed to preclude second residences on larger lots. A total of 128 homes is estimated for the full build-out in Fairhaven within the infill area with a total projected future population of 364 people.

Given that the zoning allows construction of accessory (guest) quarters as well, it is assumed that 50% of the total potential homes will construct accessory dwellings. An estimated 64 accessory dwellings are assumed for the purposes of this study. Accessory dwellings are assumed to have one bedroom with an average occupancy of 1.5 people per bedroom (USEPA, 2002) for a total accessory dwelling population of 96 people. Note that accessory dwellings are not additional single family homes and do not include a second sewer connection.

The total potential infill population for Fairhaven is 460 people. This growth estimate is assumed to occur within a 30-year planning horizon for the purposes of sizing wastewater systems. The actual

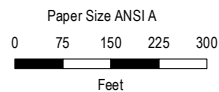
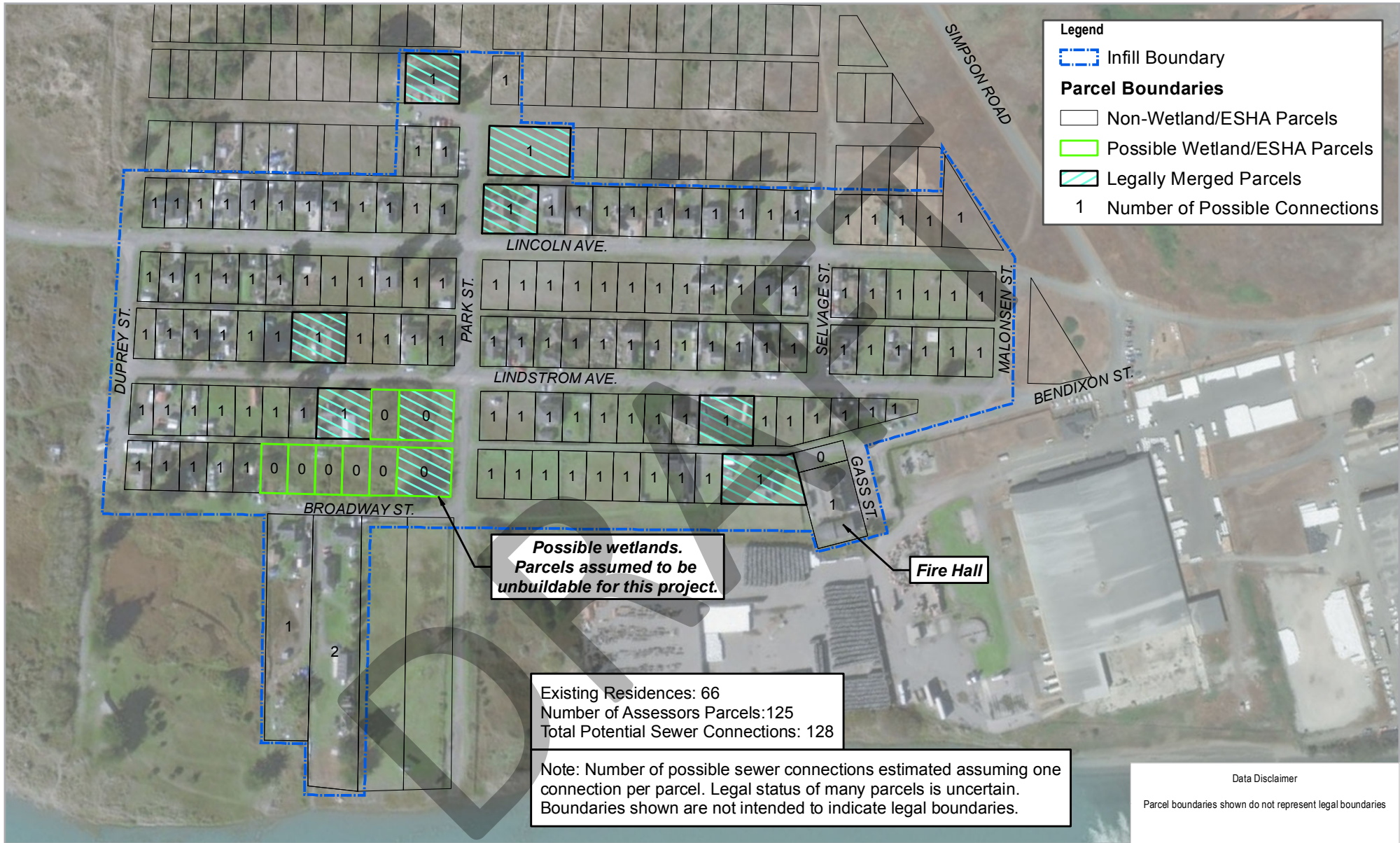

Map Projection: Lambert Conformal Conic
 Horizontal Datum: NAD 1983 2011
 Grid: NAD 1983 2011 StatePlane California I FIPS 0401 Ft US



County of Humboldt
 Samoa Peninsula
 Wastewater Planning Study

Project No. SHN017203
 Revision No. -
 Date Mar 2018

Fairhaven Parcel Count

FIGURE 2.2

DRAFT



growth and rate of growth in Fairhaven will be influenced by other factors; however, for the purposes of infrastructure design, these estimates are assumed to be conservative.

2.4.3 Finntown

Finntown currently contains approximately 10 homes for an estimated total population of 28 people. Because Finntown is zoned coastal-dependent industrial, it is assumed that no further residential development will occur.

2.4.4 Other

Other areas of the peninsula, including industrial, commercial, and public properties, are assumed to remain as such and no new residential development, outside Samoa and Fairhaven, is known at this time.

3. Existing Facilities

3.1 History

The Samoa Peninsula has historically been home to the timber and shipbuilding industries and small townsites housing workers from these industrial facilities. As the timber and shipbuilding industries waned, so too have uses of the industrial sites. Some of the industrial sites have been demolished, some lie dormant ready to be re-commissioned, and some are still in use. Residential areas that once housed mill-workers and ship-builders now include a mix of homeowners and renters from various occupations throughout the greater Humboldt Bay area.

Shipbuilding is the oldest industry on the peninsula, starting in Fairhaven with the Fay Brothers Ship Yard started circa 1850 (Clarke Museum, 2017). The famous shipbuilder Hans Bendixsen purchased the Fay Brothers Ship Yard in 1874, and this yard was later leased to the two large timber mills on the peninsula before a second ship yard was built in Samoa in 1917 (Colton, 2017). There is currently one smaller commercial boat yard near Fairhaven in the area currently known as Finntown, but the existing yard does not operate at the scale of its predecessors.

The timber industry followed closely behind shipbuilding on the peninsula with the first large lumber mill started in Samoa by John Vance Mill & Lumber Company in the 1890s. The original Samoa mill site was on what is now RMT-I. A rail line was built from Arcata to the Samoa Mill in 1893; the historic rail line now serves a small recreational crew car speeder operated by the Timber Heritage Association (Timber Heritage Association, 2018). Between 1963 and 1966, the original mill was demolished and a pulp mill was built by Georgia-Pacific on what is now RMT-II, south of the former mill site and Town of Samoa (Humboldt County, 2006). Various economic pressures caused the Samoa (or Evergreen) Pulp Mill to be shut down in 2008, and in 2013 it was purchased by the HBHRCD to conduct an environmental cleanup of the site and protect Humboldt Bay.

The second large mill site on the peninsula was located in Fairhaven, approximately 2 miles south of the Town of Samoa. This mill was built by the Simpson Timber Company in 1966 and closed in the early 1990s due to economic pressures (Spector, 1990). This site is now known as the Fairhaven Business Park.



The Samoa Fire Brigade was formed in 1902. The Fairhaven Fire District was formed in 1952. The two fire departments merged in 1994 when the Fairhaven Fire District annexed Samoa and formed the Samoa Peninsula Fire Protection District (SPFPD). The SPFPD is organized and governed by the Fire Protection District Act of 1987 (Health and Safety Code section 13800 et seq.). The SPFPD is governed by a five-member Board of Directors, elected by the district voters. The SPFPD currently provides fire protection for the southern part of the Samoa Peninsula, extending south from the vicinity of the Highway 255 Bridge to the southern tip. The SPFPD currently provides the fire/rescue services for the areas that include Fairhaven, Finntown, the industrial properties, and the Town of Samoa. This service area is identifiable as a peninsula-wide service and is not associated with any particular community or use. The main fire station is located at 1982 Gass Street in Fairhaven. A secondary station is located in The Town of Samoa on Cutten Street. The Cutten Street station is housed in what is known as the Samoa Block and is used primarily for equipment storage (SHN, 2017a).

The Samoa Pacific Group, LLC (SPG), purchased the Town of Samoa at auction in 2001. Since 2001, SPG has been pursuing the STMP for development of the town, including replacement of the existing sewer collection systems, construction of a new WWTF, and construction of a new disposal system. SPG has maintained the town infrastructure and housing since 2001, renting houses to the public, and working toward the final goal of rehabilitating the historic townsite and expanding the range of services available to residents of the peninsula.

The proposed PCSD was approved by popular vote by eligible residents of the proposed PCSD service area in the November 7, 2017 election.

3.2 Town of Samoa Wastewater Facilities

Individual on-site septic and leachfield systems, privately owned and maintained by each property owner, are used to treat municipal wastewater from all residential, commercial, and industrial properties in the PCSD service area outside the Town of Samoa. The Town of Samoa is served by two separate sewer collection, treatment, and disposal systems: the western system that serves approximately 25 homes; and the eastern system that serves the rest of the community including approximately 68 homes, the Women's Club, the Cookhouse, the hostelry, the post office, and the cabinet shop. The eastern and western systems are currently owned and operated by SPG.

There are also two ocean outfalls on the peninsula that previously served each of the former pulp mills, including the Samoa Pulp Mill (now RMT-II) and the Simpson Mill (now the Fairhaven Business Park). The ocean outfall at RMT-II is currently in use by the DG Fairhaven biomass power plant that discharges approximately 170,000 gpd when in operation, under NPDES permit R1-2012-0027; however, the outfall is operating far below its rated capacity of 40 MGD. The former Simpson pulp mill outfall is no longer in use, a portion of the upland section is in disrepair, and the southern outfall pipe has been blocked off.

3.2.1 Existing Town of Samoa Collection System

The Town of Samoa has the only centralized wastewater collection systems in the PCSD service area including the eastern and western collection systems. The eastern and western collection systems were likely constructed around 1920 and are constructed of primarily vitrified clay pipe



(VCP; CEC, 2017). The entire collection system is proposed to be replaced during Phase I of the STMP.

The eastern system includes approximately 8,800 feet of pipe, and the western system includes approximately 1,500 feet of pipe (Figure 3-1). The eastern collection system also includes three septic tanks distributed in the system: one is located at the Cookhouse, one is located downstream of the Cookhouse near N. Bay View Avenue, and the third is located at the junction between the main that serves the Cookhouse and the rest of the eastern system near the Post Office. The latter two septic tanks originally included redwood bark filters used to treat the wastewater; however, these filters fell into disrepair and are currently offline.

The Cookhouse includes a 3,000-gallon grease interceptor, a 5,000-gallon septic tank, and a 1,500-gallon pump tank. The Cookhouse pump tank pumps to a 15,000-gallon septic tank at bark filter “A” where it combines with flow from the northeastern part of town. Effluent from the 15,000-gallon tank flows by gravity to a 20,000-gallon septic tank at bark filter B.

3.2.2 Existing Town of Samoa Treatment System

The Eastern system consists of gravity sewer lines, two bark filters, pumps and pressurized force main lines, septic tanks, an equalization pond, and land disposal area. Effluent is collected in a network of septic tanks and then pumped to an infiltration pond. In its current condition the pond performs much like a free-surface wetland. Much of the infiltration area has become a forested wetland. This system was not designed to meet the standards for maintenance, reliability, and standby capabilities currently imposed by regulatory agencies. Table 3-1: Existing Town of Samoa treatment system effluent limitations (NCRWQCB, 2014). Primary treatment for the eastern system utilizes a series of septic tanks and two defunct bark filter structures. The bark filter structures contain eight to 10 individual filters located above large septic-style tanks. Each filter is made of sections of corrugated pipe six feet in diameter and three feet long, filled with redwood bark, and standing on end over a concrete pedestal. The bark filters are no longer functional because much of the bark that once filled the corrugated pipe has broken up and been washed out, and the pumps and rotating distribution pipes at the top of each filter are inoperative. Similar to septic tanks, the tanks below the bark filters collect solids and are periodically pumped out. The two tanks have a combined capacity of 40,000 gallons. The existing primary system adequately attenuates flows and produces effluent that is low in solids and that can be pumped through small diameter piping without clogging. After being collected at the last bark filter structure, all of the wastewater is pumped to the treatment wetland/pond. The 2006 Draft EIR stated that the treatment wetland/pond is approximately 25 feet wide by 100 feet long and five feet deep; however the 2015 Waste Discharge Permit submittal by CEC, stated the pond was 25-feet wide by 200-feet long, and 13-feet deep. Remote sensing of the pond using Google Earth indicates it appears to be approximately 25-feet wide and 140-feet long. Given the vegetative cover, it is also highly unlikely that the pond is 13-feet deep, and the 5-feet depth quoted in the Draft EIR is much more likely.

The soils of the pond embankments appear to be coarse gravel and sand and are completely overgrown with blackberry bushes. The surface of the pond is almost completely covered with emergent plants, primarily cat tails, and resembles a free-water surface wetland. The pond is estimated to have a capacity of 0.5 million gallons and provide about 26 days of treatment (CEC, 2002). CEC Engineering estimates that the wetland pond reduces BOD (biochemical oxygen



demand) from a level of approximately 50 mg/liter down to around 20 mg/liter. Given the presence of extensive algae growth on the pond, it is likely that the BOD does not drop significantly in the pond due to the subsequent presence of BOD introduced by the algae growth. The effluent from the pond flows into the percolation/infiltration area. Table 3-1 contains the effluent limitations from the Draft Waste Discharge Permit for the Eastern system, these limitations are much higher than the NCRWQCB would likely permit for a new wastewater treatment plant on the peninsula.

Table 3-1: Existing Town of Samoa treatment system effluent limitations (NCRWQCB, 2014).

| Parameter | Maximum Daily Value | Average Monthly Value |
|---------------------------|---------------------|-----------------------|
| Biochemical Oxygen Demand | 80 mg/L | 50 mg/L |
| Total Suspended Solids | 80 mg/L | 50 mg/L |
| Total Nitrogen as N | 15 mg/L | 10 mg/L |
| Grease and Oil | 50 mg/L | 25 mg/L |

The Western System serves approximately 25 residences located on the west side of the ridge line of the peninsula, and is a gravity flow system into a 15,000 gallon septic tank and classic leach trench system. The school system is also a gravity flow leachfield system; however, the school system will not be part of the SPG proposed upgrade project. It will continue to use the existing treatment system it is currently utilizing (CEC, 2015)

Both systems have been in operation for many decades and are in need of an upgrade in order to meet current standards for treatment and disposal (County of Humboldt, 2006). The existing systems are dilapidated and past their useful lives. It has been reported by SPG staff that there is significant infiltration and inflow into the system, especially in areas where infrastructure is located below 8 feet above mean sea level (CEC, 2015)

3.2.3 Existing Town of Samoa Disposal System

Effluent from the Eastern System’s treatment pond is conveyed into the percolation/infiltration area that is approximately 30 feet wide at the upstream end, approximately 125 feet wide at the downstream end, and approximately 750 feet long. The area is dominated by a mature stand of Hooker willow. The willow-dominated channel fans out before connecting to an herbaceous dune hollow near New Navy Base Road. See Table 3-2 for both the Eastern and Western disposal system capacities.

Table 3-2: Existing Town of Samoa treatment system flow capacity (NCRWQB, 2014).

| System | Dry Weather Flow | Wet Weather Flow |
|---------|------------------|-------------------------|
| Eastern | 17,000 gpd | 32,000 gpd |
| Western | 7,500 gpd | 7,500+ gpd ¹ |

¹ Wet weather flows were not estimated for existing Western System in CEC documents

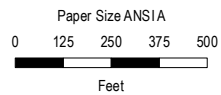
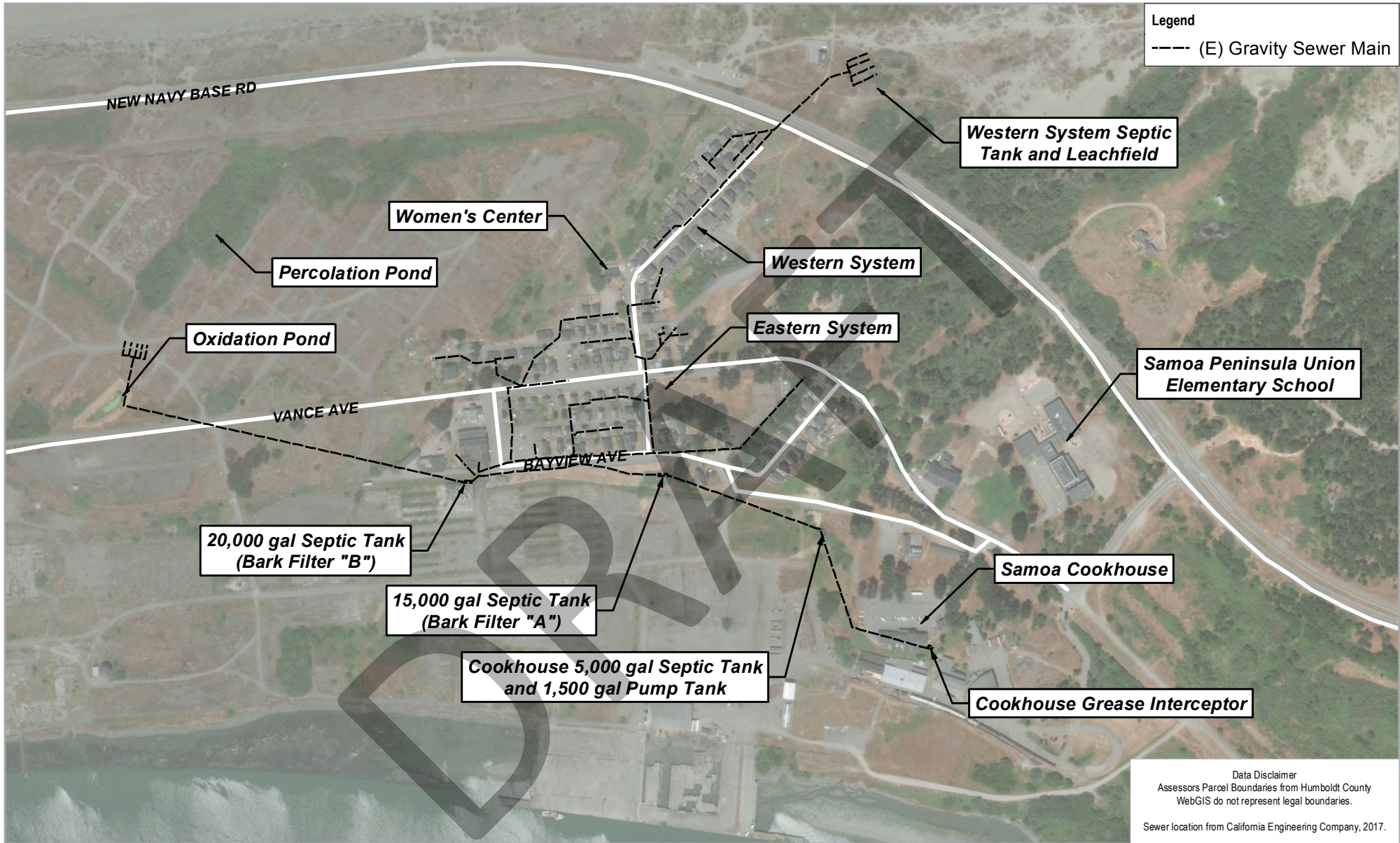

Map Projection: Lambert Conformal Conic
Horizontal Datum: NAD 1983 2011
Grid: NAD 1983 2011 StatePlane California I FIPS 0401 Ft US



County of Humboldt
Samoa Peninsula
Wastewater Planning Study

Town of Samoa
Existing Sewer System

Project No. SHN017203
Revision No. -
Date Jan 2018

FIGURE 3.1

DRAFT



It is unknown to what extent treated wastewater influences the hydrology of the dune hollows connected to this system. The herbaceous dune hollow and part of the willow dominated channel lies within a deflation plane that is distinctly lower in elevation than the artificially-flooded scrub-shrub wetland that precedes it, and is less altered and/or managed by human activity. The division between the artificially flooded “man-induced” wetland and the dune hollow wetland (which is hydrologically connected to the seasonal freshwater table) was established based primarily on elevation patterns (County of Humboldt, 2006).

3.2.4 Existing Town of Samoa Solids Handling

Since 2010, approximately 2 dry metric tons per year of biosolids has been generated at the treatment facility (SHN, 2017b). Biosolids are transferred to Steve’s Septic Service in McKinleyville where Class B pathogen removal is achieved by dewatering with polymer addition. The leachate is discharged to a municipal sewer system, and polymer sludge is transported to Anderson Landfill in Anderson, CA. Anderson Landfill is responsible for maintaining records regarding toxicity characteristic leaching procedure or the paint filter liquids test.

3.2.5 Financial Status of Existing Facilities

All residential and commercial/business properties within the communities of Fairhaven and Finntown are served through on-site, individual septic tank and leachfield systems that are the property owner’s responsibility. Active industrial properties are also served by on-site private wastewater disposal systems. Based on the current number of water meter connections, and considering existing residential, commercial, and industrial users, the estimated number of possible sewer connections for the existing area is 76.

As an area currently served by individual, on-site wastewater treatment and disposal systems, there is no existing wastewater fee associated with the Fairhaven/Finntown areas. User categories and users associated with area are:

- Residential: 76
- Industrial: 3 (Business Park, DG Fairhaven Power Plant, RMT-II)
- Institutional: 3 (Airport, County Park, CSD/Fire Dept.)

Because there is no existing public wastewater facility serving the area, at this time, there is no existing O&M cost.

There is no existing wastewater facility capital improvement plan associated with the area, and future capital improvement programming is being performed as part of this planning study.

There is no existing public wastewater facility serving the area, at this time, so there is no existing debt or reserves cost associated with the future wastewater facility.

3.2.6 Water Quality

There has been no data collected for influent wastewater quality on the Samoa Peninsula. Section 5 contains assumed influent wastewater quality used for the design purposes on this report. Table 3-1 contains the current effluent limitations for the existing Town of Samoa treatment system. These



limitations are outdated and stricter effluent limitations will be required with the development of a new treatment plant.

The nearby water resources that could be affected by wastewater on the peninsula include the Humboldt Bay, Pacific Ocean, and groundwater of which the beneficial uses per the North Coast Regional Water Quality Control Board Basin Plan (Basin Plan) are listed below.

Humboldt Bay

- industrial service supply
- navigation
- water contact recreation
- noncontact water recreation
- commercial and sport fishing
- wildlife habitat
- preservation of rare, threatened or endangered species
- marine habitat
- migration of aquatic organisms
- spawning, reproduction, and/or early development of fish
- shellfish harvesting
- estuarine habitat
- aquaculture

Pacific Ocean

- industrial service supply
- industrial process supply
- navigation
- water contact recreation
- noncontact water recreation
- commercial and sport fishing
- preservation of areas of special biological significance
- wildlife habitat
- preservation of rare, threatened, or endangered species
- marine habitat



- migration of aquatic organisms
- spawning, reproduction, and/or early development of fish
- shellfish harvesting
- aquaculture

Groundwater

- agricultural water supply
- industrial service supply
- industrial process supply

3.2.7 Planned Upgrades

There is no existing plan to upgrade wastewater facilities in the proposed PCSD service area outside the Town of Samoa. SPG is currently pursuing two possible disposal options for discharge of effluent from a new WWTF: disposal to land through a subsurface leachfield, and discharge to the ocean through the ocean outfall at RMT-II. Discharge applications for both options have been submitted to the NCRWQCB and progress of the STMP development project is currently waiting on selection and approval of a preferred discharge option by the NCRWQCB. Implementation of the STMP is currently contingent on approval by the California Coastal Commission (CCC) and the NCRWQCB of new wastewater treatment and disposal systems.

The STMP includes three proposed phases of development (CEC, 2015):

Phase I. Phase I involves upgrading the existing facilities of the town, including new wastewater collection and treatment facilities, rehabilitation of existing homes and commercial buildings, construction of new commercial and community facilities, and construction of new public recreation areas.

Phase II. Phase II will include construction of 105 new single-family residential units, and construction of 62 new medium density multi-family residential units. Wastewater facilities will be upgraded to meet the additional demand of Phase 2 uses.

Phase III. Phase III will involve construction of a new commercial business park and development of a coastal dependent industrial zone. Wastewater facilities will be upgraded to meet the additional demand of new Phase 3 uses; however, wastewater characteristics for these future uses are difficult to determine due to the uncertainty of potential users.

3.2.8 Regulatory Compliance

The Town of Samoa wastewater facilities currently operate under regulation by WDR Order R1-2001-0062 (Appendix B) and monitoring and reporting program (MRP) Order R1-2007-0026. The facilities have had 121 violations since December 2012 (NCRWQCB, 2017a). Violations include a recent leachfield failure where effluent was observed overflowing at the surface, numerous occasions of dissolved oxygen deficiencies, and numerous failures to report conditions of the western system. Notices of violation (NOV) have been submitted to SPG in 2007, 2011, 2012, and



2015, with only the most recent 2015 NOV no longer being active. None of the NOVs resulted in enforcement orders.

The DG Fairhaven biomass power plant currently operates under regulation by NPDES permit R1-2012-0027 (Appendix C). The facility has had 13 violations since February 2013 (NCRWQCB, 2017). Of the 13 violations, 4 were related to copper limit exceedances, and the rest were due to improper sample preparation, or deficient reporting. The facility has had 10 enforcement actions recorded since November 2001 with 3 still active.

3.2.9 Asset, Operation, and Maintenance Management Systems

There is no existing group or publicly owned wastewater facility in the Fairhaven/Finntown area, subsequently there are no assets and associated operation and maintenance systems. The Town of Samoa wastewater treatment facilities are privately owned and operated by SPG, such that any costs associated with these facilities are private information. Residents of the Town of Samoa pay a flat monthly fee of \$10 per household, which includes water and wastewater service.

4. Need for Project

The unincorporated communities of Fairhaven and Finntown are un-sewered. Residential wastewater systems in these areas are solely composed of individual treatment units that rely on detention and infiltration to treat and dispose of wastewater. Most of the systems are aging and are poorly suited for the soil and groundwater conditions that exist on the peninsula. Existing traditional leachfield systems are owner-maintained and are not required to be inspected by qualified professionals. Therefore, preventative maintenance is uncommon and failing systems are rarely identified until the owner or concerned party reports surfacing septage to the Humboldt County Division of Environmental Health (HCDEH). The HCDEH regulates installation of on-site wastewater treatment systems (OWTS) through a permit process, although new OWTS in Fairhaven must also obtain an ROWD from the NCRWQCB as discussed further in Section 4.1. The HCDEH have allowed Wisconsin Mound designs in repair permits for failed systems on an ongoing basis. However, HCDEH staff acknowledges that while mound systems likely prevent acute health hazards, the long-term impact to the groundwater is unknown (HCDEH, 2017). Further, the combination of environmental and geological conditions with ill-suited and failing systems has prompted the NCRWQCB to raise concerns about harmful impacts to groundwater and potential impacts to the waters of Humboldt Bay.

Although there are several vacant lots available in Fairhaven for future residential development, the lack of an adequate sewage system to protect the environment and public health is one of the limitations that restricts growth in the area.

Therefore, the proposed project will likely protect groundwater and Humboldt Bay surface water resources by reducing or eliminating these existing potential sources of impacts. The project will address environmental impacts concerns for both standard septic and mound systems, because all residential users within a specified distance of the proposed sewer main would eventually be required to abandon individual treatment systems and to connect to the regional collection system.



4.1 Regulatory Compliance Issues

Public records available from the HCDEH provided background information on sewage disposal system construction and repairs. The file information was organized by APN, and was reviewed for system failures, mound system installations, well data, system repairs, and any evidence for trends.

In 1991, the first Wisconsin mound on-site wastewater disposal system was approved by the HCDEH. At the time, Wisconsin mounds were the best available technology for leachate disposal in areas of high groundwater; however, the HCDEH and the NCRWQCB found that due to high groundwater levels and coarse sand, mound systems, while providing better treatment than standard leachfields, did not comply with the Basin Plan requirements for the Fairhaven area. The Basin Plan sets specific vertical separation requirements between disposal lines and groundwater to ensure protection of beneficial uses of the groundwater in the Samoa Peninsula.

On June 8, 1993, the NCRWQCB advised the HCDEH that no more than six mounds should be installed in the Fairhaven area until sufficient monitoring data supports permitting additional mounds. To date, groundwater monitoring for septic leachate contamination has not been completed in the Fairhaven area. Six permits were issued for new residential construction using Wisconsin mounds, the most recent being in 2006; however, an additional 14 Wisconsin mounds were permitted as emergency repairs for failed standard septic systems. In total, 20 Wisconsin mounds have been constructed with an average of one per year since 2010 as emergency replacements.

The currently installed standard septic systems are not monitored by the HCDEH; therefore, failed systems are only brought to the HCDEH's attention by owners or concerned neighbors. There is no consistent information to forecast failures of the standard systems due to a multitude of contributing factors (such as, amount of use, frequency of maintenance, and quality of initial design and construction). However, as stated previously, approximately one system per year is brought to the HCDEH's attention.

The NCRWQCB maintains the *Water Quality Control Policy for Siting, Design, Operation, and Maintenance of Onsite Wastewater Treatment Systems* (OWTS Policy). In this policy, counties are required either to accept a generic management plan that regulates on-site wastewater treatment systems (OWTS) or to create their own area-specific Local Agency Management Program (LAMP) by 2018. Due to area-specific constraints, Humboldt County has elected to develop its own LAMP, the Humboldt County OWTS Regulations and Technical Manual, replacing the county's existing on-site wastewater treatment regulations. The Humboldt LAMP regulates the installation of new or replacement OWTS under Tier 2 of the OWTS Policy. Fairhaven area is identified as having the following challenging conditions:

- Degree of vulnerability due to hydrogeological conditions
- High quality water/environmental conditions requiring enhanced protection
- Surface water vulnerable to pollution from OWTS
- Area of high OWTS density
- Parcel size susceptible to hydraulic mounding, nitrogen loading
- Multiple OWTS predating standards



Due to these issues, Fairhaven is within a Variance Prohibition Area. Variance Prohibition Areas have conditions which require special consideration to protect public health and water including high groundwater elevations, extremely coarse or restrictive soils, and high septic or water well density. Replacement of failing systems in VPAs will likely require above grade pressurized dispersal systems and new OWTS design proposals within these areas must strictly adhere to the regulations to ensure adequate treatment prior to dispersal. Variances cannot be granted for new OWTS construction. It is unlikely that site conditions found in Fairhaven would support the design of new septic system OWTS that meet the requirements of the County regulations. Any discharge to land outside the jurisdiction of the local county regulations would require review and approval by the North Coast Regional Water Quality Control Board. Additionally, proposals for future development specifically in Fairhaven are subject to submittal of a cumulative impact report that assesses groundwater mounding and organic and nitrogen impacts that are likely to result from the proposed development. The HCDEH cites Humboldt County Code section 612-2(b)(3)(j) for authority to require the report. Multiple developers have sought OWTS permits since 2006; however, no cumulative impact report has been submitted, thus no permit has been issued.

4.2 Groundwater and Surface Water Monitoring

There is little surface water on the peninsula due to coarse sandy soils and high infiltration rates. Surface water impoundments are limited to the Town of Samoa wastewater oxidation pond and percolation pond, and seasonal marshes found near Fairhaven. Seasonal marshes near Fairhaven appear due to high groundwater and low ground surface elevations in the vicinity.

Groundwater investigations on the Samoa Peninsula typically have been limited to industrial soil and groundwater contamination cleanup projects (see Section 1.1.4 above), and wastewater infiltration studies. There are no drinking water wells on the peninsula; all drinking water is supplied by the Humboldt Bay Municipal Water District (HBMWD). The following is a brief summary of groundwater monitoring data found in public records available in HCDEH APN records, the State of California Geotracker website, and information available for review on the HBHRCD website. Figure 4-1 includes the location of groundwater monitoring sites and a summary of depth-to-water data found for each site.

The subsurface investigation conducted as a part of the groundwater modeling study for the Town of Samoa anti-degradation analysis (see Section 1.1.3 above), measured depth-to-water ranging from 9.6 feet to 22.6 feet (SHN, 2015).

There has been no long-term groundwater monitoring study of Fairhaven and Finntown; however, applicants for on-site wastewater treatment systems have been required to conduct subsurface investigations to assess the suitability of mound systems on their parcels. As a requirement of the investigation, monitoring wells were installed to obtain high-groundwater levels during saturated conditions. These investigations contain data limited to between 3 and 5 measurements. From the monitoring information, depths to groundwater ranging from 0.5 feet to 5 feet were found.

In 1997 and 2010, SHN conducted groundwater studies at RMT-II (former Louisiana Pacific Pulp Mill) investigating tidal influence on groundwater near Humboldt Bay (SHN, 1998; SHN, 2011). The December 1997 study indicated that groundwater levels within 600 feet of the bay were influenced by tidal fluctuations, and the October 2010 study investigated the magnitude of the tidal influence on

PACIFIC OCEAN

- Legend
- Groundwater Monitoring Location
 - Samoa Town Master Plan Area
 - ▬ (P) Peninsula CSD Boundary

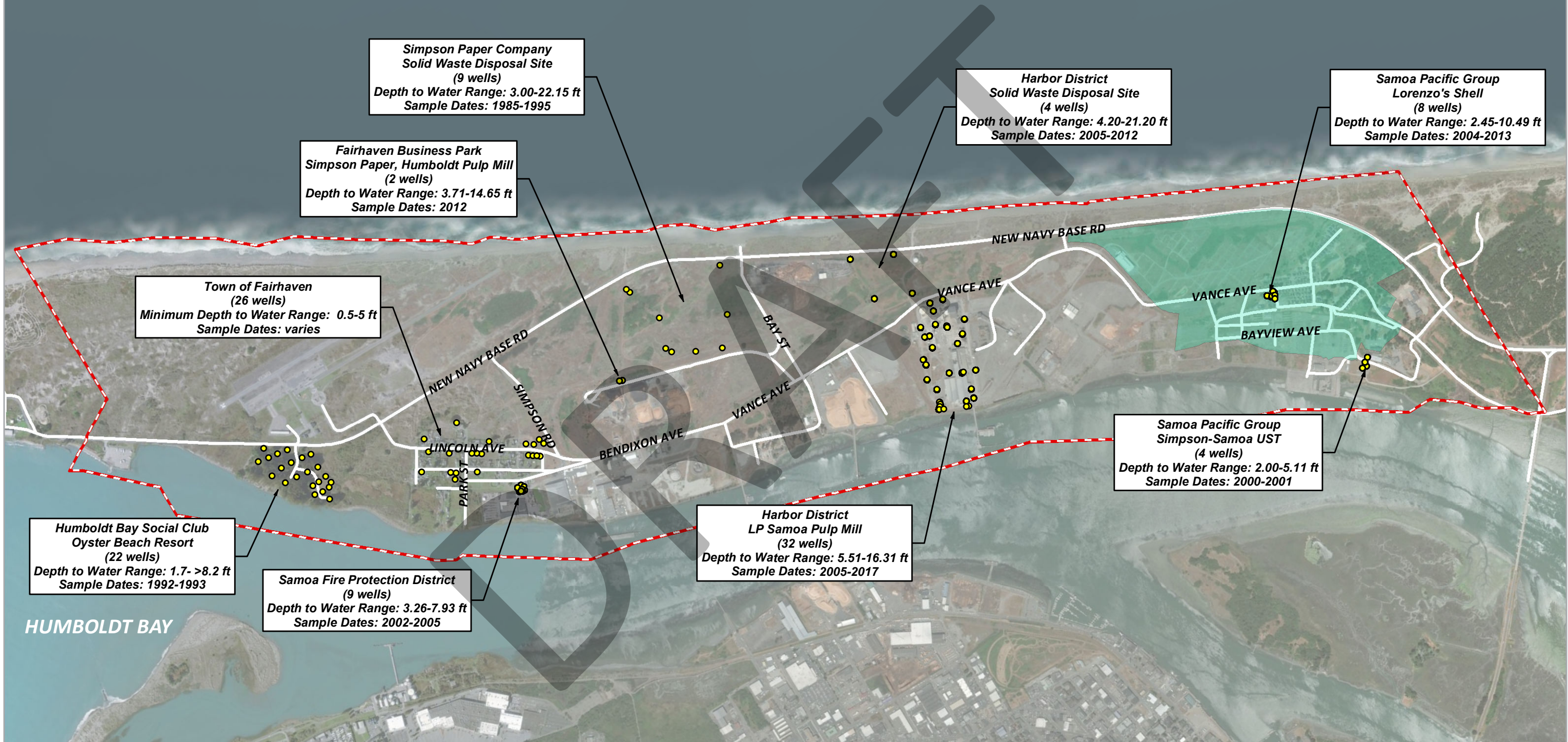

HUMBOLDT BAY

Data Disclaimer

Groundwater sampling data and locations from GeoTracker website and various SHN groundwater monitoring studies.

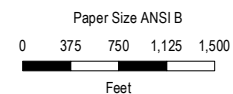

Map Projection: Lambert Conformal Conic
Horizontal Datum: North American 1983
Grid: NAD 1983 StatePlane California I FIPS 0401 Feet

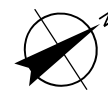

County of Humboldt
Samoa Peninsula
Wastewater Planning Study

Project No. SHN017203
Revision No. -
Date Mar 2018

Samoa Peninsula Groundwater
Monitoring Sites and Data Summary

FIGURE 4.1

DRAFT



groundwater levels near the bay. The 2010 study focused on the spring tides (tides with the greatest amplitude that occur during full and new moon phases), observing that the groundwater level in monitoring well 19 (MW-19) located approximately 450 feet from Humboldt Bay, fluctuated by less than 4 inches during the spring tides (Figure 4-2).

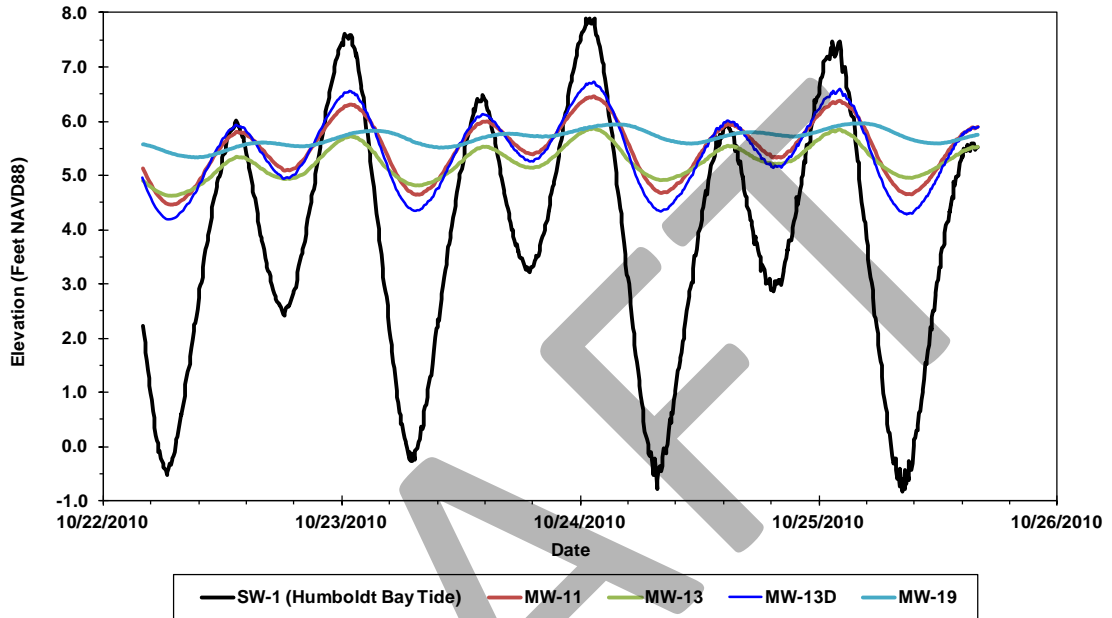

Note: MW-11, MW-13, and MW-13D are approximately 200' from Humboldt Bay, and MW-19 is approximately 450' from Humboldt Bay.
 1. SHN, 2011. Conceptual Site Model: Former Louisiana-Pacific Pulp Mill. Eureka, CA:SHN.

Figure 4-2: Tidal Study Water Elevations

4.3 Infrastructure Issues

The Town of Samoa treatment system is divided into discrete east and west systems. These systems are in poor condition and are planned to be consolidated into one new treatment facility. Maintenance of the existing systems includes repairs to the western system leachfield, pumping of the three septic tanks (two in the eastern system and one in the western system), and repairs to the collection system. The existing system is owned, operated, and maintained by SPG.

Other wastewater infrastructure in the proposed PCSD service area includes the ocean outfall that is owned and operated by the HBHRCD. This includes a 1.5-mile long, 36-inch diameter pipe with a 0.25-mile long diffuser at the downstream end. As well as the former Simpson outfall, currently owned by Security National, from the area of the Fairhaven Business Park, the condition of which is currently not operational.

5. Development of Design Flows and Loads

Wastewater flow rates and pollutant loads are used to size collection, conveyance, treatment, and disposal systems. Where existing facilities do not exist, flow rates are estimated using reference values for typical wastewater services, including pollutant concentrations and mass loads. Industrial process water flow rates and water quality characteristics are discussed and quantified where data



are available; however, it is assumed that these waters will be conveyed and treated separately from municipal and commercial wastewater on the peninsula.

Potential wastewater system users on the peninsula have been grouped according to town site, industrial property, commercial property, or recreation area. Users outside of the proposed PCSD service area have also been included in this assessment in consideration of the potential that they will be serviced by the system; this includes the US Coast Guard Station and the Bureau of Land Management (BLM) Samoa Dunes Recreation Area to the south of the service district boundary.

The Town of Samoa currently plans to construct its own wastewater treatment plant (WWTP) and sanitary sewer collection system (SSCS), so flows for the Town of Samoa have been summarized separately. Industrial users (such as, DG Fairhaven Power, the Fairhaven Business Park, the California Redwood chip export facility, the Recology recycling center, and the Redwood Marine Terminals I and II) will generate municipal wastewater from employees in addition to industrial process waters. Existing and proposed industrial process waters are listed here to the extent that they are known; however, they are assumed to require separate conveyance and treatment, and so are treated individually:

- Samoa Townsite
- Fairhaven Townsite
- Finntown Townsite
- Humboldt Bay Social Club
- Samoa drag strip
- Samoa boat ramp and RV park
- Power Poles beach access recreation area
- Bay Street beach access recreation area
- BLM Samoa Dunes Recreation Area
- US Coast Guard Station
- RMT-I
- RMT-II
- DG Fairhaven biomass power plant
- California Redwoods chip export facility
- Fairhaven Business Park
- Recology Recycling Center
- Samoa Peninsula Union School

5.1 Design Flow Definitions

Design flow rates are defined as follows:

- **Minimum Daily Flow**
Minimum flow rates are required for designing sewer pipe slopes to maintain minimum velocity to prevent settling and accumulation of solids in the collection and conveyance system. A typical minimum daily flow rate can be estimated by applying a factor of 0.3 to the average daily flow (Metcalf and Eddy, 2014).
- **Base Sanitary Flow (BSF)**
Typical sanitary wastewater flow rates have been assumed from reference values to estimate design BSF rates. BSF includes municipal wastewater flows and does not include contributions from commercial, industrial, or inflow and infiltration (I/I) sources. Based on



the assumption that the community may reach full build-out potential within the 30-year WWTP design horizon, the community is projected to produce maximum BSF at 30 years. The community is not expected to grow beyond this limit due to the potential for limited development in the coastal zone. Thus the 75-year BSF does not change.

- **Average Dry Weather Flow (ADWF)**
The ADWF is estimated as the typical flow rate during the dry months of May through October, including base sanitary flow and base I/I.
- **Average Daily Flow (ADF)**
The ADF represents the annual average daily flow rate, including base sanitary flow and an average of the dry and wet weather I/I estimates. The ADF is calculated here as the average of the ADWF and AWWF.
- **Average Wet Weather Flow (AWWF)**
The AWWF represents the average daily flow during the wet months of November through April including base sanitary flow and wet weather I/I.
- **Peak Month Flow (PMF)**
The PMF represents the peak sustained monthly flow, or the flow rate with a recurrence frequency of 30 days in 365 (91.8% chance of recurrence).
- **Peak Week Flow (PWF)**
The PWF represents the peak sustained weekly flow, or the flow rate with a recurrence frequency of 7 days in 365 (98.1% chance of recurrence).
- **Peak Day Flow (PDF)**
The PDF represents the peak sustained daily flow, or the flow rate with a recurrence frequency of 1 day in 365 (99.7% chance of recurrence).
- **Peak Hour Flow (PHF)**
The PHF represents the peak sustained hourly flow, or the flow rate with a recurrence frequency of 1 hour in 365 days (99.99% chance of recurrence).

5.2 Industrial Flows

There are currently two industrial process water dischargers on the peninsula:

- Taylor Mariculture at RMT-II
- DG Fairhaven biomass power plant

Taylor Mariculture rears oyster spat² at RMT-II and discharges approximately 2,400 gallons per day (gpd) of saltwater to an on-site septic tank and leachfield system (SHN, 2016). When operational, DG Fairhaven Power discharges approximately 170,000 gpd of fresh water (used for cooling,

2 **Oyster spat:** Once oyster larvae attach to a surface, such as other oyster shells, they are known as spat. As generation after generation of spat grow into adult oysters, they form dense clusters known as oyster reefs or beds.



cleaning, and blowdown processes) to the ocean outfall at RMT-II through manhole #5 under existing National Pollutant Discharge Elimination System (NPDES) Permit No. CA 0024571.

The HBHRCD has been trying to bring other industrial users to RMT-II and is currently in negotiations with another aquaculture company that would potentially discharge 288,000 gpd of saltwater used for rearing sablefish (SHN, 2017a). The exact quantity and quality of process water from this proposed facility is unknown at this time; however, it is assumed that this water will receive pre-treatment before being discharged directly to the ocean outfall at RMT-II through manhole #5, under a separate NPDES permit.

There is a significant amount of decommissioned or dormant industrial infrastructure on the peninsula capable of supporting additional industrial and/or commercial users. The ocean outfall at RMT-II was recently classified as having a discharge capacity of up to 40 million gallons per day (MGD), leaving a significant amount of hydraulic capacity for additional wastewater discharges (SHN, 2016).

5.3 Equivalent and Accessory Dwelling Units

Wastewater generators are not all equivalent with respect to the volume generated per unit. Units vary from individuals, to households, to bathrooms, to individual appliances (such as, faucets and washing machines). In order to be able to compare all users on a common basis, an equivalent dwelling unit (EDU) is defined as the volume of wastewater generated by an average household on an average day. Wastewater flows from other types of users are divided by the flow per EDU to determine the number of EDUs that can be used to represent that type of user. This forms a basis for establishing a fee structure on the number of EDUs represented by each user, including commercial, institutional, recreational, industrial, and residential users.

Typical residential wastewater flow rates per person are estimated by assuming 80% of potable water use is converted to wastewater. Metcalf & Eddy (2014) indicate that in regions where little water is used for landscape irrigation (such as, in the Northern California coastal region) up to 90% of potable water can become wastewater. This also accounts for urban regions where people live in high-rise apartment buildings, which do not exist in Humboldt County. Therefore a lower percent of water use is applied to local water consumption data to determine typical wastewater production rates.

The 2020 target water use rate for the City of Eureka (City of Eureka, 2016) is 108 gallons per capita per day (gpcd), and assumes 80% is converted to wastewater; typical wastewater production is estimated to be 86 gpcd. It should be noted that this target was met by the City of Eureka in 2015. With an average residential occupancy in Samoa of 2.84 people per household, the average wastewater flow per residence is estimated to be approximately 244 gpd/EDU.

Accessory dwelling units (ADUs) are small dwelling units on a residential property typically containing one bedroom. ADUs may include a small unit separate from the main house, a unit attached to the main house, or an apartment style unit above a garage. Typical maximum residential occupancy rates are 2 people per bedroom with an average of 1.5 people per bedroom (EPA, 2002). ADUs are assumed to include 1.5 people per ADU for the purposes of estimated



wastewater flow rates in this study. Using typical per capita flow rates described above of 86 gpcd, the typical flow per ADU would be approximately 129 gpd/ADU.

5.4 Base Sanitary Flows

Table 5.1 includes a list of wastewater users by type, base sanitary flow rates, and the number of associated EDUs for each user type. Users include existing and proposed sources of residential, commercial, recreational, and institutional wastewater flows. Town of Samoa phased development are assumed to occur in accordance with California Engineering Company projections (CEC, 2015; Appendix D), but flow rates per user type for Town of Samoa estimated using Metcalf & Eddy (2014) in Table 5.1 differ from CEC (2015) unit flow rates.

Table 5.2 includes a list of the other wastewater producers on the peninsula, including recreational properties not included in the scope of this planning study, industrial process water flows that will be treated and routed separately from the municipal system, and federal properties outside the jurisdiction of the PCSD.

Table 5.3 includes a summary of total base sanitary wastewater flow rates for existing and proposed users in the PCSD service area by user class including residential, commercial, recreational, and institutional users.

Table 5.4 includes a summary of base sanitary wastewater flow rates for the Town of Samoa for existing and proposed users according to the STMP. Flow projections were estimated using the proposed development as defined by CEC (2015).

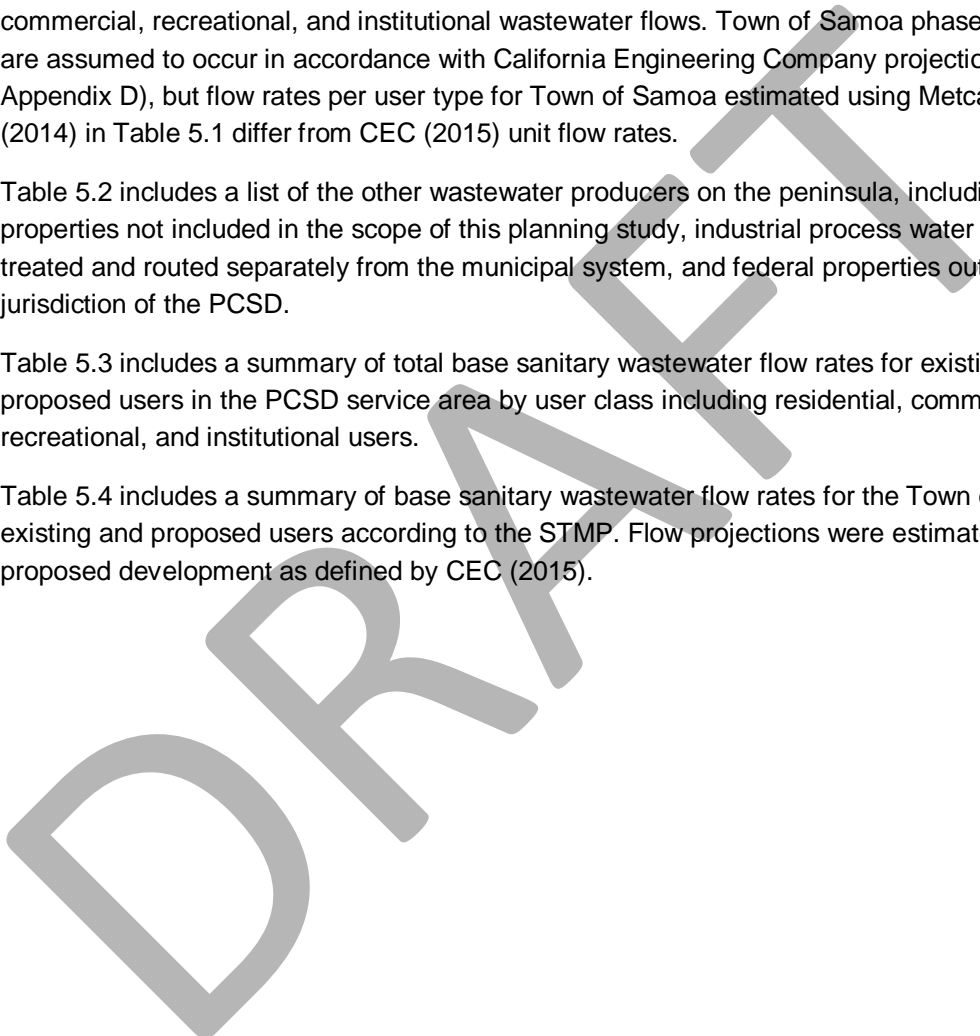



DRAFT

Table 5-1: Estimated base sanitary wastewater users and flow rates for existing and proposed facilities in the PCSD service area.

| User Class | User Description | User Type | Unit | Count | Existing/ Proposed | gpd ¹ / unit | gpd | EDU ² | Ref | Notes and Assumptions |
|---|---|--|--------------|--------|-----------------------|----------------------------|--------|------------------|-------|--|
| Residential | Fairhaven Townsite-Existing | Residential | EDU | 66 | E | 244 | 16,104 | 66 | 1,2 | Includes all currently developed lots; legal status of many lots is undetermined |
| | Fairhaven Townsite-Proposed | Residential | EDU | 62 | P | 244 | 15,128 | 62 | 1,2 | Includes currently undeveloped infill lots excluding possible wetland/ESHA lots; legal status of many lots is undetermined |
| | Fairhaven Townsite-Proposed | Residential- Accessory | ADU | 64 | P | 129 | 8,256 | 34 | 1,2,3 | Assume 50% of all homes will add an accessory dwelling unit |
| | Finntown Townsite-Existing | Residential | EDU | 10 | E | 244 | 2,440 | 10 | 1,2 | includes all developed lots; legal status undetermined |
| | Town of Samoa -Currently Inhabited Homes | Residential | EDU | 93 | E | 244 | 22,692 | 93 | 4 | Existing inhabited homes only |
| | Town of Samoa -Phase I Homes | Residential | EDU | 93 | P | 244 | 22,692 | 93 | 4 | Phase I new construction only (excluding existing inhabited homes) |
| | Town of Samoa -Phase II Homes | Residential | EDU | 167 | P | 244 | 40,748 | 167 | 4 | Phase II new construction only (excluding Phase I and existing homes) |
| | Commercial | Humboldt Bay Social Club: Oyster Beach Resort | Cabin Resort | Person | 18 | E | 30 | 540 | 2.2 | 1,5 |
| Humboldt Bay Social Club: Oyster Beach Resort | | Laundry | Load | 2 | E | 38 | 76 | 0.3 | 1,5 | 1 washer/dryer in 1 cabin unit; assumed 1 washer/dryer in main Ranch House; assumed 2 washes per day total |
| Humboldt Bay Social Club: Oyster Beach Resort | | Picnic Park w/ flush toilets | Person | 200 | E | 3.8 | 760 | 3.1 | 1,6 | special events |
| Humboldt Bay Social Club: Oyster Beach Resort | | Hotel | Employee | 0.5 | E | 8 | 4 | 0.02 | 1,7 | 1 employee every other day |
| Humboldt Bay Social Club: Samoa Field | | Hotel | Employee | 0.5 | E | 8 | 4 | 0.02 | 1,7 | 1 employee every other day |
| Humboldt Bay Social Club: Samoa Field | | Hotel | Guest | 10 | E | 53 | 530 | 2.2 | 1,5 | Samoa Field motel rooms have no kitchens |
| Humboldt Bay Social Club: Samoa Field | | Bar | Seat | 20 | E | 11 | 220 | 0.9 | 1,5 | Assume occupancy of 20 |
| Humboldt Bay Social Club: Samoa Field | | Bar | Employee | 1 | E | 10 | 10 | 0.04 | 1,7 | |
| Humboldt Bay Social Club: Samoa Field | | Food Prep | Food Prep | 1 | E | 300 | 300 | 1.2 | 6 | |
| Finntown: Live2Dive dive shop | | Department Store | Employee | 2 | E | 8 | 16 | 0.1 | 1 | Assume 2 employees |
| Finntown: Live2Dive dive shop | | Department Store | Toilet Room | 1 | E | 300 | 300 | 1.2 | 1 | Assume 1 bathroom |
| Finntown: Boat Yard | | Industrial Building | Employee | 10 | E | 15 | 150 | 0.6 | 1,8 | |
| Fairhaven Business Park: FoxFarm Soil & Fertilizer | | Industrial Building | Employee | 72 | E | 15 | 1,080 | 4.4 | 1,9 | |
| Fairhaven Business Park: Hog Island | | Industrial Building | Employee | 6 | E | 15 | 90 | 0.4 | 1,9 | |
| Fairhaven Business Park: Western Web Publishing | | Industrial Building | Employee | 19 | E | 15 | 285 | 1.2 | 1,9 | |
| Fairhaven Business Park: Sunlight Supply | | Industrial Building | Employee | 23 | E | 15 | 345 | 1.4 | 1,9 | |
| Fairhaven Business Park: Empty Office Space | | Office | Employee | 23 | P | 10 | 230 | 0.9 | 1,9 | |
| Fairhaven Business Park: Additional capacity | | Industrial Building | Employee | 100 | P | 15 | 1,500 | 6.1 | 1,9 | Assume 100 potential additional industrial jobs |
| DG Fairhaven | Industrial Building | Employee | 20 | E | 15 | 300 | 1.2 | 1,8 | | |
| California Redwoods Chip Export Facility | Industrial Building | Employee | 20 | E | 15 | 300 | 1.2 | 1,8 | | |
| RMT-I: Hag Fish | Industrial Building | Employee | 4 | E | 15 | 60 | 0.2 | 1,10 | | |



| User Class | User Description | User Type | Unit | Count | Existing/ Proposed | gpd'/ unit | gpd | EDU ² | Ref | Notes and Assumptions |
|---------------------|--|--|----------|-------|-----------------------|---------------|-------|------------------|------|--|
| | RMT-I: Crab Fisherman | Industrial Building | Employee | 20 | E | 15 | 300 | 1.2 | 1,10 | |
| | RMT-I: Small boat port | Industrial Building | Employee | 20 | E | 15 | 300 | 1.2 | 1,10 | |
| | RMT-I: Light industry shipping | Industrial Building | Employee | 30 | E | 15 | 450 | 1.8 | 1,10 | |
| | RMT-II: Taylor Mariculture | Industrial Building | Employee | 8 | E | 15 | 120 | 0.5 | 1,10 | |
| | RMT-II: Efficiency | Industrial Building | Employee | 6 | E | 15 | 90 | 0.4 | 1,10 | |
| | RMT-II: Veggie Guy | Industrial Building | Employee | 3 | E | 15 | 45 | 0.2 | 1,10 | |
| | RMT-II: Ontrac | Industrial Building | Employee | 20 | E | 15 | 300 | 1.2 | 1,10 | |
| | RMT-II: An/Elec | Industrial Building | Employee | 6 | E | 15 | 90 | 0.4 | 1,10 | |
| | RMT-II: Pacific Flake | Industrial Building | Employee | 2 | E | 15 | 30 | 0.1 | 1,10 | |
| | RMT-II: Coast Bus | Industrial Building | Employee | 4 | E | 15 | 60 | 0.2 | 1,10 | |
| | RMT-II: AHC | Industrial Building | Employee | 2 | E | 15 | 30 | 0.1 | 1,10 | |
| | RMT-II: Glass House | Industrial Building | Employee | 25 | E | 15 | 375 | 1.5 | 1,10 | |
| | RMT-II: Schneider | Industrial Building | Employee | 2 | E | 15 | 30 | 0.1 | 1,10 | |
| | RMT-II: Rouge | Industrial Building | Employee | 4 | E | 15 | 60 | 0.2 | 1,10 | |
| | RMT-II: Red Electric | Industrial Building | Employee | 4 | E | 15 | 60 | 0.2 | 1,10 | |
| | RMT-II: University Research Project | Industrial Building | Employee | 4 | E | 15 | 60 | 0.2 | 1,10 | |
| | RMT-II: Harbor District Staff | Industrial Building | Employee | 4 | E | 15 | 60 | 0.2 | 1,10 | |
| | RMT-II: Coast Seafoods | Industrial Building | Employee | 70 | P | 15 | 1,050 | 4.3 | 1,10 | |
| | RMT-II: ABC | Industrial Building | Employee | 4 | P | 15 | 60 | 0.2 | 1,10 | |
| | RMT-II: Other | Industrial Building | Employee | 60 | P | 15 | 900 | 3.7 | 1,10 | |
| | Recology Samoa | Industrial Building | Employee | 30 | E | 15 | 450 | 1.8 | 1,11 | |
| | Town of Samoa -Cookhouse | Restaurant (with toilet) | Customer | 100 | E | 6 | 600 | 2.5 | 1,4 | |
| | Town of Samoa -Cookhouse | Bar/Cocktail Lounge | Employee | 3 | E | 10 | 30 | 0.1 | 1 | Assume average 3 employees per day |
| | Town of Samoa -Hostelry | Motel (with kitchen) | Guest | 22 | E | 38 | 836 | 3.4 | 1,4 | 11 beds, 2 people per bed max. occupancy (CEC, 2015) |
| | Town of Samoa -Hostelry | Hotel | Employee | 2 | E | 8 | 16 | 0.1 | 1,4 | |
| | Town of Samoa -Women's Club | Assembly Hall | Guest | 21 | E | 2.3 | 48 | 0.2 | 1,4 | 75 person capacity, assume filled twice per week, average 21 people per day |
| | Town of Samoa -Phase I Commercial General | Store, Resort | Customer | 70 | P | 3 | 210 | 0.9 | 3,4 | 7 lots, 10 customers per lot per day, 70 total customers per day (CEC, 2015) |
| | Town of Samoa -Phase I Commercial General | Office | Employee | 14 | P | 10 | 140 | 0.6 | 1,4 | 7 lots, 2 employees each, total 14 employees (CEC, 2015) |
| | Town of Samoa -Phase I Commercial Recreation | Commercial Recreation | Lot | 3 | P | 135 | 405 | 1.7 | 4 | |
| | Town of Samoa -Phase III Commercial Park | Commercial General | Lot | 24 | P | 300 | 7,200 | 30 | 4 | Phase III build-out only (excluding Phase I, II, and existing homes) |
| Recreational | Samoa Drag Strip | Fairground | Visitor | 500 | E | 1.5 | 750 | 3.1 | 1,8 | |
| | Samoa Boat Ramp/Campground-RV sites | RV Park with comfort station | Vehicle | 13 | E | 33.8 | 439 | 1.8 | 1,12 | |
| | Samoa Boat Ramp/Campground-tent sites | Camp with central toilet and bath facilities | Person | 50 | E | 33.8 | 1,690 | 7 | 1,12 | Assume 2 people per camp site. Currently has coin-operated shower and bathroom |



| User Class | User Description | User Type | Unit | Count | Existing/ Proposed | gpd ¹ / unit | gpd | EDU ² | Ref | Notes and Assumptions |
|----------------------|---|---|----------|-------|-----------------------|----------------------------|-------|------------------|------|--|
| | Samoa Boat Ramp/Campground-day use | Picnic Park w/ flush toilets | Guest | 52 | E | 3.8 | 198 | 0.8 | 1 | Assume 2 people per trailer parking space (assumed 16 trailer spaces) |
| Institutional | Fairhaven: Samoa Fire Protection District | Residential | Person | 2 | E | 86 | 172 | 0.7 | 1 | Assume 2 personnel present at one time. |
| | Town of Samoa-Museum | Visitor Center | Visitor | 5 | E | 2.5 | 13 | 0.1 | 1,4 | Assume average 5 visitors per day (open 3-5 days/week) |
| | Town of Samoa-Museum | Office | Employee | 2 | E | 10 | 20 | 0.1 | 1,4 | |
| | Town of Samoa-Post Office | Institutions other than hospitals | Employee | 2 | E | 7.5 | 15 | 0.1 | 1,4 | |
| | Samoa Union School | School, day, with cafeteria, gym, and showers | Student | 83 | E | 19 | 1,577 | 6.5 | 1,13 | School term is typically 180 days between August and May |
| | Samoa Union School | Office | Employee | 34 | E | 10 | 340 | 1.4 | 1,13 | School term is typically 180 days between August and May |
| | Samoa Union School | Swimming Pool | Customer | 59 | E | 6.8 | 398 | 1.6 | 1,13 | Assume 50% of the total population uses the pool each day |
| | Samoa Union School | School, day, with cafeteria, gym, and showers | Student | 93 | P | 19 | 1,759 | 7 | 1,13 | Assume student population increases proportionally to residential population |
| | Samoa Union School | Office | Employee | 10 | P | 10 | 100 | 0.4 | 1,13 | Assume staff population increases by 10 |
| | Samoa Union School | Swimming Pool | Customer | 51 | P | 6.8 | 349 | 1.4 | 1,13 | Assume 50% of the total population uses the pool each day |

Notes:
 1. gpd: gallons per day
 2. EDU: equivalent dwelling unit
 3. ADU: accessory dwelling unit

- References:
1. Wastewater flow rates from: Metcalf & Eddy, 2014. Wastewater Engineering Treatment and Resource Recovery. 5th Ed.
 2. Humboldt County Website. <http://webgis.co.humboldt.ca.us/HCEGIS2.0/>. Accessed 11/20/2017
 3. USEPA, 2002. Onsite Wastewater Treatment Systems Manual. EPA/625/R-00/008.
 4. California Engineering Company, September 2015. Application/Report of Waste Discharge - Town of Samoa - 4th Submittal. Yuba City:CEC
 5. Humboldt Bay Social Club Website. <https://www.humboldtbaysocialclub.com/>. Accessed 11/11/17
 6. Personal Communication: Robert Holmlund, Director of Development Services, City of Eureka, October 11, 2017.
 7. Personal Communication: Jon O'Conner, Humboldt Bay Social Club, November 27, 2017.
 8. GHD, October 31, 2017. Personal communication with Richela Maeda. Excerpts from Tsunami Preparedness Planning.
 9. Personal Communication: Tim Callison, Security National, November 20, 2017.
 10. Personal Communication: Alan Bobillot, HBHRCD, November 14, 2017.
 11. Personal Communication: Brian Sollom, Recology, November 27, 2017.
 12. Humboldt County Website. <http://www.humboldt.gov.org/Facilities/Facility/Details/Samoa-Boat-Ramp-9>. accessed 11/14/17
 13. Personal Communication: Kathy Anderson, Peninsula Union School District, December 1, 2017.

Table 5-2: Estimated wastewater users and flow rates for existing and proposed facilities on the Samoa peninsula including recreational, industrial, and federal properties not included in Table 5.1 above.

| User Class | User Description | User Type | Unit | Count | Existing/ Proposed | gal/unit/d ¹ | gpd ² | EDU ³ | Ref | Notes and Assumptions |
|---------------------|---------------------------------|---|---------|-------|-----------------------|-------------------------|------------------|------------------|-----|---|
| Recreational | Bay Street Beach Access | Picnic Park w/ flush toilets | Guest | 40 | P | 3.8 | 152 | 1 | 1,2 | Assume 20 parking spots with 2 people per car. Currently no bathrooms |
| | Power Poles Beach Access | Picnic Park w/ flush toilets | Guest | 40 | P | 3.8 | 152 | 1 | 1 | Assumed 20 parking spots with 2 people per spot. Currently no bathrooms |
| Industrial | RMT-II: Taylor Mariculture | Industrial | Process | 1 | E | 2,400 | 2,400 | 10 | 3 | Saltwater discharge from oyster spat rearing |
| | RMT-II: Perciformes | Industrial | Process | 1 | P | 288,000 | 288,000 | 1,180 | 4 | Proposed. Saltwater discharge from sable fish rearing |
| | DG Fairhaven | Industrial | Process | 1 | E | 170,000 | 170,000 | 697 | 3 | Biomass power plant cooling water |
| Federal | Coast Guard Station | Residential | Person | 60 | E | 86 | 5,160 | 21 | 1,2 | |
| | BLM Samoa Dunes Recreation Area | Picnic Park w/ flush toilets | Guest | 250 | P | 3.8 | 950 | 4 | 1,2 | Currently has pit toilets |
| Notes: | | 1. gal/unit/d: gallons per unit per day 2. gpd: gallons per day 3. EDU: equivalent dwelling unit | | | | | | | | |
| References: | | 1. Wastewater flow rates from: Metcalf & Eddy, 2014. Wastewater Engineering Treatment and Resource Recovery. 5th Ed. 2. Personal Communication: Jon O'Conner, Humboldt Bay Social Club, November 27, 2017. 3. SHN, 2016. Infrastructure Needs and Reuse on the Samoa Peninsula. 4. Personal Communication: Christopher Manley, Perciformes Group LLC, October 3, 2017. | | | | | | | | |

DRAFT



Table 5-3: Estimated base sanitary wastewater flow rates for existing and proposed users in the Peninsula Community Services District service area according to user class¹.

| User Class | Existing Users (gpd ²) | Proposed Users (gpd) | Total (gpd) |
|---------------|------------------------------------|----------------------|----------------|
| Residential | 41,236 | 86,824 | 128,060 |
| Commercial | 9,810 | 11,695 | 21,505 |
| Recreational | 3,077 | 0 | 3,077 |
| Institutional | 2,534 | 2,207 | 4,742 |
| Total | 56,657 | 100,726 | 157,384 |

1. Individual user flow rates estimated previously in Table 5.1.
 2. gpd: gallons per day

Table 5-4: Estimated base sanitary wastewater flow rates for existing and proposed users in the Town of Samoa, according to STMP Phase¹.

| User Class | Existing Users (gpd ²) | Phase I (gpd) | Phase II (gpd) | Phase III (gpd) | Total (gpd) |
|---------------|------------------------------------|---------------|----------------------|-----------------|---------------|
| Residential | 22,692 | 22,692 | 40,748 | 0 | 86,132 |
| Commercial | 1,530 | 350 | 0 | 7,200 | 9,080 |
| Recreational | 0 | 0 | 0 | 0 | 0 |
| Institutional | 2,362 | 0 | 1,361 ⁽³⁾ | 0 | 3,723 |
| Total | 26,584 | 23,042 | 42,109 | 7,200 | 98,935 |

1. Samoa Town Master Plan phasing as defined by: California Engineering Company, 2015. Application/Report of Waste Discharge - Town of Samoa - 4th Submittal. Yuba City:CEC
 2. gpd: gallons per day
 3. Samoa Peninsula Union Elementary School flow increase resulting from Phase I and Phase II development in the Town of Samoa only; approximately 60% of the total projected population growth in the PCSD service area occurs in the Town of Samoa.

Table 5-5: Estimated EDUs¹ for existing and proposed users in the Peninsula Community Services District service area according to user class².

| User Class | Existing Users (EDU) | Proposed Users (EDU) | Total (EDU) |
|---------------|----------------------|----------------------|-------------|
| Residential | 169 | 356 | 525 |
| Commercial | 40 | 48 | 88 |
| Recreational | 13 | 0 | 13 |
| Institutional | 10 | 9 | 19 |
| Total | 232 | 413 | 645 |

1. EDU: equivalent dwelling unit; defined as 244 gallons per day per EDU at 2.84 people per EDU.
 2. Individual user flow rates estimated previously in Table 5.1.



5.5 Peaking Factors

Peak flow rates for small wastewater systems are typically more pronounced relative to the ADF than for larger systems, because the diversity of users is less and the physical capacity of the system to equalize flow rates is less. Peaking factors are also affected by seasonal I/I into a sewer system, which increases with rainfall. Because the entire sewer system will be new, peaking factors estimated from existing flow data from nearby municipalities with aging clay pipe sewer systems would likely over-estimate peak flows, therefore reference values for average peaking factors are used here. It should be noted that reference values for peaking factors are based on historical data from existing sewer systems constructed of older materials and will likely over-estimate peak flows for a newly constructed sewer system. However, reference values include surveys of systems in many climatologic regions, and of varying construction materials and condition, such that the average values presented in literature are typically lower than for many local sewer systems in the northern California coastal region.

Metcalf & Eddy (2014) estimate peaking factors for peak month, week, day, and hour flows of 1.5, 2.0, 3.0, and 4.0, respectively. Peak month, week, and day flow factors are estimated from the ratio of average sustained peak flow rates to average daily flow rates. The peak hour flow factor is estimated based on the proposed population of the PCSD service area of approximately 1,500 people. Metcalf & Eddy (2014) estimate that the peak hour flow factor is 4 for populations less than 5,000 people.

5.6 Inflow and Infiltration

Inflow and infiltration (I/I) into gravity sewer collection systems can be a major contributor to peak flows affecting collection and treatment systems sizing (especially in older systems). Much of the proposed collection system will be in low-lying areas that experience high groundwater in the wet season creating a high potential for I/I to enter the system. I/I will be minimal initially because the sewer system on the peninsula will be new, but I/I will increase over time as pipes and joints degrade, and depending on movement of the soil with seismic activity. Note that if a pressure sewer is constructed, I/I will be minimal as groundwater infiltration will not enter the pressurized pipe network. Similar to the discussion on peaking factors in the previous section, estimates of I/I from local sewer systems and reference values may over-estimate I/I flows, because these systems are constructed of older materials that have a higher likelihood of leakage.

Few data are available on the long-term effects of aging on modern plastic pipe networks given that they have not been around for more than 30 years like older pipe materials. A number of methods have been used to estimate design levels of I/I for gravity sewers including areal estimates of unit flow rates per acre of sewershed, unit flow rates per person, unit flow rates per mile of pipe, and unit flow rates per inch diameter per mile of pipe (idm). Many of these methods have been developed for estimating I/I in older sewer systems, so they might tend to over-estimate I/I for a new sewer system. The idm method is used here, because it accounts for pipe length and diameter, both of which affect I/I in a gravity sewer system. For example, larger diameter pipe has a longer circumference, and therefore more surface area exposed to groundwater, increasing the opportunity for potential infiltration into joints and cracks.



Maintenance technologies have advanced for repair of gravity sewer systems in the last few decades including trenchless pipe lining techniques, and acceptance that regular closed-circuit television (CCTV) inspections and jet cleaning are a normal part of operating a sewer system. These practices will also reduce projected I/I in newer sewer systems compared with older systems. Rates of I/I in new sewer systems may be as low as 25 gpd/idm based on a manufacturer’s specification for PVC gravity sewer pipe, including linear pipe and joints only (JM Eagle, 2017), up to 625 gpd/idm for 8-inch diameter gravity sewers (ASCD/WPCF, 1982). Other municipalities specify allowances for I/I that include the condition of the pipe near the end of its life expectancy; these estimates can be as high as 1,500 gpd/idm, with the greatest number of cities reporting allowances of 500 gpd/idm for sewer design capacity (ASCE/WPCF, 1982).

Table 5-6 includes estimates of pipe length, diameter, and idm for estimating I/I for the proposed gravity sewer systems in Fairhaven, Finntown, and the Town of Samoa. The Town of Samoa sewer system includes 6-inch and 8-inch pipe (CEC, 2017a); however, for the purposes of estimating I/I for this study, it is assumed that all gravity main is 8-inch diameter in the Town of Samoa, which will produce a more conservative estimate. Note that final pipe lengths may vary by approximately 10%.

Table 5-6: PCSD gravity sewer pipe length estimates.

| Location | Pipe Length (feet) | Inch-Diameter-Mile (idm) ¹ |
|--|--------------------|---------------------------------------|
| Fairhaven ² | 6,100 | 9.2 |
| Finntown ² | 1,400 | 2.1 |
| Town of Samoa, Phase I ^(2,3) | 9,000 | 13.6 |
| Town of Samoa, Phase II/III ^(2,3) | 8,000 | 12.1 |
| Total | 24,500 | 37.0 |

1. Assumes all gravity sewer pipe 8 inches in diameter
2. See Chapter 7 for proposed sewer layouts in Samoa, Fairhaven, and Finntown.
3. Samoa Town Master Plan phasing as defined by: California Engineering Company, 2017. *Samoa Treatment Plant Rehabilitation Project Phase I for Samoa Pacific Group*. Design Drawings. Yuba City, CA:CEC. Note: CEC designs include 6-inch and 8-inch diameter sewer pipe; all sewer pipe assumed to be 8-inch for the purposes of idm estimates included in this table.

5.6.1 Base I/I

Base I/I is added to the base sanitary flow to estimate the ADF. Base I/I when the system is new is assumed to be 50 gpd/idm, half of the maximum acceptable post-construction I/I of 100 gpd/idm as specified by the Humboldt Community Services District (HCSD, 2016). Base I/I represents dry weather I/I; this includes the assumption that groundwater will be lower during the dry season than during the wet season, less of the gravity collection system will be submerged, and there will be less hydraulic head over the gravity pipe, reducing I/I into the pipe network.

Projections for 30-year and 75-year base I/I are 500 gpd/idm and 750 gpd/idm, respectively, including the assumption that base I/I is one-half of the wet weather I/I described below. Note that a pressure sewer alternative is evaluated later in this report, which, if selected, would significantly reduce I/I estimates by eliminating groundwater infiltration.



Table 5-7: Estimated base inflow and infiltration for PCSD gravity sewer system.

| Location/Phase | New Construction Base I/I ¹ | 30-Year Base I/I | 75-Year Base I/I |
|---|--|------------------|------------------|
| I/I Allowance (gpd/idm) ² | 50 | 500 | 750 |
| Fairhaven (gpd) | 460 | 4,600 | 6,900 |
| Finntown (gpd) | 105 | 1,050 | 1,575 |
| Town of Samoa, Phase I ³ (gpd) | 680 | 6,800 | 10,200 |
| Town of Samoa, Phases II & III ³ (gpd) | 605 | 6,050 | 9,075 |
| Total (gpd) | 1,850 | 18,500 | 27,750 |

1. I/I: inflow and infiltration
2. gpd/idm: gallons per day per inch diameter mile of pipe
3. Samoa Town Master Plan phasing as defined by California Engineering Company, 2015. Application/Report of Waste Discharge - Town of Samoa - 4th Submittal. Yuba City:CEC

5.6.2 Wet Weather I/I

I/I that increases during the wet season due to rainfall and increased groundwater levels is known as rainfall derived I/I (RDII). RDII can cause excessive peak flows in older collection systems incurring significant cost to reduce flows and prevent over-loading of treatment facilities. The proposed sewer systems in the PCSD service area include new construction such that RDII will be less than expected from prior studies on older systems. Immediately following construction, RDII is estimated to be 100 gpd/idm, the maximum post-construction I/I specified by HCSD (2016).

Projections for 30-year and 75-year RDII are difficult to accurately assess, as previously mentioned, due to the fact that modern construction materials have not been around long enough to assess the aging of these systems. Based on reference values for allowable I/I in older sewer systems used for design purposes ranging from 500-1,500 gpd/idm (ASCE/WPCF, 1982), the 30-year and 75-year wet weather I/I estimates are 1,000 gpd/idm and 1,500 gpd/idm, respectively. As an example of extreme I/I, RDII as high as 67,000 gpd/idm has been estimated in another local community with a 100-year old, mostly clay pipe sewer system (SHN, 2017e).

Table 5-8 summarizes wet weather I/I estimates for the newly constructed sewer system and projected 30-year and 75-year timeframes. Note that a pressure sewer alternative is evaluated later in this report, which, if selected, would significantly reduce I/I estimates by eliminating groundwater infiltration.



Table 5-8: Estimated wet weather inflow and infiltration for PCSD gravity sewer system.

| Location/Phase | New Construction Base I/I ¹ | 30-Year Base I/I | 75-Year Base I/I |
|---|--|------------------|------------------|
| I/I Allowance (gpd/idm) ² | 100 | 1,000 | 1,500 |
| Fairhaven (gpd) | 920 | 9,200 | 13,800 |
| Finntown (gpd) | 210 | 2,100 | 3,150 |
| Town of Samoa, Phase I ³ (gpd) | 1,360 | 13,600 | 20,400 |
| Town of Samoa, Phases II & III ³ (gpd) | 1,210 | 12,100 | 18,150 |
| Total (gpd) | 3,700 | 37,000 | 55,500 |

1. I/I: inflow and infiltration
2. gpd/idm: gallons per day per inch diameter mile of pipe
3. Samoa Town Master Plan phasing as defined by California Engineering Company, 2015. Application/Report of Waste Discharge - Town of Samoa - 4th Submittal. Yuba City:CEC

5.7 Design Flows

Table 5-9 includes estimated design flow rates for the proposed Samoa Peninsula wastewater system, assuming a gravity sewer system is constructed in the communities of Fairhaven, Finntown, and the Town of Samoa. Note that a pressure sewer alternative is evaluated later in this report, which, if selected, would significantly reduce I/I estimates by eliminating groundwater infiltration. For the estimates of current design flows listed in Table 5.8, I/I accounts for only 3% and 6% of ADWF and AWWF, respectively. For the estimates of 30-year projected design flows listed in Table 5.8, I/I accounts for 10% and 19% of ADWF and AWWF, respectively. And for the 75-year projected design flows listed in Table 5.8, I/I accounts for 15% and 26% of ADWF and AWWF, respectively. Implementation of a pressure sewer will eliminate groundwater infiltration into pipelines, but will only reduce inflow by reducing the number of manholes in the system where surface water can enter the collection system.



Table 5-9: Estimated design sanitary wastewater flow rate summary for the Peninsula Community Services District service area for a gravity sewer system.

| Flow Rate | Current Flow Estimate (gpd ¹) | 30-Year Flow Projection (gpd) | 75-Year Flow Projection (gpd) |
|---|---|-------------------------------|-------------------------------|
| Minimum Day Flow ² | 16,997 | 47,215 | 47,215 |
| Base Sanitary Flow ³ | 56,658 | 157,384 | 157,384 |
| Base I/I ⁴ Flow ⁵ | 1,850 | 18,500 | 27,750 |
| Wet Weather I/I Flow ⁶ | 3,700 | 37,000 | 55,500 |
| Average Dry Weather Flow ⁷ | 58,508 | 175,884 | 185,134 |
| Average Daily Flow ⁸ | 59,433 | 185,134 | 199,009 |
| Average Wet Weather Flow ⁹ | 60,358 | 194,384 | 212,884 |
| Peak Month Flow ¹⁰ | 89,149 | 277,701 | 298,513 |
| Peak Week Flow ¹¹ | 118,865 | 370,268 | 398,018 |
| Peak Day Flow ¹² | 178,298 | 555,402 | 597,027 |
| Peak Hour Flow ¹³ | 237,730 | 740,535 | 796,035 |

1. gpd: gallons per day
2. Minimum flow rate estimated as 30% of BSF
3. BSF: Base sanitary flows assume 244 gpd per equivalent dwelling unit.
4. I/I: inflow and infiltration. Note that a pressure sewer alternative is evaluated later in this report, which, if selected, would significantly reduce I/I estimates by eliminating groundwater infiltration.
5. Base I/I flow: 50 gpd per inch diameter mile (idm) of pipe for new construction, 500 gpd/idm for 30-year projection, and 750 gpd/idm for 75-year projection.
6. Wet weather I/I flow: 100 gpd/idm for new construction, 1,000 gpd/idm for 30-year projection, and 1,500 gpd/idm for 75-year projection.
7. Average dry weather flow estimated as the sum of the base sanitary flow and base I/I flow.
8. Average daily flow estimated as the average of the average dry and wet weather flows.
9. Average wet weather flow estimated as the sum of the base sanitary flow and wet weather I/I flow.
10. Peak month flow estimated as 1.5 times the average daily flow.
11. Peak week flow estimated as 2.0 times the average daily flow.
12. Peak day flow estimated as 3.0 times the average daily flow.
13. Peak hour flow estimated as 4.0 times the average daily flow.



5.8 Pollutant Loads

No raw wastewater quality data are available for the peninsula, so typical (medium-strength) reference values for pollutant concentrations are used (Table 5.9). Based on the WWTP design horizon of 30 years, the 30-year projected average wet weather flow is used to estimate design pollutant loads.

Table 5-10: Typical untreated domestic wastewater pollutant concentrations and loads.

| Pollutant | Typical Concentration ¹ (mg/L ² unless otherwise noted) | Typical Individual Load ³ (ppd ⁴) | Typical Load ⁵ , Current Population ⁶ (ppd) ⁷ | Typical Load, Full Buildout Population ⁸ (ppd) |
|--------------------------------------|---|--|--|---|
| Total Dissolved Solids (TDS) | 560 | -- ⁹ | 416 | 1,297 |
| Total Suspended Solids (TSS) | 195 | 0.15 | 72 | 224 |
| Settleable Solids (SS) ¹⁰ | 12 | -- | 9 | 28 |
| Biochemical Oxygen Demand (BOD) | 200 | 0.15 | 72 | 224 |
| Total Organic Carbon (TOC) | 164 | -- | 122 | 380 |
| Chemical Oxygen Demand (COD) | 508 | 0.40 | 192 | 596 |
| Total Nitrogen (as N) | 35 | -- | 26 | 81 |
| Total Organic Nitrogen (as N) | 14 | 0.012 | 5.8 | 18 |
| Total Ammonia Nitrogen (as N) | 20 | 0.017 | 8.2 | 25 |
| Total Phosphorus (as P) | 5.6 | 0.0046 | 2.2 | 6.9 |
| Total Organic Phosphorus (as P) | 3.2 | 0.0026 | 1.2 | 3.9 |
| Total Inorganic Phosphorus (as P) | 2.4 | 0.0020 | 1.0 | 3.0 |
| Total Coliform ¹¹ | 10 ⁷ - 10 ⁹ | NA ¹² | NA | NA |
| Fecal Coliform ¹¹ | 10 ⁴ - 10 ⁶ | NA | NA | NA |

1. Medium strength wastewater pollutant concentrations from: Metcalf & Eddy, 2014. *Wastewater Engineering Treatment and Resource Recovery*. 5th Ed. New York, NY:McGraw-Hill.
2. mg/L: milligrams per liter
3. Metcalf & Eddy, 2014.
4. ppd: pounds per day
5. Pollutant mass loads calculated using the 30-year projected peak month flow rate.
6. Current estimated 2017 PCSD population is 480 people.
7. Loads calculated using typical individual loads and PCSD population where available; otherwise typical concentration and peak monthly flow rate used to calculate loads.
8. Projected full buildout PCSD population is 1,541 people.
9. --: individual load not given
10. Measured as milliliters per liter
11. Measured as number of colonies per 100 milliliters
12. NA: not applicable



6. Alternatives Analysis

Section 6 of this PER has been divided into four sub-sections based on the overall wastewater treatment process: the collection area and collection system, wastewater treatment, wastewater disposal, and solids treatment. Table 6-1 lists the alternatives considered by project process. The no action alternative would be to leave the Samoa Peninsula with old, failing, unconsolidated septic systems, which will eventually lead to groundwater contamination while limiting residential and commercial growth. Each design assumes one PCSD consolidated treatment plant in order to share capital costs and labor needs across a larger customer base.

Table 6-1: List of alternatives considered for each project component.

| Proposed Project Component | Alternatives |
|----------------------------|---|
| Collection System | <ol style="list-style-type: none"> Gravity Sewer System Pressure Sewer System |
| Treatment | <ol style="list-style-type: none"> Sequencing Batch Reactor (SBR) Process Advantex Process Recirculating Gravel Filter (RGF) Reverse Osmosis (RO) Chlorine Disinfection Ultraviolet (UV) Disinfection |
| Effluent Disposal | <ol style="list-style-type: none"> Land Disposal Ocean Disposal |
| Solids Handling | <ol style="list-style-type: none"> Independent Contractor On-site Dewatering |

Each project component section will contain a system and alternatives description, including design criteria, potential environmental impacts, land and permit requirements, construction issues, and cost estimates; concluding with a comparison of alternatives. Section 7 describes the recommended project alternative.

6.1 Collection System

6.1.1 Collection System Description

The objective of this project is to collect, convey, and treat domestic wastewater from each user in the PCSD service area. To this end, a single pressure main is proposed to run from the boat ramp

Data Disclaimer:
 Town of Samoa wastewater collection system layout from California Engineering Company, 2017. Samoa Treatment Plant Rehabilitation Project. Design Plans.

Legend

- (P) Pump Stations**
- PCSD
- STMP
- Other
- (P) Pressure Main
- (P) Gravity Main (STMP)
- - - (P) Collection System (type to be determined)
- · - · (E) Ocean Outfall
- Samoa Town Master Plan Area
- ▭ (P) Peninsula CSD Boundary

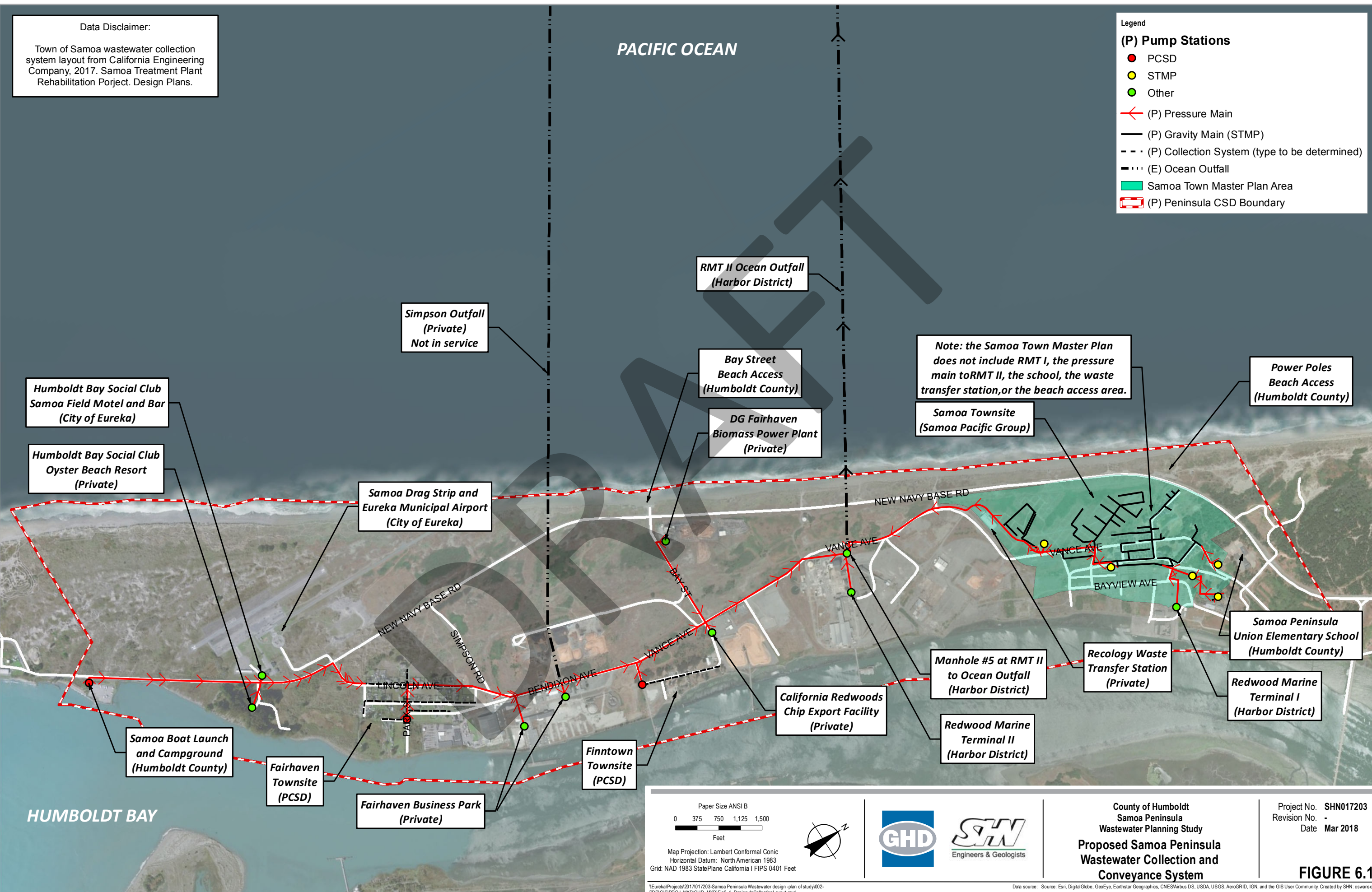

Note: the Samoa Town Master Plan does not include RMT I, the pressure main to RMT II, the school, the waste transfer station, or the beach access area.

Paper Size ANSI B
 0 375 750 1,125 1,500
 Feet

Map Projection: Lambert Conformal Conic
 Horizontal Datum: North American 1983
 Grid: NAD 1983 StatePlane California I FIPS 0401 Feet



County of Humboldt
 Samoa Peninsula
 Wastewater Planning Study
**Proposed Samoa Peninsula
 Wastewater Collection and
 Conveyance System**

Project No. SHN017203
 Revision No. -
 Date Mar 2018

FIGURE 6.1

\\Eureka\Projects\20170117203-Samoa Peninsula Wastewater design - plan of study\002-PDR\GIS\PROJ_MXD\GHD_MXD\Fig6_1_PeninsulaCollectionLayout.mxd
 Print date: 08 Mar 2018 - 14:24

DRAFT



and campground on the southern end of the PCSD service area to Manhole 5 at RMT-II (Town of Samoa)

The Town of Samoa has plans for a gravity collection and conveyance system as a part of the STMP (Figure 6-2). Control and ownership of the Town of Samoa systems will be transferred to PCSD once LAFCo approval is gained and a plan is agreed upon for transfer of ownership. A dedicated pressure main is proposed to convey treated effluent from the proposed Town of Samoa WWTP to Manhole 5 at RMT-II for discharge to the ocean outfall; although SPG is pursuing this option in addition to an alternate disposal option using a disposal field.

In addition to sewer connections in the Town of Samoa proposed by the STMP, it is assumed that the Peninsula Union Elementary School will also eventually connect to the Town of Samoa collection system (Table 6-3). It is uncertain during which development phase this would occur, because the school cannot connect to the new system until control and ownership of the wastewater infrastructure is transferred to the PCSD. It is also assumed that the Recology waste transfer station will eventually connect to the Town of Samoa wastewater system; however, the transfer station currently has a non-standard aerated treatment system and leachfield that they may elect to continue using.

Table 6-3: Town of Samoa existing and proposed sewer connections by development phase¹.

| User Class | Existing | Phase I | Phase II | Phase III | Total |
|---------------|-----------|------------|------------|-----------|------------|
| Residential | 93 | 93 | 167 | 0 | 353 |
| Commercial | 3 | 10 | 0 | 24 | 37 |
| Industrial | 0 | 2 | 0 | 0 | 2 |
| Recreational | 0 | 0 | 0 | 0 | 0 |
| Institutional | 3 | 0 | 0 | 0 | 3 |
| Total | 99 | 105 | 167 | 24 | 396 |

1. CEC, 2015. *Application/Report of Waste Discharge - Town of Samoa - 4th Submittal*. Yuba City, CA:CEC.

Town of Fairhaven

The Town of Fairhaven does not have a centralized sanitary sewer collection system. The proposed sewer layout for the town of Fairhaven will serve existing homes with capacity for infill development of parcels within the existing developed area. Legal parcels outside the existing developed areas may become sewerred in the future; however, permitting challenges associated with placing new sewer lines in undeveloped areas, and similar challenges associated with new home construction in these areas have excluded them from the initial phase of development considered in this study. Many areas on the Samoa peninsula include ESHA that have historically been protected by the California Coastal Commission, restricting construction activities due to potential environmental impacts.

The Town of Fairhaven sewer system will need to serve the Samoa Peninsula Fire Protection District headquarters building (the Fire Hall) that will serve as the PCSD headquarters in the future, in addition to existing and new residences constructed on existing infill lots.



Each user along the alignment would connect to the primary pressure main. The PCSD service area varies in elevation from sea level to a maximum of approximately 40 feet (North American Vertical Datum of 1988 [NAVD88]), and is approximately 4 miles long, creating long distances with little elevation to assist a gravity sewer system.

Conveyance of domestic wastewater from each user in the PCSD service area to a centralized treatment facility will require pumping and pressure mains due to the long distances and shallow groundwater on the peninsula. Large industrial process flows are assumed to be the responsibility of the individual private entity and it is assumed they will not be conveyed in the PCSD collection and conveyance system. Domestic wastewater from industrial facilities is assumed to be included in the design of the PCSD.

A long pressure main sewer pipe along the peninsula will create septic wastewater, which when discharged at the new WWTP may be corrosive, odorous, and produce noxious gasses (hydrogen sulfide). Additional considerations for scrubbing air vents along the pressure main may be required to prevent discharge of noxious gasses to the atmosphere, and foul odors in public areas. Wastewater discharged from the pressure main at the treatment facility may off-gas toxic hydrogen sulfide gas. Hydrogen sulfide is not only toxic to inhale, it can create corrosive sulfuric acid as it condenses on equipment, reducing the life-expectancy of equipment near the discharge point into the treatment facility. Chemicals and scrubbers can be added to the wastewater system to reduce odors and treat the hydrogen sulfide.

Potential connections to the PCSD collection and conveyance system may include residential areas managed by the PCSD, commercial and industrial facilities, public recreation areas, and publicly owned commercial and industrial facilities as detailed in Table 6-2.

Table 6-2: Potential sewer connections in the PCSD¹ service area.

| User Class | Existing Connections ² | Proposed Connections (Total) ³ |
|-------------------------|-----------------------------------|---|
| Residential | 169 | 491 |
| Commercial ⁴ | 13 | 21 |
| Recreational | 1 ⁵ | 1 ⁵ |
| Institutional | 4 | 4 |
| Total | 187 | 543 |

1. PCSD: Peninsula Community Services District
2. Potential existing connections include existing residential, commercial and institutional users in the Towns of Samoa, Fairhaven, and Finntown, and commercial users along the pressure main between the communities.
3. Proposed connections include all existing connections described above and all proposed full build-out connections in the Towns of Fairhaven, Finntown, and Samoa.
4. Industrial properties that connect to the PCSD municipal sewer system for disposal of sanitary waste are categorized as commercial users.
5. Existing recreational connections may include the boat ramp and campground; it is assumed the drag strip will connect at the same location as the Humboldt Bay Social Club.

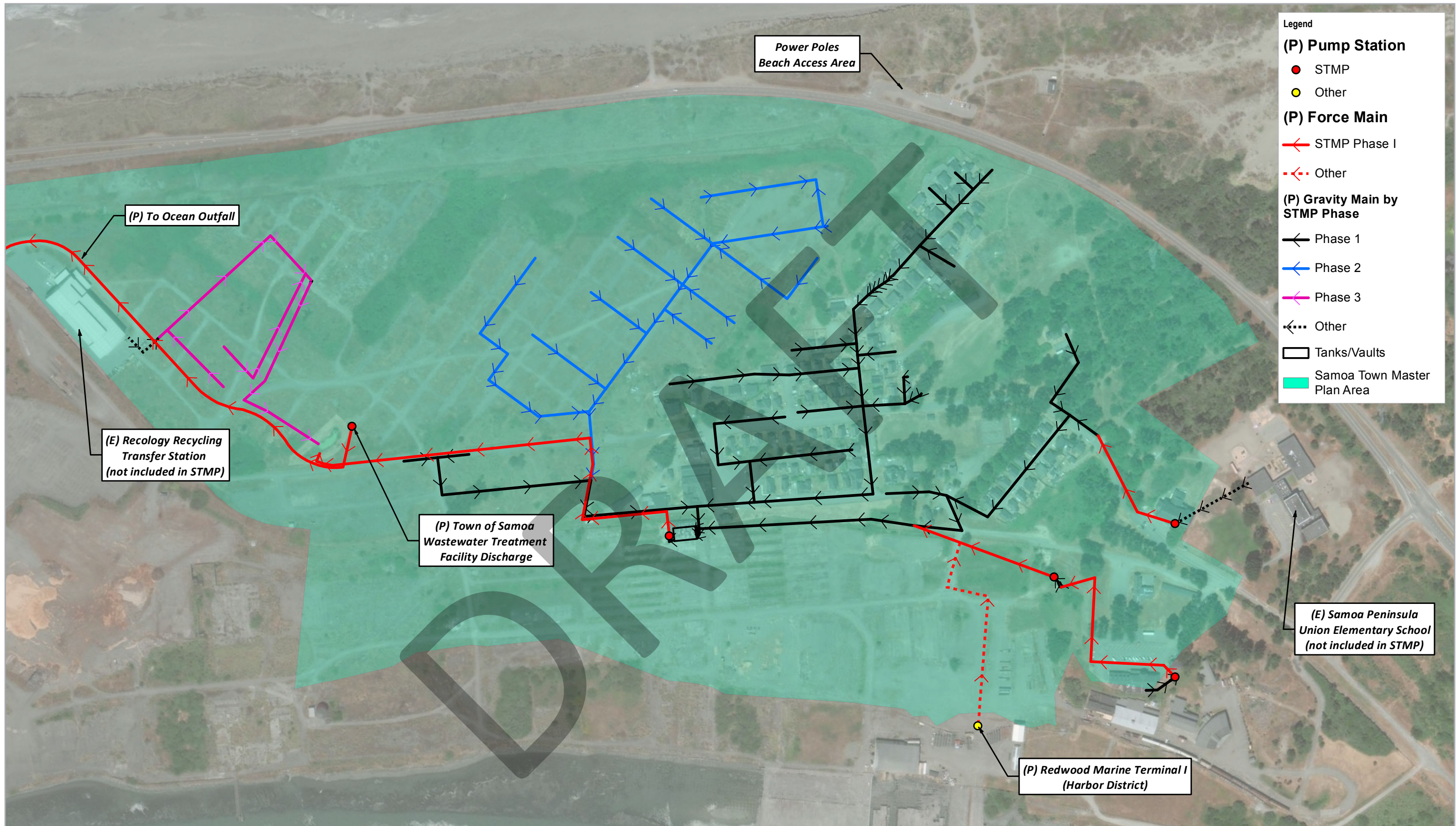

Legend

(P) Pump Station

- STMP
- Other

(P) Force Main

- STMP Phase I
- - - Other

(P) Gravity Main by STMP Phase

- ← Phase 1
- ← Phase 2
- ← Phase 3
- ←... Other

□ Tanks/Vaults

■ Samoa Town Master Plan Area

Data Disclaimer

Collection system location is approximate and for planning purposes only.

Proposed gravity collection pipe locations from California Engineering Company, 2017.

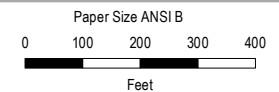

Map Projection: Lambert Conformal Conic
Horizontal Datum: North American 1983
Grid: NAD 1983 StatePlane California I FIPS 0401 Feet



County of Humboldt
Samoa Peninsula
Wastewater Planning Study

**Proposed Town of Samoa
Wastewater Collection and
Conveyance System**

Project No. SHN017203
Revision No. -
Date Mar 2018

FIGURE 6.2

DRAFT



Town of Samoa

The Town of Samoa has plans for a gravity collection and conveyance system as a part of the STMP (Figure 6-2). Control and ownership of the Town of Samoa systems will be transferred to PCSD once LAFCo approval is gained and a plan is agreed upon for transfer of ownership. A dedicated pressure main is proposed to convey treated effluent from the proposed Town of Samoa WWTP to Manhole 5 at RMT-II for discharge to the ocean outfall; although SPG is pursuing this option in addition to an alternate disposal option using a disposal field.

In addition to sewer connections in the Town of Samoa proposed by the STMP, it is assumed that the Peninsula Union Elementary School will also eventually connect to the Town of Samoa collection system (Table 6-3). It is uncertain during which development phase this would occur, because the school cannot connect to the new system until control and ownership of the wastewater infrastructure is transferred to the PCSD. It is also assumed that the Recology waste transfer station will eventually connect to the Town of Samoa wastewater system; however, the transfer station currently has a non-standard aerated treatment system and leachfield that they may elect to continue using.

Table 6-3: Town of Samoa existing and proposed sewer connections by development phase¹.

| User Class | Existing | Phase I | Phase II | Phase III | Total |
|---------------|-----------|------------|------------|-----------|------------|
| Residential | 93 | 93 | 167 | 0 | 353 |
| Commercial | 3 | 10 | 0 | 24 | 37 |
| Industrial | 0 | 2 | 0 | 0 | 2 |
| Recreational | 0 | 0 | 0 | 0 | 0 |
| Institutional | 3 | 0 | 0 | 0 | 3 |
| Total | 99 | 105 | 167 | 24 | 396 |

1. CEC, 2015. *Application/Report of Waste Discharge - Town of Samoa - 4th Submittal*. Yuba City, CA:CEC.

Town of Fairhaven

The Town of Fairhaven does not have a centralized sanitary sewer collection system. The proposed sewer layout for the town of Fairhaven will serve existing homes with capacity for infill development of parcels within the existing developed area. Legal parcels outside the existing developed areas may become sewered in the future; however, permitting challenges associated with placing new sewer lines in undeveloped areas, and similar challenges associated with new home construction in these areas have excluded them from the initial phase of development considered in this study. Many areas on the Samoa peninsula include ESHA that have historically been protected by the California Coastal Commission, restricting construction activities due to potential environmental impacts.

The Town of Fairhaven sewer system will need to serve the Samoa Peninsula Fire Protection District headquarters building (the Fire Hall) that will serve as the PCSD headquarters in the future, in addition to existing and new residences constructed on existing infill lots.



Finntown

Finntown does not have a centralized sanitary sewer collection system. Finntown consists of approximately 10 homes on individual septic systems along Fay Street. No development is expected in Finntown due to the coastal dependent industrial zoning. Existing homes may be serviced by a single line running north to south along Fay Street, turning west on Comet Street to connect with the primary peninsula force main running along Bendixon Street and Vance Avenue.

A new sewer system in Finntown will need to provide sanitary sewer service to the boat yard and the dive shop in addition to existing residences.

6.1.2 Collection System Alternatives

Collection system alternatives include gravity and pressure networks. Due to the difficulty of deep trenching in saturated loose sandy soils and the potential for shallow groundwater infiltration into gravity collection pipes, shallower and water-tight pressure networks are considered as an alternative to a gravity system. A portion of the primary conveyance system must be pressurized between service areas due to the long distances and flat topography of the peninsula. Alternatives have been considered for pressurizing the collection and conveyance systems in the residential areas of Fairhaven and Finntown. No alternative has been considered for the Town of Samoa, because the STMP already includes a design for the collection system to be funded and constructed separately from this project.

Gravity collection systems are typically less expensive and simpler to maintain, because there are fewer moving parts, such as pumps and valves, compared with a pressurized system. However, pressure systems may be less expensive to install in areas like the peninsula where there is shallow groundwater and loose sandy soils. Saturated sandy soils will significantly increase the cost, difficulty, and danger associated with deeper trenching during construction of a gravity system.

6.1.2.1 No Action Alternative

The no action alternative would entail keeping the existing individual septic and mound treatment systems with individual leachfields everywhere except in the Town of Samoa. As stated elsewhere in this report, the Town of Samoa has plans to construct a new WWTP and obtain an NCRWQCB permitted discharge either to a land-based disposal field in the Town of Samoa or to the ocean outfall at RMT-II.

6.1.2.2 Gravity Sewer

Gravity sewers are traditionally used to convey wastewater where shallow groundwater and pipe slope are not a problem. Gravity sewers typically include minimum pipe slopes of approximately 0.5% (0.005 ft/ft) to maintain minimum water velocity that prevents solids accumulation in the sewer pipes. This results in deeper pipe networks, because pipes must continually slope downward. One of the main advantages of a gravity sewer is that little or no power is required for pumping. However, many systems include lift stations when sufficient ground slope is not available to prevent the system from becoming too deep. Pipes will slope to a lift station where wastewater is pumped to a higher elevation and gravity flows to the next lift station. Another drawback of gravity sewers is infiltration of groundwater, given that the pipes are not designed to flow full. An empty pipe below

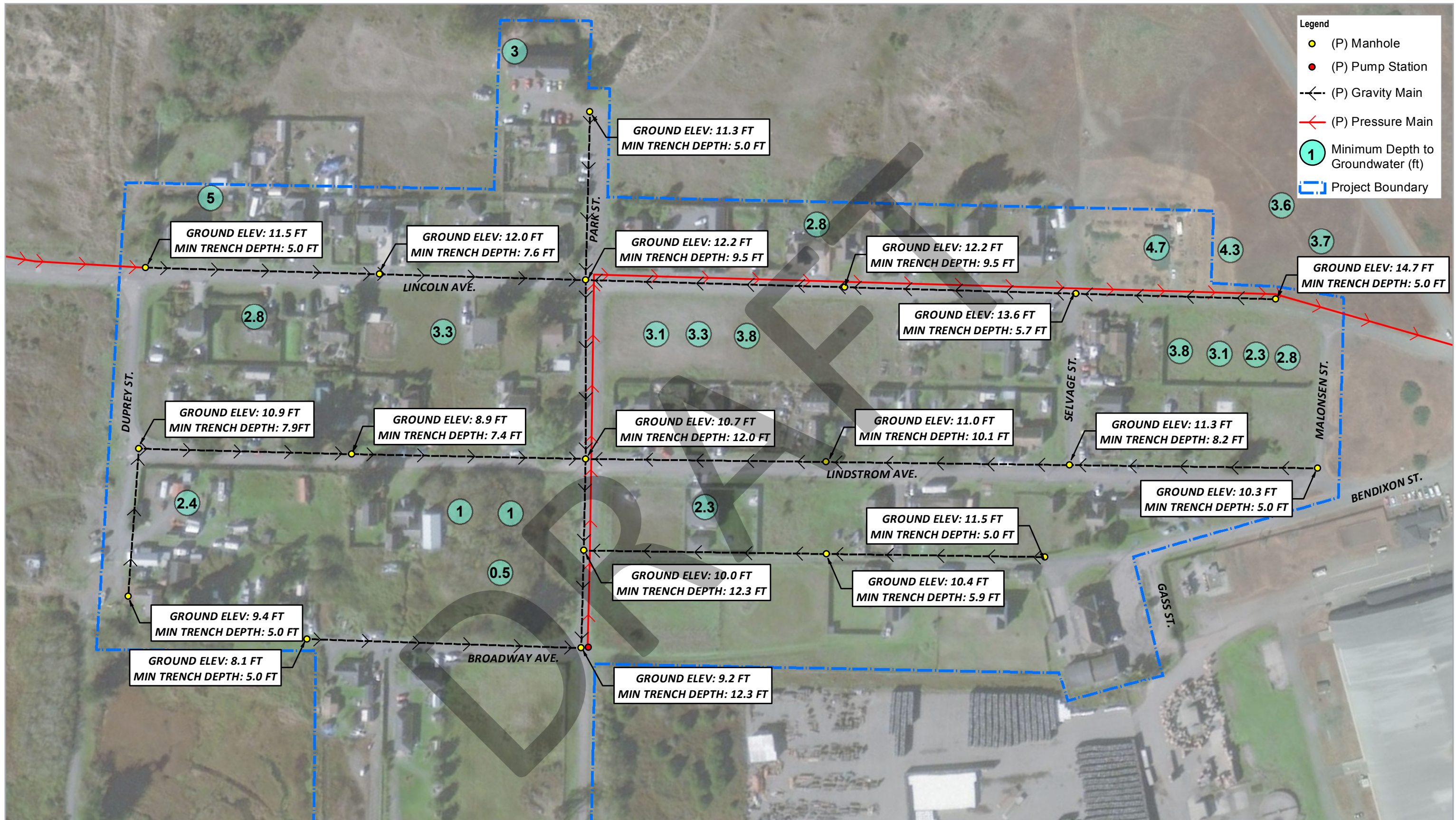

Data Disclaimer
 Sewer system feature locations are approximate and for planning purposes only.
 Depth to water data from septic system studies taken during the wet season.
 Ground elevation data from Lidar (NAVD 88)

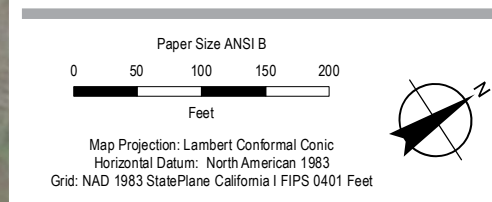

County of Humboldt
 Samoa Peninsula
 Wastewater Planning Study

Project No. SHN-017203
 Revision No. -
 Date Feb 2018

**Proposed Fairhaven
 Gravity Sewer Layout**

FIGURE 6.3

\\Eureka\Projects\2017\017203-Samoa Peninsula Wastewater design - plan of study\002-PDR\GISPROJ_MXD\GHD_MXD\Fig6_3_FairhavenCollection_Gravity.mxd
 Print date: 16 Feb 2018 - 12:25
 Data source: Source: Esri, DigitalGlobe, GeoEye, Earthstar Geographics, CNES/Airbus DS, USDA, USGS, AeroGRID, IGN, and the GIS User Community. Created by: cswanson

DRAFT

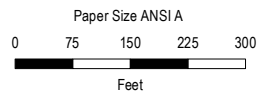

Map Projection: Lambert Conformal Conic
Horizontal Datum: North American 1983
Grid: NAD 1983 StatePlane California I FIPS 0401 Feet



County of Humboldt
Samoa Peninsula
Wastewater Planning Study
**Proposed Finntown Gravity
Wastewater Collection and
Conveyance System**

Project No. SHN017203
Revision No. -
Date Mar 2018

FIGURE 6.4

DRAFT



groundwater level acts as a drain, with groundwater pressure forcing freshwater into the sewer system, significantly increasing flows into a WWTP (a detailed discussion of this is included previously in Chapter 5).

Gravity sewer systems require periodic closed circuit television (CCTV) inspection and high pressure water jetting for cleaning. Gravity sewers are also more likely to become plugged by grease accumulation, resulting in sanitary sewer overflows (SSOs). To maintain access for cleaning and inspection, gravity sewers typically include manholes every 500 feet or less.

Perhaps the most significant drawback of a gravity sewer system in the PCSD service area is the risk of damage during an earthquake. The PCSD service area is in an area with a very high risk of significant earthquake events, which, coupled with the loose sandy soils and shallow groundwater on the peninsula, creates a high potential for soil liquefaction. Gravity sewer pipes are designed for less than full-pipe flow, meaning the pipes will contain air which increases the buoyancy of the pipe network. If the soils holding the pipes in place were to liquefy during an earthquake, the pipes could float, decreasing or reversing the pipe slopes required to maintain flow. This could result in system failure, and require costly repair.

Advantages:

- Low power requirements.
- Low maintenance required.
- Low O&M costs.
- Minimal number of pump stations decreases O&M.

Disadvantages:

- Risk of significant damage during earthquake events.
- High potential for groundwater infiltration.
- Increased potential for groundwater contamination.
- Deeper pipes required to maintain minimum slopes; results in more costly construction (shoring and dewatering).
- Maintenance includes regular camera inspection and jet cleaning.

Town of Fairhaven

Evaluation of a gravity collection system for the Town of Fairhaven indicates that minimum trench depths of up to 12.3 feet can be expected (Figure 6-3). Groundwater depth data from leachfield infiltration studies indicate that minimum groundwater depths of less than 1.0 foot can occur near the deepest parts of the collection system. These data were likely collected during the wet season, which is typical for septic system studies, and the proposed new collection will likely be constructed during the dry season. Depth to groundwater during the dry season is uncertain at this time; however, given that the deepest part of the system (12.3 feet deep) is nearest the bay, the ground surface elevation near that part of the system is approximately 9 feet above sea level, and the fact that freshwater is mounded above sea level, groundwater is expected to be higher than the proposed pipe depth in parts of the system during any time of the year. The gravity system would require a single large pump station at the east end of Park Street.



Finntown

Finntown is small enough to be served by a single sewer main running along Fay Street. Finntown's single sewer main alignment is closer to the bay than Fairhaven such that elevations along the pipe alignment range from approximately 12 to 14 feet above sea level (North American Vertical Datum 1988; Figure 6-4). Given the minimum gravity pipe slope of 0.5% and manhole placement every 300 feet, a minimum gravity sewer main depth of 12.6 feet can be expected (nearly 1 foot below sea level). Because the lowest portion of the collection system would fall below sea level, so too would the pump station. The pump station is also expected to be up to 5 feet deeper than the minimum trenching depth for the gravity pipe due to the need for storage volume.

6.1.2.3 Pressure Sewer

A pressure system would eliminate the need for deeper trenching to accommodate sloped gravity pipes, reducing the overall depth of the pipe network to approximately 5 feet. Because a pressure sewer is not dependent on pipe slope to maintain proper flows, the risk of system upset or failure during an earthquake is less than for a traditional gravity system. Pressure sewers also consist of water-tight pipe connections, reducing the potential for exfiltration and groundwater pollution, while virtually eliminating groundwater infiltration. There are two options for a pressurized sewer system: septic tank effluent pump (STEP) and grinder pump (GP).

STEP systems include septic tanks that receive residential wastewater, settle out solids, and then pump the liquid into a pressurized sewer pipe. STEP systems significantly reduce solids and BOD loading to a WWTP by removing primary solids prior to pumping supernatant to the WWTP. Sludge accumulated in each septic tank needs to be removed periodically and disposed of. The cost of pumping septic tanks may be offset by reducing the costs of treatment at the centralized WWTP. The condition of the septic tanks on the peninsula is unclear, however, it is assumed that the majority of the existing tanks would need to be replaced to eliminate potential contamination of groundwater from failing systems. A STEP system could consist of individual septic tanks at each residence, or larger septic tanks that serve multiple homes. The second option would include gravity flow laterals from each residence to the septic tank, which would then pump into a pressure main. This option would reduce the number of pumps and septic tanks requiring maintenance by PCSD personnel. Pump stations can be owned and maintained by PCSD or a third party service.

GP systems include a small pump station located at each residence consisting of a small tank (approximately 100-300 gallons), and a small grinder pump (approximately 1.5 horsepower [hp]). The grinder pumps macerate solids in wastewater creating a slurry that reduces the potential for plugging pipes. The slurry typically has higher BOD and TSS concentrations than the raw, un-macerated, wastewater. Pump stations can be owned and maintained by PCSD, individual property owners, or a third party service.

The nearby community of Manila on the Samoa Peninsula has a STEP pressurized sewer system owned and operated by the CSD (Drop, 2018). Manila's system reportedly requires a significant amount of maintenance, primarily with respect to the pumps located at each septic tank. The system in Manila was installed in the 1970s when these types of systems were relatively new. Newer pressure sewer systems reportedly require very little maintenance with a mean time between



Paper Size ANSI A
 0 75 150 225 300
 Feet

Map Projection: Lambert Conformal Conic
 Horizontal Datum: North American 1983
 Grid: NAD 1983 StatePlane California I FIPS 0401 Feet



County of Humboldt
 Samoa Peninsula
 Wastewater Planning Study

Proposed Fairhaven
 Pressure Sewer Layout

Project No. SHN017203
 Revision No. -
 Date Feb 2018

FIGURE 6.5

DRAFT



Data Disclaimer
Sewer system locations are approximate and for planning purposes only.

Private laterals may be funded and constructed separately, and are shown for reference only.

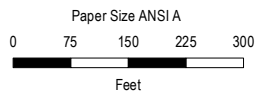

Map Projection: Lambert Conformal Conic
Horizontal Datum: North American 1983
Grid: NAD 1983 StatePlane California I FIPS 0401 Feet



County of Humboldt
Samoa Peninsula
Wastewater Planning Study
**Proposed Finntown Pressure
Wastewater Collection and
Conveyance System**

Project No. SHN017203
Revision No. -
Date Mar 2018

FIGURE 6.6

DRAFT



service calls (MTBSC) of approximately 4 years (i.e., 25% of pumping units will require service each year; EPA, 1991).

Advantages

- Reduced risk of significant damage during earthquakes.
- Shallow pipe network reduces cost/complexity of trenching during construction.
- Shallow pressurized pipes prevent infiltration of groundwater from entering system, which can reduce the cost of pumping and treatment.
- GP: reduces particle size of solids and debris, reducing need for screening at WWTP.
- STEP: reduces solids and BOD, reducing loading to WWTP, which can result in a decrease in treatment costs.

Disadvantages

- Valve or pipe failure can result in large sanitary sewer overflow events.
- High capital cost of construction for purchase and installation of many individual pump stations and/or septic tanks.
- GP systems: individual small grinder pump systems at each home can result in more frequent system maintenance, increasing the overall O&M cost for the system.
- GP systems: increases BOD and TSS loading to WWTP, which may increase the cost of treatment.
- STEP systems: requires periodic sludge pumping from septic tanks.
- STEP systems: septic tanks increase capital cost and encumber more land than GP systems.
- During extended power outages, operators may have to use a portable generator to pump each individual residential pump station.

Town of Fairhaven

A pressurized conveyance system would follow the same alignment as the gravity system, but would eliminate one length of pipe running down Park Street compared with the gravity system (Figure 6-5).

Finntown

A pressure collection system in Finntown has the same advantages and disadvantages as those stated previously for the Town of Fairhaven, and the same basic layout as for the Finntown gravity sewer system described previously (Figure 6-6).

6.1.3 Collection System Design Criteria

Humboldt Community Services District (HCSD) has published sewer design and construction standards specifying materials, installation, and design criteria for gravity and pressure sewer systems. The HCSD standards have been used to establish criteria for the potential PCSD sewer collection system where applicable. The following is a summary of design criteria related to the PCSD sewer project, for more detail see the HCSD standards document (HCSD, 2016).



6.1.3.1 General Sewer System Design Criteria

Alignment

All sewer pipe and pumping infrastructure should be located within public rights-of-way, following existing streets wherever possible to minimize environmental impacts and permitting requirements for ESHAs. Minimum separation from potable water pipes should be maintained according to the State of California Department of Health Services "Criteria for the Separation of Water and Sanitary Sewer Main." Typical separation is 1 foot vertically with the sewer line located below the water line, and 10 feet horizontally (CCR 22§64630).

PCSD Accessibility

Sewer mains and manholes should be within existing paved roads wherever possible and all sewer easements should be a minimum of 20 feet in width.

6.1.3.2 Gravity Sewer Design Criteria

Pipe Material

All gravity sewer pipe should be polyvinyl chloride (PVC).

Pipe Diameter

Gravity mains should maintain a minimum diameter of 8 inches to allow for television inspection and jet cleaning access.

Slope and Velocity

Gravity sewers should maintain a minimum water velocity of 2 feet per second (fps) when flowing full using Manning's roughness factor of $n=0.011$ for new pipe.

Manholes and Cleanouts

Manholes should be placed at every horizontal or vertical change in alignment with a maximum distance of 500 feet between manholes. Manholes or cleanouts should be placed at the end of every main for proper operation and maintenance access. Private mains should connect to the PCSD mains at a manhole. Laterals

Gravity sewer laterals serving individual residences connecting to the sewer mains should maintain a minimum slope of 2% or 0.25 inch/foot.

6.1.3.3 Pressure Sewer Design Criteria

Operating Conditions

Pressure mains should be sized to maintain pressure standards under the worst case scenario of total dynamic head (TDH) and assuming 25% of individual pump stations discharge at the same time.

Pipe Material



Pressure sewer pipe materials should meet the design operating pressure conditions specified by the design engineer and may include PVC, C900, or high density polyethylene (HDPE). Iron or metal pipe should not be used in a pressure sewer system due to the corrosivity of the septic waste in the pipes, which can cause corrosion of metal pipes and premature failure.

Pipe Diameter

Pressure mains should maintain a minimum diameter of 3 inches, and pressure laterals should maintain a minimum diameter of 2 inches.

Private Pump Stations

Individual pump stations should be designed to operate between 5-20 gallons per minute (gpm) at pressures below 100 pounds per square inch (psi).

Pipeline Inspection Gauge (PIG) Launching and Receiving Stations

PIGs are devices inserted into a pressure pipe that are pushed through the pipe by fluid pressure. PIGs scour accumulated debris on the interior pipe walls and clear blockages. PIG launching and receiving stations should be installed in pressure main pipes at each change in horizontal alignment, vertical alignment, or change in diameter, to allow access for the insertion of the PIG.

Air Relief Valves

Air relief valves should be installed at any rise in the pipe alignment to allow venting of trapped air that could disrupt normal flow of wastewater in the pressure pipe. Due to the septic nature of wastewater in full-pipe flow conditions, air vented from a pressure pipe should be scrubbed before discharge to the atmosphere to remove hazardous gasses and offensive odors.

6.1.4 Collection System Potential Environmental Impacts

Collection system piping is proposed to be installed within existing roadways to minimize impacts to environmentally sensitive areas. An Environmental Impact Report (EIR) is being prepared to comply with the California Environmental Quality Act (CEQA). Impact categories requiring mitigation are anticipated to potentially include, but may not be limited to, air quality, biological resources, and cultural resources. Air vented from a pressure sewer can be odorous and potentially hazardous, requiring filtration prior to atmospheric release. All air vents on pressure mains should include air scrubbers to prevent hazardous and offensive conditions.

6.1.5 Collection System Land and Permitting Requirements

Because all collection system piping is proposed to be installed within existing roadways, it is assumed that no easements or right-of-way will need to be obtained from landowners. Encroachment permit(s) will be required from Humboldt County Department of Public Works, Land Use Division for work within County rights-of-way. The project may also require a conditional use permit from the County. However, if the project is seen as exclusively a municipal/public project, this permit may not be required. An ACOE Clean Water Act Section 404/Section 10 permit would be required if the project were to involve filling of or work in Waters of the U.S. A RWQCB Clean Water Act Section 401 water quality certification would be required if an ACOE permit were required or if



the project were to involve filling of or work in Waters of the State. The project will require coverage under the SWRCB construction general permit (including preparation of a stormwater pollution prevention plan) if it involves one acre or more of ground disturbance. CDFW requires a Lake and Streambed Alteration (LSA) Agreement when it determines that the activity, as described in a complete LSA Notification, may substantially adversely affect existing fish or wildlife resources. LSA Notification would be required if any project element involves work in a CDFW-jurisdictional watercourse or ditch (or its associated riparian vegetation). The project appears to be located entirely within the "Appeal" portion of the Coastal Zone. Therefore the project would require a coastal development permit (CDP) from the County of Humboldt. Which would be appealable to the California Coastal Commission (CCC). Alternatively, if the project includes areas within the CDP jurisdiction of both the County and the State (CCC), then the CDP process would be consolidated to the CCC resulting in a single CDP. The California State Lands Commission's (CSLC) jurisdiction includes the State's tide and submerged lands that extend from the shoreline out to three miles offshore. A CSLC lease is in place with the HBHRC.

6.1.6 Collection System Construction Issues

Shallow groundwater, loose sandy soils, relatively flat topography, and high seismic activity in the vicinity of Fairhaven create a challenging environment for a gravity sewer system. A gravity system must maintain minimum slopes to maintain proper flow, and long pipe runs continually get deeper. A gravity pipe is not typically full of water, creating more buoyancy than in a pressure pipe, and increasing the risk of the pipe floating or moving, especially during a seismic event that results in liquefaction of soils. Gravity pipes are also not as water tight as pressure pipes, increasing the opportunity for groundwater infiltration into the collection system, especially when submerged, increasing peak flow rates in the system. Shoring of deep trenches in loose sandy soils increases the cost and danger associated with construction. If groundwater is above the invert of the trench depth during construction, extraction wells can be installed in the vicinity of the trench to draw groundwater levels down to prevent trench flooding. The depth, location of extraction wells will require analysis of soil transmissivity and groundwater levels relative to proposed trench depths.

Sewer pipes do not exist in Fairhaven, so they have to be placed to avoid existing utilities, including water and gas piping. Sewer pipe must maintain a minimum of 1 foot of vertical separation below water pipes, and gas piping at all times, maintaining a minimum of 1 foot of vertical separation. Water and gas piping is assumed to be 3 feet deep at the pipe invert; adding 1 foot for separation and 6 inches for the diameter of the sewer pipe brings the minimum depth of the sewer pipe invert to 4.5 feet. An additional 6 inches is added for a safety factor to account for unknown conditions in the field, such that the minimum sewer pipe depth at water and gas pipe crossings is assumed to be 5 feet. In other areas, where the minimum sewer pipe depth is not constrained by water or gas pipes, it was assumed that the lateral invert depth and slope were the limiting factors. Assuming the residential end of the lateral is approximately 2 feet deep, extends 100 feet to the sewer main at a slope of 0.5%, and drops another 6 inches at the connection, the minimum sewer main invert depth due to laterals is also 4.5 feet. Adding another 6 inches to account for unknown field conditions, the minimum sewer main invert depth due to laterals is also 5 feet.



6.1.7 Collection System Opinion of Probable Cost

Gravity Sewer Opinion of Probable Cost

Table 6-4 includes the total opinion of probable cost for a combination gravity and pressure sewer system for the PCSD service area. Costs for the pressure main south of Fairhaven that would serve the boat ramp and campground, the Oyster Beach Resort, and the Airfield are listed separately so that segment of the system can be included as an alternative to the project. The construction subtotal for this section of pipe is \$940,000 (including 12% for mobilization).

Table 6-4: Opinion of probable project cost for gravity sewer system.

| Item Description | Quantity | Units | Unit Cost | Total Cost |
|--|----------|-------|-----------|--------------------|
| Pump Station - Fairhaven | 1 | EA | \$130,000 | \$130,000 |
| Pump Station - Finntown | 1 | EA | \$100,000 | \$100,000 |
| Laterals, Main to Right-of-Way | 76 | EA | \$2,000 | \$150,000 |
| Gravity Main – Deep Trench | 4,740 | LF | \$110 | \$520,000 |
| Gravity Main – Shallow Trench | 2,860 | LF | \$90 | \$260,000 |
| Pressure Main – South of Fairhaven | 5,000 | LF | \$80 | \$400,000 |
| Pressure Main – All Else | 10,600 | LF | \$80 | \$850,000 |
| Gravity Main Trench Dewatering | 7,600 | LF | \$65 | \$490,000 |
| Pressure Main Trench Dewatering – South of Fairhaven | 5,000 | LF | \$30 | \$150,000 |
| Pressure Main Trench Dewatering – All Else | 10,600 | LF | \$30 | \$320,000 |
| Gravity Main Surface Restoration | 60,800 | SF | \$12 | \$730,000 |
| Pressure Main Surface Restoration – South of Fairhaven | 20,000 | SF | \$12 | \$240,000 |
| Pressure Main Surface Restoration – All Else | 42,400 | SF | \$12 | \$510,000 |
| Pressure Main Cleanouts – South of Fairhaven | 4 | EA | \$10,000 | \$40,000 |
| Pressure Main Cleanouts – All Else | 26 | EA | \$10,000 | \$260,000 |
| Valves – South of Fairhaven | 4 | EA | \$2,500 | \$10,000 |
| Valves – All Else | 6 | EA | \$2,500 | \$20,000 |
| Mobilization (12%) | 1 | LS | \$620,000 | \$620,000 |
| Construction Subtotal | | | | \$5,800,000 |
| Permitting (5%) | | | | \$290,000 |
| Engineering Design and Construction Phase Services (20%) | | | | \$1,160,000 |
| Geotechnical (5%) | | | | \$290,000 |
| Contingency (20%) | | | | \$1,160,000 |
| Legal, Administration (5%) | | | | \$290,000 |
| Total Project | | | | \$8,990,000 |

O&M costs for the proposed gravity sewer system include annual cleaning of the two proposed pump stations in Fairhaven and Finntown, regular camera inspection of gravity pipes, regular jet



cleaning of gravity pipes, and power to run the pump stations (Table 6-5). Camera inspection and jet cleaning are assumed to take place simultaneously because jetting is often required prior to camera inspection. Initially, cleaning and inspection of the new sewer system may not be necessary, but over the lifetime of the system it is assumed that 10% of the piping will be cleaned and inspected annually (760 feet per year). Note that the cost of jet cleaning gravity sewer pipes will vary depending on the amount of material present in the pipes.

Table 6-5: Opinion of probable operation and maintenance cost for gravity sewer system.

| Item Description | Quantity | Units | Unit Cost | Total Cost |
|--------------------------------|----------|-------|-----------|----------------|
| Pump Station Cleaning | 2 | EA | \$700 | \$1,400 |
| Gravity Main Jet Cleaning | 760 | LF | \$2 | \$1,500 |
| Gravity Main Camera Inspection | 760 | LF | \$1 | \$800 |
| Pump Station Power Cost | 12 | LS | \$450 | \$5,400 |
| Total Annual O&M | | | | \$9,000 |

Pressure Sewer Opinion of Probable Cost

Table 6-6 includes the opinion of probable cost for a complete pressure sewer system for the PCSD service area. As mentioned previously, the subtotal for length of pipe south of Fairhaven has been broken out separately. The construction subtotal for this segment of pressure main is \$940,000 (including 12% for mobilization).

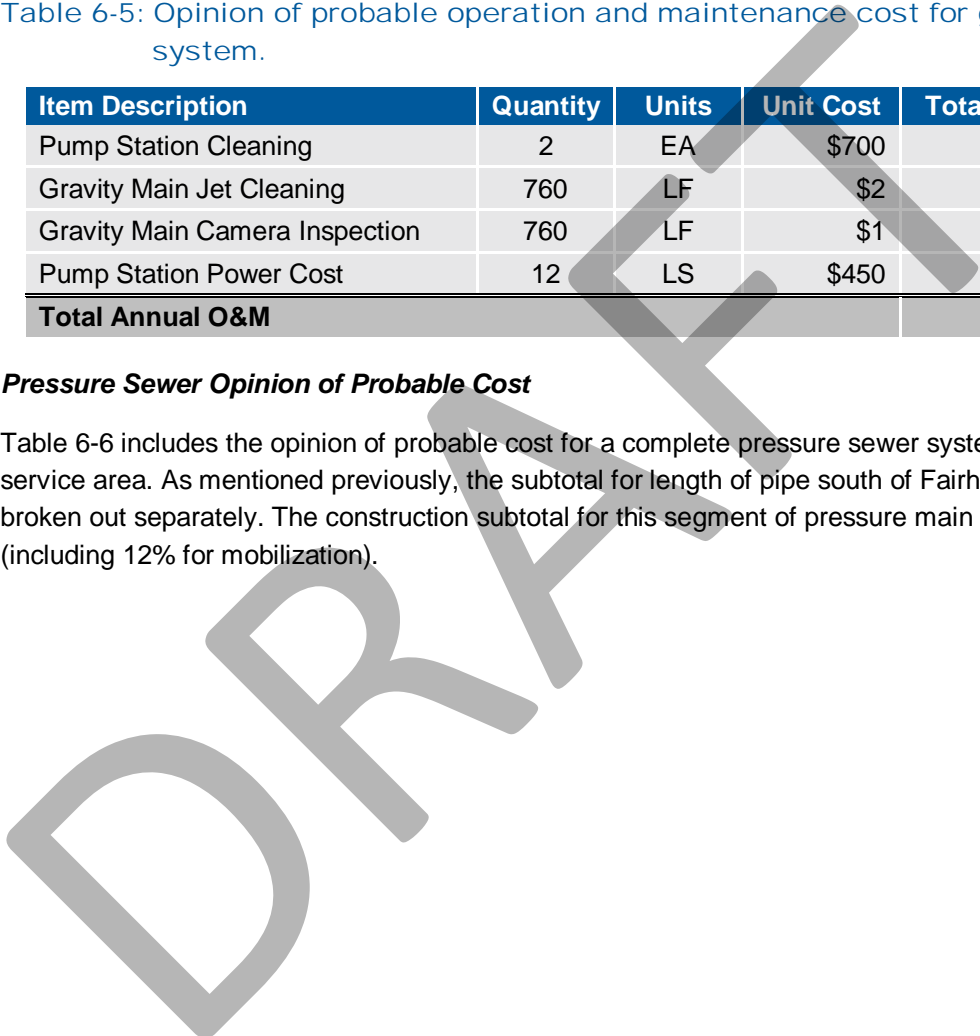



Table 6-6: Opinion of probable project cost for pressure sewer system.

| Item Description | Quantity | Units | Unit Cost | Total Cost |
|---|----------|-------|-----------|--------------------|
| Residential Pump Stations | 76 | EA | \$10,000 | \$760,000 |
| Laterals, Main to Right-of-Way | 76 | EA | \$1,500 | \$110,000 |
| Trenching/Piping/Backfill – South of Fairhaven | 5,000 | LF | \$80 | \$400,000 |
| Trenching/Piping/Backfill – All Else | 16,700 | LF | \$80 | \$1,340,000 |
| Trench Dewatering – South of Fairhaven | 5,000 | LF | \$30 | \$150,000 |
| Trench Dewatering – All Else | 16,700 | LF | \$30 | \$500,000 |
| Trench Surface Restoration – South of Fairhaven | 20,000 | SF | \$12 | \$240,000 |
| Trench Surface Restoration – All Else | 66,800 | SF | \$12 | \$800,000 |
| Pig Launching/Receiving/Valving Stations – South of Fairhaven | 4 | EA | \$10,000 | \$40,000 |
| Pig Launching/Receiving/Valving Stations – All Else | 26 | EA | \$10,000 | \$260,000 |
| Valves – South of Fairhaven | 4 | EA | \$2,500 | \$10,000 |
| Valves – All Else | 14 | EA | \$2,500 | \$40,000 |
| Mobilization (12%) | 1 | LS | \$560,000 | \$560,000 |
| Construction Subtotal | | | | \$5,210,000 |
| Permitting (5%) | | | | \$260,000 |
| Engineering Design and Construction Phase Services (20%) | | | | \$1,040,000 |
| Geotechnical (5%) | | | | \$260,000 |
| Contingency (20%) | | | | \$1,040,000 |
| Legal, Administration (5%) | | | | \$260,000 |
| Total Project | | | | \$8,070,000 |

Annual O&M of the proposed pressure sewer system includes maintenance of the small residential grinder pump systems. This cost is estimated to be approximately \$200 per unit per year (Molatore, 2016; Table 6-7). Molatore (2016) indicates that an average service visit frequency for a grinder pump sewer system is once every 3-5 years, and that an average service visit duration is approximately 1.5 hours. Pressure sewer systems will include repair and replacement of the residential grinder pump system components including float switches and grinder pumps. One manufacturer reports a repair frequency of 8-10 years at an average repair cost of \$500, and a replacement frequency of 20 years with a replacement cost of \$2,300 (Molatore, 2016).

Residential grinder pump systems may be supplied electricity by individual homes, and power costs will be paid for by individual homeowners directly such that this cost is not included in the O&M costs for the whole system. Grinder pumps are estimated to be approximately 1.5 hp, assumed to run for a total of 1 hour per day, at a cost of \$0.12 per kilowatt-hour (kWh) for a total power cost for each system of \$4.03 per month.

O&M costs for pigging the pressure sewer are not included in this project cost estimate because cleaning of the pressure sewer may not ever be required. Water velocity in the pipes should prevent



accumulation of material; however, if the system is sized for the full project buildout and buildout never occurs for some reason, design velocities may not be obtained, and material may accumulate in the pipes. If this occurs, pressures will increase, and cleaning will be required.

Table 6-7: Opinion of probable operation and maintenance cost for pressure sewer system.

| Item Description | Quantity | Units | Unit Cost | Total Cost |
|---|----------|-------|-----------|-----------------|
| Grinder Pump Pressure Sewer Maintenance | 76 | EA | \$200 | \$15,000 |
| Total Annual O&M | | | | \$15,000 |

Table 6-8: Opinion of probable lifecycle cost for sewer collection system alternatives.

| Item | Alternative 1: Gravity Sewer System | | Alternative 2: Pressure Sewer System | |
|----------------------------------|--|--------------------|---|--------------------|
| | Value | Present Value | Value | Present Value |
| Construction Costs | \$5,800,000 | \$5,800,000 | \$5,210,000 | \$5,210,000 |
| Soft Costs | \$3,190,000 | \$3,190,000 | \$2,860,000 | \$2,860,000 |
| Annual O&M Costs | \$9,000 | \$420,000 | \$15,000 | \$700,000 |
| 30-yr Total Present Worth | - | \$9,410,000 | - | \$8,770,000 |

6.1.8 California Government Code Section 65041.1

The range of collection system alternatives considered in this document addresses the state planning priorities in California Government Code Section 65041.1 as follows:

- a. The project focuses on serving existing residences, commercial and industrial facilities, and public recreation areas, as well as parcels with infill development capacity within the project area. Legal parcels outside the existing developed areas may become sewered in the future; however, permitting challenges associated with placing pipe in undeveloped areas, and similar challenges associated with new home construction in these areas, have excluded them from the initial phase of development considered in this study. The cultural resources analysis (and mitigation, if appropriate) required as part of the CEQA process and pursuant to the various permitting processes, as well as the proposal to install all collection system piping within existing roads, will ensure that cultural and historical resources are identified and preserved during project design and development.
- b. The collection system alternatives protect environmental resources, such as, wetlands, wildlife habitats, ESHAs, recreation lands, and open space, by locating the proposed collection system piping within existing roadways and minimizing impacts to undeveloped land. The project site does not contain farm, range, or forest lands. With the alternatives analysis process and the imposition of mitigation measures and conditions of approval respectively, the CEQA and permit processes will ensure that the project adequately protects environmental resources.



- c. The collection system alternatives encourage efficient development patterns by focusing on serving existing residences, commercial and industrial facilities, and public recreation areas, as well as parcels with infill development capacity within the project area. The focus on infill promotes the efficient use of land and development adjacent to existing developed areas. The areas to be served by the project are appropriately planned, although the Local Coastal Plan will require revisions to ensure the correct zoning for the development proposed. These areas are already served by existing roadways and other essential utilities and services. The project will minimize ongoing costs to taxpayers by encouraging infill development.

6.1.9 Climate Change Considerations

The Samoa Peninsula is perhaps the most vulnerable to climate change effects due to sea level rise (SLR). The PCSD service area varies in elevation from sea level to a maximum of approximately 40 feet (NAVD88). The primary impacts from sea level rise are increases in flooding and erosion, and increased tsunami inundation hazards. As required by the CCC permitting process and the EIR process, the project will account for potential effects related to flooding, erosion, and tsunami, including the potential increase in these threats related to climate change and sea level rise.

A wide range of global and regional SLR projections exist from various sources using various modeling approaches and assumptions that are too numerous to list here. In 2015, Northern Hydrology and Engineering prepared a local SLR modeling and vulnerability mapping report detailing the current local SLR projections for Humboldt Bay. In particular it is important to consider not only SLR in Humboldt Bay, but also vertical land motion (VLM) due to tectonic movement. When these two phenomena are combined, the relative SLR (RSLR) projections for Humboldt Bay are greater than those for many other areas due to the downward motion of the ground (approximately - 2.33 millimeters per year at the North Spit of Humboldt Bay). Accounting for VLM, the RSLR projections for the North Spit of Humboldt Bay on the Samoa Peninsula include approximately 7 inches by 2030, 13 inches by 2050, and 39 inches by 2100 (NHE, 2015).

In addition to RSLR considerations on the Samoa Peninsula, it is also important to consider the effects on groundwater. The freshwater aquifer that exists on the peninsula sits atop a deeper saltwater influenced layer of water, mounding as it infiltrates into the sandy spit. As sea level rises, the mounded groundwater is also expected to rise proportionally which will impact any buried infrastructure on the peninsula.

6.1.10 Opportunities for Water and Energy Efficiency

Water and energy efficiency in wastewater collection and conveyance systems starts with water conservation in the home to reduce water consumption and wastewater production, and also includes sewer design and construction.

In the Home

Design flow rates for the PCSD wastewater systems were developed based on the assumption that water consumption has decreased over the last few decades due to the installation of more water efficient appliances and increasing consciousness surrounding water conservation. While a number of the existing homes in Fairhaven and Finntown may have older, less efficient appliances, newer



homes are expected to install more efficient appliances when they are built. PCSD can also help to establish financial incentives for replacement of older appliances in existing homes including low-flow toilets, taps, and showerheads. Decreasing wastewater production in the home reduces the amount of energy required for pumping and treatment in the sewer system. Reduction of water use can also result in an increase in pollutant concentrations in wastewater, which can have a similar increase in biological treatment efficiency, resulting in additional energy savings and improved water quality.

In the Ground

In a gravity collection system, one of the major contributors to peak flows is infiltration of groundwater into aging pipes and joints. One of the major benefits of constructing a new sanitary sewer collection and conveyance system is that the entire system will be constructed of modern materials using modern design and construction standards. This will result in a significant reduction in infiltration of groundwater into the gravity sewer system, significantly reducing costs associated with pumping and treatment. Groundwater infiltration can result in significant reductions in treatment efficiency due to dilution of pollutant concentrations and high flow rates.

Pressurized sewer systems significantly reduce potential groundwater infiltration in the collection system, which can result in decreased pumping and treatment costs compared with a gravity collection system.

Demand Response

Slightly more abstract is the concept of demand response relating to energy efficiency. This refers to a smart grid capable of scheduling electrical demand during times of day when the overall electrical use on the grid as a whole is reduced, such as, night time. This reduces electrical demand during peak hours that results in the use of power plants with lower efficiency called *peaker plants*. If Fairhaven and Finntown construct a pressure sewer system with individual pump stations at each home, consisting of a full buildout of 152 individual pump stations, the system may benefit from the energy efficiency of a smart grid enabled management system. Programming pumping stations to stay off until a certain time would likely require added storage capacity to ensure the systems do not overflow in the case of power outages, or delayed pumping.

The concept of demand response is being developed for experimental micro-grid systems right here in Humboldt County by the Schatz Energy Research Laboratory (SERC) at Humboldt State University (HSU) for the Blue Lake Rancheria. There is a possibility for grant-funded collaboration to enable the use of smart-grid technology for demand response to a pressure pumping system on the peninsula.

6.1.11 Comparison of Collection System Alternatives

The advantages and disadvantages of each collection system alternative were developed and are presented in Table 6-8. Both monetary and non-monetary factors were considered in the development of this table.

Table 6-8: Advantages and disadvantages of treatment alternatives

| Collection System | Advantages | Disadvantages |
|-------------------|---|--|
| Gravity | <ul style="list-style-type: none"> • Low power requirements. • Low maintenance required. • Low O&M costs. • Minimal number of pump stations decreases O&M. | <ul style="list-style-type: none"> • Risk of significant damage during earthquake events. • High potential for I/I. • Increased potential for groundwater impacts. • Deeper pipes required to maintain minimum slopes; results in more costly construction. • Maintenance includes regular camera inspection and jet cleaning. |
| Pressure | <ul style="list-style-type: none"> • Reduced risk of significant damage during earthquakes. • Shallow pipe network reduces cost/complexity of trenching during construction. • Shallow pressurized pipes prevent infiltration of groundwater from entering system, which can reduce the cost of treatment. • GP systems: reduce particle size of solids and debris, reducing need for screening at WWTP. • STEP systems: remove solids and BOD, reducing loading to WWTP which can result in a decrease in treatment costs. • Pumping power costs can be paid directly by individual homeowners, reducing administrative costs. | <ul style="list-style-type: none"> • GP systems: Individual small grinder pump systems at each home can result in more frequent system maintenance, increasing the overall O&M cost for the system. • STEP systems: requires periodic sludge pumping of septic tanks, which significantly increases the O&M cost of a pressure system. • STEP systems: septic tanks increase capital cost of new system construction and encumbers land. • Valve or pipe failures can result in large sanitary sewer overflow events. • During extended power outages, operators may have to use a portable generator to pump each individual residential pump station. |

The recommended collection system is the gravity collection system with the pressure main connecting each town to the centralized WWTP. While the capital costs of a gravity sewer system are higher than for the pressure system (Table 6-8), the PCSD may qualify for up to 100% grant funding for construction of the system, pushing the focus of the long-term system costs onto system O&M costs. Annual and O&M costs for the gravity collection system include periodic camera inspection and cleaning of the gravity pipes, in addition to maintenance of the pump stations located at Fairhaven and Finntown. Annual O&M costs for the pressure system include maintenance of numerous small individual residential pump stations which can require a significant amount of maintenance as the system ages.

6.2 Wastewater Treatment System

6.2.1 Treatment System Description

Wastewater treatment processes are generally divided into three levels, depending on the level of treatment afforded by them. The following is a brief description of the types of treatment processes that fall into these levels:

- **Primary treatment** - This is an initial process or series of processes that physically remove large solids, generally by screening or gravity settling. This step also serves to protect the equipment within the treatment plant by removing oversized materials, like trash, rags and rocks, from affecting the performance of the treatment process.
- **Secondary treatment** - This is generally a biological process that converts organics in the wastewater into a form that can be removed by settling or are consumed by microorganisms contained within the treatment process that can then be removed by settling. Typical types of secondary treatment processes include facultative or aerated ponds, activated sludge or trickling filters. Essentially the process creates an environment where a concentration of different microorganisms can grow, using the wastewater as a food source, thereby purifying the wastewater. Secondary treatment is typically the minimum treatment level required for most municipal wastewater systems. Advanced secondary treatment includes modifications to the biological process such that nutrients (mainly nitrogen and possibly phosphorus) are removed.
- **Tertiary treatment** - This is typically a filtration step, where the solids in the secondary treated wastewater are separated from the wastewater by passing through a fine filter. The filter media can be sand, textile or a membrane. Tertiary treatment is not always necessary or required for all applications, see sections 6.2.2 and 6.2.3 below for additional information.

Additional process considerations beyond the treatment levels include:

- **Disinfection** - This is a final step in the treatment of the liquid portion of the wastewater, and it is used to remove bacteria and other harmful organisms prior to discharge (disposal). The most common disinfection method mixes some form of chlorine with the wastewater for at least 30 to 60 minutes. Improvements in technology have made use of Ultraviolet (UV) light another cost effective and popular method of disinfection.
- **Solids treatment** - Depending on the type of treatment processes used, various types of sludge are formed and removed from the treatment process. These require additional processing to stabilize the solids to a level that makes them acceptable for disposal or reuse. See Section 6.4 below for additional information on solids treatment.

The wastewater treatment process produces treated water, or effluent, which must be disposed of. The level of treatment of the effluent water that is necessary during the treatment process depends on the final disposal method, and the required level of treatment increases with the potential for contact of the effluent by the public. There are essentially three options for disposal:

1. Land disposal through either a subsurface leachfield or a surface spreading basin or rapid infiltration basin (also called a percolation pond)



2. Reuse as irrigation to grow either a crop or at a site that needs to be irrigated, such as, a golf course. If used on a crop, it should be one that requires further processing, such as, wine grapes, fruit trees, or hay for animal feed (and not one that is consumed directly, such as most vegetables).
3. Discharge to surface water, such as, a creek, river, or ocean.

Two ROWDs have been submitted to the NCRWQCB for the disposal of the Town of Samoa's treated wastewater effluent for both leachfield disposal and ocean discharge. Although neither has been approved, conversation with the NCRWQCB staff has indicated that the concerns related to potential groundwater impacts require tertiary treatment for land disposal of effluent, possibly to the level afforded by reverse osmosis (RO). Discharge to the ocean, through the RMT-II outfall, has the least restrictive treatment requirement of secondary treatment. See Section 6.3 for additional information on wastewater disposal.

6.2.2 Treatment System Alternatives

The following three secondary treatment alternatives were considered for this project:

1. Sequencing batch reactor (SBR)
2. Advantex process
3. Recirculating gravel filter (RGF).

For tertiary treatment only reverse osmosis (RO) was considered, because talks with the NCRWQCB have indicated that RO is the preferred method for land disposal on the Samoa peninsula. For disinfection, both chlorine and UV systems are considered. The following subsections contain a description of each of the treatment system alternatives.

6.2.2.1 Sequencing Batch Reactor

SBRs are a modification to the activated sludge process, which is the standard process used to achieve secondary treatment. Conventional activated sludge facilities typically rely on multiple basins while SBR systems combine all of the treatment steps and processes into one basin (Figure 6-7). This is accomplished by controlling the level of liquid and providing aeration.

SBR operation is based on a five-step cycle:

1. **Fill:** the basin is filled with influent wastewater. The influent creates an environment for biochemical reactions by bringing consumables to the microbes in the activated sludge. Mixing and aeration can occur during the filling process.
2. **React:** no wastewater enters the basin during this step, while mechanical mixing and aeration units are activated. Carbonaceous BOD and phosphorus are taken up during this phase by the microbes.
3. **Settle:** aeration and mixing cease, and activated sludge is allowed to settle.
4. **Decant:** after settling is complete, the clear supernatant effluent is decanted.

5. Idle: after decanting and before the next filling phase, a small amount of activated sludge is pumped out of the bottom of the basin.

Primary treatment in the form of screening and grit removal must occur before the five-step process mentioned above. There are several manufacturers that make equipment for this process and complete SBR treatment plant packages can be obtained from several manufacturers.

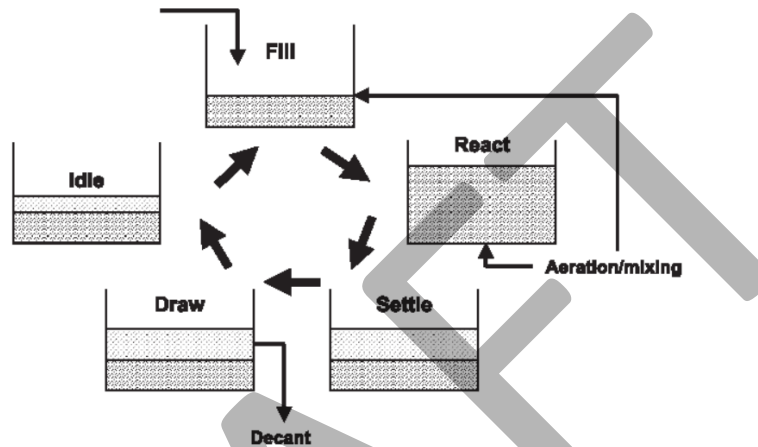

Figure 6-7: Overview of the typical SBR process

A Grade III licensed operator would be required to operate and maintain an SBR system operating at 60,000 gpd. The operator must have adequate knowledge about SBR systems to correct any problems with the facility, if they occur.

6.2.2.2 AdvanTex

The AdvanTex process is a proprietary technology that uses a textile membrane for the filtration process. Primary treatment is provided by a community septic tank, and septic tank effluent then enters a two-compartment processing tank. In the first compartment, the septic tank effluent separates into three zones: 1) a sludge layer, 2) a scum layer, and 3) a clear layer. Effluent from the clear layer flows into the second compartment of the tank through holes in the tank's baffle wall. A proprietary Biotube pumping package in the second compartment then pumps the filtered effluent to a distribution manifold in the AdvanTex pod. This effluent then percolates through the textile membrane media and is collected at the bottom of the filter basin by a drain pipe. The drain pipe returns the treated water to the recirculating splitter valve (RSV), where it is then split between the processing tank and the final discharge.

The pump in the second compartment typically doses the filter 72 times a day for short periods (usually less than 30 seconds). This “microdosing” process optimizes treatment and occurs 24 hours a day to maintain a proper biological environment.

AdvanTex units are designed to meet effluent ammonia levels of 2 mg/L or less, and they can be coupled with an upflow filter to meet total nitrogen requirements of less than 10 mg/L.

An AdvanTex system would require a Grade II operator that must also be certified by Orenco Systems, Inc. to operate and maintain the facility.

6.2.2.3 Recirculating Gravel Filter

A recirculating gravel filter system is a non-proprietary system that uses a community septic tank for primary treatment. A general flow diagram of this process is presented in Figure 6-8. After the initial settling of solids, the pre-treated wastewater flows to a recirculation tank and is applied uniformly to gravel filters in small doses, to alternately rest and load the gravel media. The application of wastewater to the filter media results in the development of a thin film of microorganisms, similar to a trickling filter. As the wastewater percolates down through the gravel filter, it comes into contact with this film. The slow-growing organisms that compose the film can exhibit very good rates of BOD, and suspended solids removal. In addition, the process is very effective at converting ammonia to nitrate. The filtered wastewater is contained at the bottom by an impermeable liner, and the filtrate is collected by an underdrain. The filtrate is then piped back to the recirculation tank, from which the flow is split. To achieve denitrification, some of the flow is returned to the beginning of the septic tank. When the recirculation tank is full, a control valve is closed, and the rest of the treated effluent flowing from the filter is discharged.

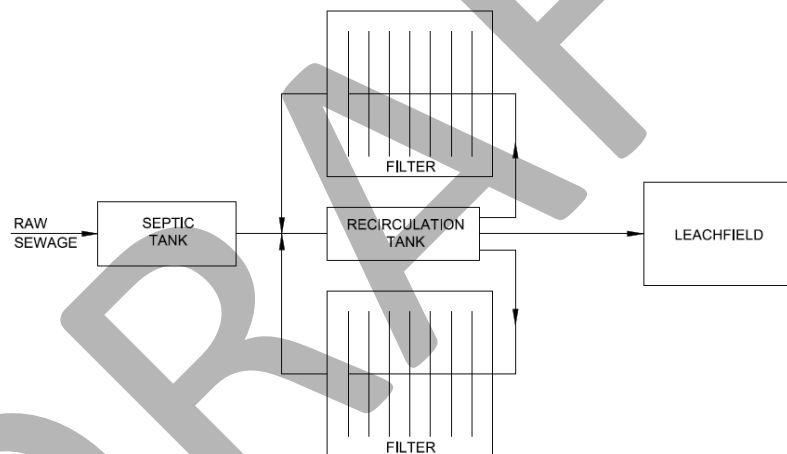

Figure 6-8: General flow diagram of recirculating gravel filter system

This process has been implemented in the community of Weott, and the community of Miranda has a similar facility that uses sand as the media instead of pea gravel. Both of these systems are of similar size that would be required for the Samoa Peninsula system and have produced excellent quality effluent for more than 25 years (Miranda was constructed in 1980 and Weott in 1990.) The advantage of pea gravel is that it can be locally sourced, while the filter sand has to come from Monterey, because the local sand has too many fines.

An RGF treatment system operating at 60,000 gpd would require a Grade II operator to operate and maintain the system.

6.2.2.4 Reverse Osmosis

As previously mentioned, staff at the NCRWQCB have mentioned that in order to discharge wastewater to a leachfield, the wastewater would require treatment to drinking water levels through a tertiary treatment system similar to a Reverse Osmosis (RO) system. That is the only reason that RO treatment is considered here.

RO consists of a fine semi-permeable membrane that only allows water molecules to pass through. RO is an energy-intensive process due to the high pressure required to “push” the water against the concentration gradient. The RO system would require primary and secondary treatment prior to the RO unit, and the RO system would provide tertiary treatment. There are two main RO design types, spiral-wound (Figure 6-9) and hollow fiber (Figure 6-10). Both designs have high-pressure source water enter and pure water exit. The high pressure required for RO to work can make operating costs high. There is no backwash cycle for the RO process, meaning that source water must enter with a turbidity below 1 NTU to avoid clogging the feed channel. This will be exceptionally difficult to obtain in a wastewater treatment process and likely would require an additional pre-filtration unit prior to the RO membranes. Disinfection of the source water can also help prevent biological fouling of the RO membranes. The RO process will also produce a concentrate stream that will require disposal (note: the concentrate will be higher in dissolved solids and salts than the permeate water). The NCRWQCB will likely not allow this to be disposed of in a leachfield and will likely require it to be diluted before disposal in the ocean outfall or by some other method. The concentrate stream is typically 20 to 50% of the flow of the original feed stream. RO membranes typically need to be replaced every 2 to 3 years.

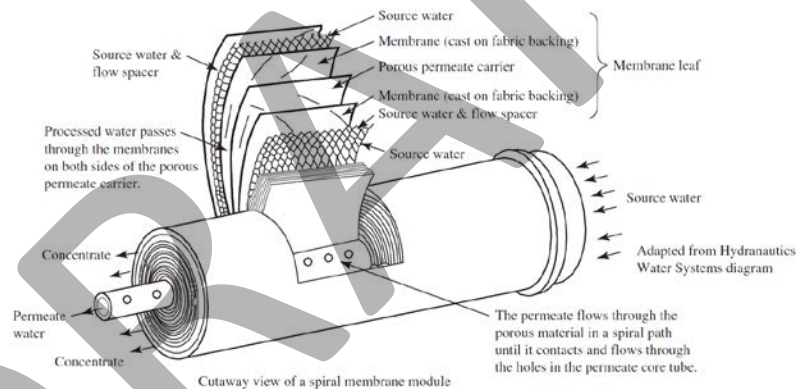

Figure 6-9: Typical spiral-wound RO membrane module (Davis, 2010).

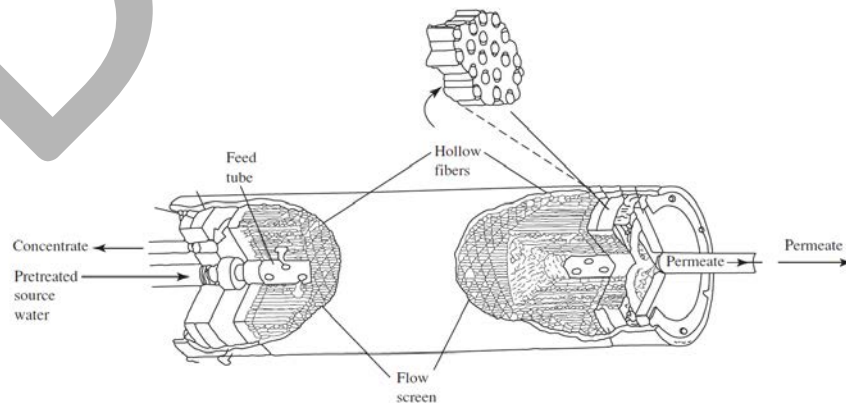

Figure 6-10: Typical hollow fiber RO membrane module (Davis, 2010).



6.2.2.5 Chlorine Disinfection

Chlorine disinfection is the most common form of disinfection for treated wastewater effluent. After secondary treatment, the wastewater passes a chlorine feed pump that feeds a solution of chlorine into the treated effluent stream. The effluent then enters a contact basin to allow time for the chlorine reactions to finish disinfecting the water. Chlorine can be stored as a gas, liquid, or solid. Chlorine gas is a strong oxidant and is very reactive, requiring extra safety precautions. Liquid sodium hypochlorite and solid calcium hypochlorite tablets are most commonly used for smaller systems.

When chlorine mixes with organic materials there is always the risk of producing trihalomethanes (THM), which are toxic to aquatic life. To reduce this risk it is important that the secondary treatment be calibrated to produce the correct ratio of ammonia to total chlorine added.

6.2.2.6 Ultraviolet Disinfection

Although less popular due to its higher energy and lamp replacement costs, UV disinfection is slightly more effective than chlorine disinfection if operated and maintained correctly. After secondary treatment, the water would pass by a UV lamp bank as it exited the treatment plant for disposal. As a physical process, the UV light “touching” the pathogens is what accomplishes the disinfection. Therefore, it is important that TSS levels be consistent and low enough to allow proper transmittance of UV light. Secondary treatment is the minimal treatment level requirement for effective UV disinfection. Additionally, the UV lamps themselves must be regularly wiped to keep the lamps clear in order to effectively transmit their light. UV systems can be fitted with automated wipers to keep lamps clean. UV disinfection produces no harmful by-products. UV lamps need to be replaced every one to two years. Beyond lamp maintenance there are minimal operator needs.

6.2.3 Treatment System Design Criteria

As discussed in Section 5, the base sanitary flow for the PCSD is 60,000 gpd. With full build-out of the peninsula, in 30 or more years, the base sanitary flow could be 200,000 gpd. A peaking factor of 4.0 was used to arrive at a design peak hour flow (highest hourly flow during the wet season) of 240,000 gpd, increasing to 760,000 gpd with full peninsula build-out.

The level of treatment required for this facility will be governed by the requirements and approval of the NCRWQCB, who is the primary regulatory authority. All publically owned treatment works are required to meet secondary treatment standards using technology based effluent limitations (40 CFR part 133). The secondary treatment standards are monitored for three parameters: 5-day biochemical oxygen demand (BOD₅), total suspended solids (TSS), and pH. The parameter limits are listed below.

- BOD₅ and TSS
 - The 30-day average shall not exceed 30 mg/L.
 - The 7-day average shall not exceed 45 mg/l.
 - The 30-day average percent removal shall not be less than 85%.
- pH
 - The pH shall be maintained within the limits of 6.0 to 9.0.



This study assumed a raw sewage concentration of 200 mg/L for BOD₅ and 195 mg/L for TSS, 85% removal would result in an effluent with an average concentration of 30 and 29 mg/L, respectively. Beyond secondary treatment standards the effluent must meet further treatment requirements based on the effluent disposal method as follows:

1. Land Disposal: According to the North Coast Basin Plan and conversations with the NCRWQCB staff, given the high water table and lack of separation to groundwater, land disposal effluent must meet USEPA primary drinking water standards (Appendix E). To meet these standards the treatment system will require tertiary treatment and disinfection.
2. Ocean Disposal: The RMT-II ocean outfall releases effluent 1.5 miles offshore, putting it under the jurisdiction of the California Ocean Plan. Ocean disposal will require secondary treatment to meet disposal requirements. Although disinfection is not required beyond 1,000 feet from shore, it is recommended, because people are known to crab and fish in the vicinity of the outfall. The California Ocean Plan disinfection standards for shellfish harvesting are as follows:
 - The median value of total coliform bacteria shall not exceed a most probable number (MPN) of 70 per 100 milliliters in a calendar month, and
 - No samples shall exceed an MPN of 230 per 100 milliliters

6.2.4 Treatment System Potential Environmental Impacts

A full analysis of potential environmental impacts will be included in the EIR that will be completed prior to completion of the planning phase for this project. All wastewater treatment plants have a potential to generate odors, although modern design and operation should reduce odors to a minimum, and likely to levels where they are not perceived beyond the property line of the treatment plant site. Although odors can be generated in the processing of the liquid portion of the wastewater, the majority of odor generating issues are related to the solids handling processes.

Other potential impacts include noise from pumps and blowers, and visual impacts. These impacts can also be mitigated with proper design. Impacts to ground or surface waters would be mitigated by ensuring the regulatory mandated treatment levels are obtained by the treatment process.

6.2.5 Treatment System Land and Permitting Requirements

Constraints when choosing a project site for a wastewater treatment plant on the Samoa Peninsula are that the project site:

- be zoned Public Facility or Industrial General, not Industrial Coastal Dependent;
- minimize impacts to environmentally sensitive habitat areas (ESHA), such as, wetlands and dunes, both of which exist throughout the open areas of the peninsula;
- be available for purchase or lease for the lifetime of the project;
- minimize operational costs;
- have approximately 3 acres of available space; and
- be north of Fairhaven to facilitate potential use of the RMT-II ocean outfall line.

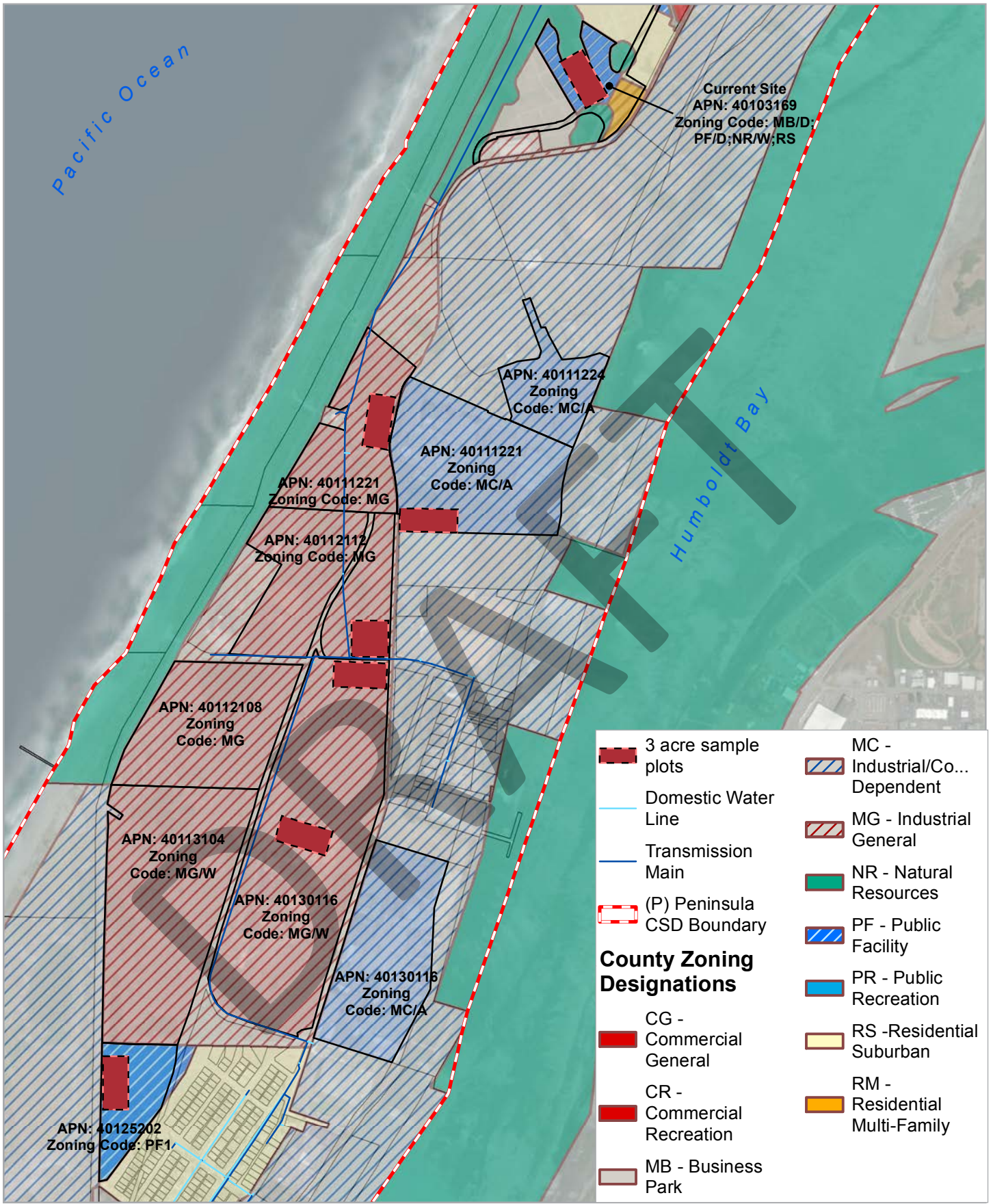

Paper Size ANSI A
 0 0.07 0.14 0.21 0.28
 Miles

Map Projection: Lambert Conformal Conic
 Horizontal Datum: North American 1983
 Grid: NAD 1983 StatePlane California I FIPS 0401 Feet

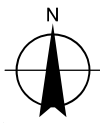

County of Humboldt
 Samoa Peninsula
 Wastewater Planning Study

Project No. 11146487
 Revision No. -
 Date February 2018

Potential Wastewater
 Treatment Sites

FIGURE 6.11

DRAFT



Seven potential sites were identified for evaluation, because they fit the above requirements, except for one site that is improperly zoned, and run along the proposed collection system pathway, see Figure 6-11. The most northern site is the proposed Town of Samoa WWTP which could be designed to treat the entire peninsula's wastewater. Although the Coastal Development Permit for the Samoa townsite would have to be amended as it currently will only allow the treatment of wastewater generated in the Town of Samoa to be treated at this site. As previously stated, the LCP would have to be updated for the construction of any community wastewater system outside the Samoa townsite. The remaining five sites are potentially available for purchase or lease for the plants lifetime. The southernmost site is the easiest to purchase as it is already owned by the Samoa Peninsula Fire District, but it would be difficult and costly to permit as there are known ESHA on site and it is located immediately adjacent to Fairhaven, which would likely lead to public opposition due to perceived odor issues.

All other sites likely face similar environmental permitting challenges except for the site owned by Security National, Inc. on APN 401-301-16. That potential site has been previously developed for use as a soil storage location that is no longer used by the owner. Security National has stated that they would consider the long-term lease of this site for use as a wastewater treatment plant, but they likely would not sell the land to the District.

The sites on APN 401-112-21, which is the RMT-II site, are the closest to the ocean outfall connection at Manhole 5. One of them is zoned appropriately as Industrial General, but the site is on an ash landfill and near both overhead PG&E power lines and underground municipal water lines, making this a poor site choice. The other potential site at that APN is currently zoned Industrial Coastal Dependent, making this an infeasible location, but the process has begun to rezone RMT-II to Industrial General. If the rezoning process is finalized before the final design phase begins in early 2019 it would be prudent to explore placing the plant at RMT-II. There is plenty of previously disturbed (i.e., non-ESHA) land available for purchase or lease at the terminal, and the treatment plant would be closer the ocean outfall pipe, reducing disposal costs significantly, and further from residential sites, reducing odor and noise environmental impacts.

Given the current peninsula zoning, presence of ESHA across the undeveloped portions of the peninsula, and purchase options, consolidating operations for the entire PCSD at the existing Town of Samoa facility is the best alternative. The land has already been approved for use as a WWTP and although the Coastal Development Permit for the site would need to be amended both the design and permitting process has begun for the site.

6.2.6 Treatment System Opinion of Probable Cost

The level of treatment complexity is an important consideration for a small community. Generally, higher levels of treatment and more mechanical processes result in a higher level of complexity. This translates into higher operation and maintenance costs, as the mechanical parts need to be maintained and replaced, and they also generally require more aeration and pumping, resulting in greater electrical costs. The District would also likely need to pay more for higher skilled operators which are harder to retain.

An opinion of probable construction cost, annual O&M cost, and associated present worth was developed for each collection system alternative (Table 6-9). A detailed cost analysis can be found



in Appendix F. (Note: the majority of site preparation costs including mobilization, the control building, yard piping, etc. are included in the secondary treatment system cost estimates.)

Table 6-9: 30-year present worth costs for the treatment system alternatives

| Treatment Type | Secondary | | | Tertiary | Disinfection | |
|------------------------------------|--------------------|--------------------|--------------------|--------------------|------------------|------------------|
| Item | SBR | Advantex | RGF | RO | Chlorine | UV |
| Capital Cost | \$2,630,000 | \$5,070,000 | \$2,420,000 | \$1,600,000 | \$297,000 | \$203,000 |
| Annual O&M Cost | \$150,000 | \$180,000 | \$100,000 | \$110,000 | \$8,000 | \$7,000 |
| 30-yr O&M Present Worth | \$3,480,000 | \$4,170,000 | \$2,320,000 | \$2,550,000 | \$190,000 | \$160,000 |
| 30-yr Total Present Worth | \$6,110,000 | \$9,240,000 | \$4,740,000 | \$4,150,000 | \$490,000 | \$360,000 |

6.2.7 Comparison of Wastewater Treatment System Alternatives

The advantages and disadvantages of each treatment system alternative were developed and are presented in Table 6-10. Both monetary and non-monetary factors were considered in the development of this table.

The recommended treatment system is the SBR system followed by UV disinfection. Although the SBR is more costly than the RGF, it is a more robust system that can ensure the level of treatment required for permitting. Additionally, SBR systems can respond better to changes in flow and a new module can be installed with peninsula build-out. UV disinfection is chosen due to its lack of aquatic toxicity and the high cost of purchasing chlorine for smaller plants.

(Note: if land disposal of effluent is chosen, the treatment system also will need to incorporate the RO tertiary treatment alternative.)

Table 6-10: Advantages and disadvantages of treatment alternatives

| Treatment System | | Advantages | Disadvantages |
|---------------------|----------|--|---|
| Secondary Treatment | SBR | <ul style="list-style-type: none"> • Low capital construction cost. • Can achieve required nitrate and other treatment levels. • Flexible operation to meet changing operational conditions. • Modularity of process allows for expansion. | <ul style="list-style-type: none"> • Mechanical type plant. • Higher O&M costs than an RGF system. • High level operator required. |
| | Advantex | <ul style="list-style-type: none"> • Simple to operate. • Modular, which allows for expansion. • Will likely meet required nitrate levels if an additional nitrification/denitrification step is added. | <ul style="list-style-type: none"> • Units are generally sized for smaller flows. • Proprietary treatment process. • Higher construction and O&M costs. • Nitrate removal not as proven as with SBR system. |
| | RGF | <ul style="list-style-type: none"> • Simple to operate. • Lowest capital and O&M costs. | <ul style="list-style-type: none"> • Nitrate removal not as proven as with other technologies. • Minimal operational flexibility to meet changing operational conditions. |
| Tertiary | RO | <ul style="list-style-type: none"> • Allows for land disposal of effluent. • Will produce high-quality effluent. | <ul style="list-style-type: none"> • High energy costs. • Not necessary with ocean disposal. • RO concentrate still requires disposal in ocean outfall or some other means. |
| Disinfection | Chlorine | <ul style="list-style-type: none"> • Simple to operate. • Effectively kills bacteria. • Low operational costs. | <ul style="list-style-type: none"> • High potential to produce toxic by-products when mixed with ammonia. |
| | UV | <ul style="list-style-type: none"> • Simple to operate. • Small footprint. • No residual. • Effectively kills bacteria, viruses, and cysts. • Energy and lamp replacement costs are comparable to chlorine O&M costs. | <ul style="list-style-type: none"> • Requires low turbidity effluent. |



6.3 Wastewater Disposal

6.3.1 Wastewater Disposal Description

Once the wastewater effluent has been treated, it must be disposed of. This requires some special infrastructure, including a separate pumping, storage, and piping system to return the treated effluent to the natural hydrologic cycle.

For Samoa the discharge will occur on land or into the ocean. Discharge into the ocean would likely occur through the RMT-II ocean outfall pipe. Disposal on land can occur in various ways, including:

1. Subsurface through a community leachfield
2. On the surface through infiltration or flood irrigation basins
3. Irrigation of an agricultural crop or at a lawn space, such as, a golf course

As previously mentioned, the land disposal method would require tertiary treatment of effluent to meet the NCRWQCB Basin Plan standards. However, ocean disposal would only require secondary treatment of effluent.

6.3.2 Wastewater Disposal Alternatives

The two wastewater disposal alternatives are land disposal to a leachfield or ocean disposal through the RMT-II ocean outfall pipe.

Land Disposal

Subsurface infiltration (leachfield) is the most suitable land disposal alternative for the PCSD system. The land requirements for this type are determined by the soil loading and its hydrologic characteristics, as well as required setbacks from property lines and wells. This form of discharge is also restrained by the groundwater levels and proximity to surface waters and drinking waters so the options for its locations are limited. The current Town of Samoa development plan has leachfield disposal areas set aside. These areas are likely of sufficient size to accommodate the full buildout, given that the leachfield areas would not provide treatment, merely disposal.

Alternatives to subsurface disposal include surface infiltration in ponds, flood irrigation, or spray irrigation. Surface disposals (spray and flooding irrigation) require enough surface area and vegetation to ensure that the effluent is being fully infiltrated and does not saturate the soil to a point that it creates ponding. This can be especially difficult during the wet season, so other alternatives are often necessary during those six months. Options during the wet weather season include discharging to waterways or storing excess effluent until it can be disposed on the surface again. Since discharge to the ocean could occur year-round it would be redundant to also develop an above ground land disposal method.

Ocean Disposal

The proposed ocean discharge location is through the ocean outfall located at RMT-II, also known as the former Samoa Pulp Mill. The RMT-II ocean outfall is owned and operated by the Humboldt Bay Harbor, Recreation, and Conservation District (HBHRCD). The HBHRCD has agreed to lease access to the ocean outfall to the Town of Samoa for the discharge of treated municipal



wastewater; however, there is no written lease agreement at this time. A pipeline would be installed from the wastewater treatment plant to the ocean outfall pipe along Vance Road. The pipeline would likely be pressurized and connect to the RMT-II ocean outfall at Manhole 5 (Figure 1-2).

6.3.3 Wastewater Disposal Design Criteria

As discussed in Section 5, the base sanitary flow for the PCSD is 60,000 gpd. With full build-out of the peninsula, in 30 or more years, the base sanitary flow could be 200,000 gpd. A peaking factor of 4.0 was used to arrive at a design peak hour flow (highest hourly flow during the wet season) of 240,000 gpd, increasing to 760,000 gpd with full peninsula build-out.

For ocean disposal, there are minimal site design constraints beyond choosing a treatment location close to the outfall pipe to minimize pumping costs.

For land disposal in a leachfield, there are many constraints to consider for the leachfield site:

- Sufficient size to handle projected flows
- Adequate separations or setbacks from streams, wells, and property lines
- Soil permeability—must be permeable and have at least 15% fines. Because this wastewater will already be treated to drinking water quality, the main function of the leachfield here is for disposal. The more permeable the soils, the smaller the leachfield needs to be.
- Separation from groundwater—a minimum of 5 feet is needed.
- Appropriate setback requirements from property lines, wells, streams, wetlands, etc.
- It must be outside of the 100-year FEMA floodplain or habitats that contain rare or endangered species.
- Distance from the treatment plant site is also a consideration, although it is secondary to those listed above. Locations that are farther from the treatment system would require more conveyance piping, and ultimately a higher construction cost.

Given that the effluent to the leachfield will be treated to drinking water standards, the typical leachfield risks of clogging are avoided, additionally research shows that clean water can be absorbed into the soil at rates 45 to 1,100 times faster than wastewater thereby reducing the leachfield size and recovery time.

6.3.4 Wastewater Disposal Potential Environmental Impacts

A complete analysis of the environmental impacts of this proposed project will be included in the EIR; however, improper wastewater disposal can lead to many public health and environmental issues. The effluent must be treated to specific standards, and it must be disposed of so it does not come into contact with the public or other sensitive environments.

Subsurface disposal (i.e., leachfield) eliminates the potential for direct contact with people or animals. The main environmental risk is from impacts to groundwater. This risk is mitigated by proper design (i.e., separation from groundwater) and operation (i.e., maintaining the system so that it continues to provide the necessary level of treatment). Since the NCRWQCB is requiring



treatment to drinking water standards, these risks are largely mitigated through the treatment process.

Ocean disposal, at 1.5 miles beyond the shore and 80 feet below the water surface, nearly eliminates potential for direct contact with the public and the immediate dilution of treated effluent will protect aquatic organisms. Treated effluent will need to conform to the California Ocean Plan and Waste Discharge Order Requirements. The main environmental risk is fishing in the area; this risk is mitigated by treating and disinfecting the effluent before release. The pipeline from the wastewater treatment plant to the ocean outfall pipe should be installed under the existing roadways to avoid potential impacts to ESHA. Installation of the pipeline under the roadway will impact traffic on the peninsula and should be mitigated with a traffic plan.

6.3.5 Wastewater Disposal Land and Permitting Requirements

The land requirements for leachfields are determined by the soil loading and its hydrologic characteristics, as well as required setbacks from property lines and wells. This form of discharge is also constrained by the groundwater levels and proximity to surface waters and drinking waters so the options for its locations are limited. Humboldt County Department of Environmental Health records show that groundwater levels on the peninsula vary from approximately 3 to 20 feet below ground level (see Figure 4-1) a more in depth groundwater study of each potential site is necessary to determine if there is appropriate vertical space for a leachfield. As mentioned previously to permit leachfields, the NCRWQCB has stated that the water must be treated to drinking water standards through tertiary treatment and disinfection.

The land requirements for ocean disposal are minimal, because the pipeline from treatment to the ocean outfall would be installed underneath existing roadways on the peninsula. To permit the ocean outfall effluent water must be treated through secondary treatment and disinfection is recommended.

6.3.6 Wastewater Disposal Opinion of Probable Cost

An opinion of probable construction cost was developed for a leachfield (Table 6-11) and ocean outfall connection (

Table 6-12) that would handle the design flows of treated wastewater for disposal. It is assumed that site preparation work is covered in the secondary treatment construction costs in Section 6.2.

The leachfield is sized to handle the current flows and would need to be expanded to handle future flows on the peninsula. Included with the leachfield costs are the costs for the tertiary treatment that would be required for permitting of land disposal of wastewater effluent on the Samoa peninsula. The leachfield will require minimal operation and maintenance and annual groundwater monitoring worth approximately \$3,000 annually, while the power, labor, and replacement parts for the reverse osmosis system will cost approximately \$110,000 of operation and maintenance annually.

The ocean outfall pipe is sized to handle the future average wet weather flows. The length of pipe is measured from the proposed Town of Samoa WWTP project site to Manhole #5. It is assumed the pipeline would be pressurized not gravity fed. Being a pressurized line, the ocean outfall will require approximately \$10,000 of energy annually.



Table 6-11: Opinion of probable construction cost for a leachfield including the cost for the tertiary treatment, reverse osmosis system, required for land disposal of effluent on the peninsula.

| Item | Quantity | Unit | Unit Cost | Total Cost |
|--|----------|------|-----------|--------------------|
| 3-inch Solid Pipe | 450 | LF | \$25 | \$10,000 |
| 1.5-inch Perforated Pipe | 6000 | LF | \$10 | \$60,000 |
| Effluent pump station | 1 | EA | \$20,000 | \$20,000 |
| Excavation & Disposal | 210 | CY | \$50 | \$11,000 |
| Pea Gravel | 200 | CY | \$50 | \$10,000 |
| Misc. Valving/Monitoring Wells | 1 | LS | \$70,000 | \$70,000 |
| Finishing Site Work | 1 | LS | \$120,000 | \$120,000 |
| Construction Subtotal | | | | \$300,000 |
| Permitting (5%) | | | | \$20,000 |
| Engineering Design and construction phase services (20%) | | | | \$60,000 |
| Geotechnical (10%) | | | | \$30,000 |
| Contingency (20%) | | | | \$60,000 |
| Total for Leachfield | | | | \$470,000 |
| Reverse Osmosis System ¹ | | | | \$1,600,000 |
| Total for Tertiary Treatment Land Disposal System | | | | \$2,070,000 |
| 1. See Appendix F | | | | |

Table 6-12: Opinion of probable construction cost for an ocean outfall connection.

| Item | Quantity | Unit | Unit Cost | Total Cost |
|--|----------|------|-----------|------------------|
| 6-inch PVC Pipe | 4,000 | LF | \$100 | \$400,000 |
| Paving | 4,000 | LF | \$20 | \$80,000 |
| Effluent Pump Station | 1 | EA | \$120,000 | \$120,000 |
| Misc. Valving | 1 | LS | \$10,000 | \$10,000 |
| Construction Subtotal | | | | \$610,000 |
| Permitting (5%) | | | | \$30,000 |
| Engineering Design and construction phase services (20%) | | | | \$120,000 |
| Geotechnical (5%) | | | | \$30,000 |
| Contingency (20%) | | | | \$120,000 |
| Total | | | | \$910,000 |

Table 6-13 presents the 20-year present worth costs for both disposal systems, note the costs for both the leachfield and tertiary treatment are included with land disposal.



Table 6-13: 30-year present worth costs for the disposal systems.

| Description | Land Disposal | Ocean Outfall |
|------------------------------------|--------------------|--------------------|
| Capital Cost | \$2,070,000 | \$910,000 |
| Annual O&M Cost | \$113,000 | \$10,000 |
| 30-yr O&M Present Worth | \$2,620,000 | \$230,000 |
| 30-yr Total Present Worth | \$4,690,000 | \$1,140,000 |

6.3.7 Comparison of Wastewater Disposal Alternatives

The advantages and disadvantages of each disposal alternative were developed and are presented in Table 6-14. Both monetary and non-monetary factors were considered in the development of this table.

Table 6-14: Advantages and disadvantages of wastewater disposal alternatives

| Disposal Method | Advantages | Disadvantages |
|-----------------|--|--|
| Land Disposal | | <ul style="list-style-type: none"> • Harder to permit. • Requires: <ul style="list-style-type: none"> - tertiary treatment. - expansion with peninsula build-out. - annual groundwater monitoring. • Higher capital cost. • Higher energy costs. |
| Ocean Disposal | <ul style="list-style-type: none"> • Lowers treatment requirements. • Uses existing infrastructure. • Can handle both existing and projected build-out flows. | |

It is recommended that the RMT-II ocean outfall pipe be used for disposal of the wastewater effluent from the proposed Samoa WWTP. Ocean disposal will be much easier to permit and require less treatment than land disposal. Additionally, this disposal method will be able to handle projected flows with full build-out of the peninsula.

6.4 Solids Handling

6.4.1 Solids Handling Description

All of the treatment processes detailed in Section 6.2 generate sludge, which requires additional processing prior to disposal (treated sludge is referred to as “biosolids”). Similar to the liquid portion, the extent of treatment required for these solids is governed by the disposal method. The regulations for the use and disposal of sewage sludge are contained in Part 503 of Title 40 of the Code of Federal Regulations and are regulated by the NCRWQCB. The State of California also



adopted Order No. 2004-0012-DWQ, which provides state-specific requirements for the application of biosolids in California.

With class-dependent restrictions, biosolids may be land applied to forests, agricultural lands, reclamation sites, and public contact sites. The EPA has established two basic classifications of biosolids quality (Class A and Class B). Both classes are safe for land application, but there are additional requirements imposed on Class B biosolids. These include such things as limiting livestock grazing, restricting public access to the application site, and controlling crop harvesting schedules. Class A biosolids are treated to a higher level so that there are no detectable pathogens. "Exceptional Quality" biosolids meet Class A pathogen requirements, vector (flies, mosquitoes, rodents, etc.) attraction reduction standards, and stringent metals limits.

Biosolids must generally meet at least Class B standards in order to be reused or land applied. Sub-Class B biosolids can typically be disposed of at a qualified landfill. For landfill disposal of sludge, the State of California requires that sludge contain at least 20 percent solids (by weight) if primary sludge, or at least 15 percent solids if secondary sludge.

6.4.2 Solids Handling Alternatives

The following solids handling alternatives were evaluated:

- Alternative #1 is to contract a local septic pumping service to pump and dispose of the sludge whenever necessary. The Weott Community Services District (and other small wastewater treatment plants) uses this approach. As mentioned in Section 3.2.4, the Town of Samoa already contracts with Steve's Septic Service in McKinleyville to remove sludge from their existing system.
- Alternative #2 is to dewater the solids using a batch process on-site and then haul the dried solids, or "cake," to either a landfill or composting operation. This would be a process similar to that used by Steve's Septic Service, where the septic tank solids are dewatered and not stabilized further. Similar to Steve's Septic, the District would have to have the dried solids hauled to either a landfill for disposal or to a composting facility.
- Alternative #3 entails the construction of a facultative sludge lagoon and then land applying the stabilized solids as a soil amendment. In this process, wastewater solids are anaerobically digested and stored in facultative sludge lagoons. During the summer months, the stabilized biosolids are dredged from the lagoons and land applied at an agronomic rate as a soil conditioner.

This process would only work if PCSD could find an available area to use the solids; otherwise, the necessary footprint would increase drastically in order to have enough area to spread the solids. The ponds themselves also cause some concerns. The first concern is that the footprint for the ponds will be larger than the other alternatives. Secondly, there are community concerns with the visual aesthetics of a large exposed water surface like a sludge lagoon. Finally, treatment options that provide anaerobic conditions commonly produce more odors than aerobic conditions. This could cause issues with surrounding neighbors. There would be higher capital and operational costs associated with this alternative, and a large footprint would be required with potential aesthetic concerns. Because of the offensive odors



that can be generated from facultative sludge lagoons, as well as the required footprint, Alternative #3 was eliminated from consideration.

- The final, and cost prohibitive option that we briefly considered would be construction of a thermal treatment system similar to what was recently installed in Rio Dell. However, this system is significantly more expensive and more complicated than the above alternatives and still (ultimately) requires a site to dispose of the treated biosolids. For these reasons, this alternative was eliminated from additional consideration.

6.4.3 Solids Handling Design Criteria

As discussed in Section 5, the base sanitary flow for the PCSD is 60,000 gpd. With full build-out of the peninsula, in 30 or more years, the base sanitary flow could be 200,000 gpd. A peaking factor of 4.0 was used to arrive at a design peak hour flow (highest hourly flow during the wet season) of 240,000 gpd, increasing to 760,000 gpd with full peninsula build-out.

Independent Pumping Service

For independent pumping the biosolids would likely need to be pumped on a regular basis. For the purposes of this analysis we have assumed that this would occur once a month. Pumping would entail removing some of the scum layer at the top and much of the settled solids at the bottom of the holding tank, likely requiring two or three 2,500-gallon trucks every other time the holding tank was pumped.

On-site Dewatering

The following infrastructure would be required to integrate a dewatering system:

- Polymer injection system and mixing tank
- Sludge dewatering container
- Covered concrete holding area for dried solids
- Sludge pumps

A dewatering sludge container in the form of a trailer or self-dumping unit would be most economical. A concrete holding area would likely also be required to store the cake until there is enough to haul. A front end loader or backhoe would be required to load the cake into a trailer to be hauled.

Important design considerations for this alternative are connected to how often the holding tank would need to be pumped, how much material would need to be pumped, and how much material would need to be hauled away and disposed of at a landfill. The following assumptions were made in determining these design elements:

- Average daily flow is 60,000 gpd.
- Influent TSS concentration is 195 mg/L.
- Of the incoming TSS, 70% will settle out in the tank.
- Over time, there will be 50% solids decomposition in the tank.



- The sludge pumped out of the tank will contain 2% solids.
- Sludge will be dewatered to 15%-20% solids in a roll-off style container.
- The treated solids would be stored on a concrete pad with a removable cover that would allow additional drying to occur. Further, the pad would allow the District to accumulate enough solids to fill a truck prior to disposal.
- Our analysis assumes that the only solids that would be handled by this system are those that are generated by the District's wastewater treatment system. However, the District could use this system to also treat septage from the surrounding community.

The above assumptions were used to determine costs for on-site dewatering.

6.4.4 Solids Handling Potential Environmental Impacts

A full analysis of potential environmental impacts will be included in the EIR that will be completed prior to completion of the planning phase for this project. The potential impacts for solids management are similar to wastewater treatment, particularly the potential to generate odors. Ensuring that on-site solids handling does not generate odors requires a good design and good operation and maintenance. Similarly, proper design can mitigate noise impacts from pumps and blowers.

6.4.5 Solids Handling Land and Permitting Requirements

There would be no additional land requirements if a local pumping service was used.

An on-site dewatering system would require enough area for a polymer system, sludge dewatering container, and concrete holding area for dried solids. We estimate that this would require about 0.5 acres.

6.4.6 Solids Handling Opinion of Probable Cost

An opinion of probable construction cost was developed for an on-site dewatering system (Table 6-15). The system is capable of producing and storing 15% solids until transport to the Anderson Landfill. There is no capital cost involved with having an independent contractor pump and haul the solids away.



Table 6-15: Opinion of probable construction cost for an on-site dewatering system.

| Item | Quantity | Unit | Unit Cost | Total Cost |
|------------------------------|----------|------|-----------|------------------|
| Roll-off Dewatering Tank | 1 | LS | \$40,000 | \$40,000 |
| Polymer System | 1 | LS | \$20,000 | \$20,000 |
| Site Work | 1 | LS | \$30,000 | \$30,000 |
| Miscellaneous Piping | 1 | LS | \$18,000 | \$20,000 |
| Electrical | 1 | LS | \$18,000 | \$20,000 |
| Concrete Holding Area | 1 | LS | \$12,000 | \$10,000 |
| Sludge Pump | 2 | LS | \$500 | \$1,000 |
| Construction Subtotal | | | | \$140,000 |
| Permitting (5%) | | | | \$10,000 |
| Engineering Design (20%) | | | | \$30,000 |
| Geotechnical (5%) | | | | \$10,000 |
| Contingency (20%) | | | | \$30,000 |
| Total | | | | \$220,000 |

Table 6-16 presents the 20-year present worth costs for both solid handling alternatives. Despite the lack of capital cost and having less operation and maintenance labor the cost of paying to have the solids taken away is slightly more than building and operating an on-site dewatering system.

Table 6-16: 30-year Present Worth Costs for the Solids Handling Systems.

| Description | Independent Pump & Haul | On-site Dewatering |
|------------------------------------|-------------------------|--------------------|
| Capital Cost | \$0 | \$220,000 |
| Annual O&M Cost | \$28,000 | \$6,000 |
| 30-yr O&M Present Worth | \$650,000 | \$140,000 |
| 30-yr Total Present Worth | \$650,000 | \$360,000 |

6.4.7 Comparison of Solids Handling Alternatives

The advantage of contracting a local pumping service to dispose of the sludge is that there would be no additional capital cost required to construct facilities to handle the solids. No additional operational costs would be required beyond scheduling and paying the septic hauler to pump and dispose of the waste. A disadvantage of this alternative is that the septic hauler would pump liquid along with the solids, and the District would need to pay for the hauling and disposal of this excess liquid along with the solids. Onsite dewatering is the recommended solids handling alternative due to the cost saving potential.



7. Apparent Best Project

The apparent best project, shown in Figure 7-1, includes the following elements:

- Collection system: Pressure sewer collection system with individual grinder pumps at each connection
- Treatment system: Secondary treatment with an SBR system followed by UV disinfection at the proposed Town of Samoa WWTP location
- Disposal: Use of the ocean outfall pipe at the RMT-II site
- Solids treatment: On-site dewatering using a polymer injection system and a roll-off style dewatering container

The apparent best project uses a pressurized collection system, including individual grinder pumps at each connection and a primary pressure main running south to north along Vance Avenue, to pump raw wastewater to a centralized WWTP. The collected influent would enter a wastewater treatment plant at the proposed Town of Samoa location, going through primary treatment of bar screening and grit removal. Then the wastewater would be treated in an SBR basin and the treated effluent would pass UV disinfection lamps. After disinfection, the effluent would be pumped to Manhole 5 for disposal through the ocean outfall pipe at RMT-II. Solids removed from the SBR would be dewatered on site using a polymer injection system with a roll-off style container and then stored on site until hauled to the Anderson Landfill.

It should be noted that if the zoning at the RMT-II site is successfully changed from Coast Dependent Industrial to General Industrial, the preferred WWTP site would actually be the RMT-II site. This alternative location should be analyzed in the EIR and if zoning is changed prior to design and construction of this project, consideration should be seriously given to placing the WWTP site to RMT-II.

7.1 Preliminary Project Design

7.1.1 Collection System

The proposed collection system consists of gravity flow pipes in the communities of Fairhaven and Finntown, connected by a single pressure pipe running north to a centralized WWTP near the Town of Samoa. Gravity pipe will be a minimum diameter of 8 inches to allow for easy access of cleaning and inspection equipment. Manholes will be placed a maximum of every 500 feet, at each change in vertical or horizontal alignment, within existing right of ways and streets, and at the end of every pipe run. Gravity mains and laterals will be constructed to prevent floatation during seismic events or due to high groundwater.

Each community will have at least one centralized pump station to pump raw wastewater to the WWTP through the central pressure main. The pressure main will include air relief valves at each rise in the pipe with air scrubbers to remove noxious gasses and odors. The pressure main will also include cleanout stations at each change in horizontal or vertical alignment, and at the end of every pipe run, for launching of a PIG to clean the pipe when necessary.



7.1.2 Treatment System and Treated Water Disposal

The wastewater in the system would be conveyed to the proposed Town of Samoa WWTP location. At this location, the raw wastewater would have primary treatment of screening and grit removal followed by secondary treatment with an SBR system. Lastly the effluent from this system would be disinfected by a UV system and then transported to Manhole 5 for ocean disposal through the outfall.

7.1.2.1 Sequencing Batch Reactor

SBRs consist of a modification to the activated sludge process, which is the standard process used to achieve secondary treatment. While conventional activated sludge facilities typically rely on multiple basins, SBR systems combine all of the treatment steps and processes into one basin. This is accomplished by controlling the level of liquid and providing aeration. SBR operation is based on a five-step cycle:

1. **Fill:** the basin is filled with influent wastewater. The influent creates an environment for biochemical reactions by bringing consumables to the microbes in the activated sludge. Mixing and aeration can occur during the filling process.
2. **React:** no wastewater enters the basin during this step, and mechanical mixing and aeration units are activated. Carbonaceous BOD and phosphorus are taken up during this phase by the microbes.
3. **Settle:** aeration and mixing cease, and activated sludge is allowed to settle.
4. **Decant:** after settling is complete, the clear supernatant effluent is decanted.
5. **Idle:** after decanting and before the next filling phase, a small amount of activated sludge is pumped out of the bottom of the basin.

Primary treatment in the form of screening and grit removal must occur before the five-step process mentioned above. The SBR process can be modified to achieve the required nitrogen removal with the addition of an initial anoxic basin where denitrification can take place.

A Level III licensed operator would be required to operate and maintain an SBR system below 1 million gallons per day. The operator must have adequate knowledge about SBR systems to correct any problems with the facility, if they occur.

The EcoCycle SBR system is designed with two basins that are sized to treat both existing and future flows. They have the capacity to handle the projected future peak flow of 758,000 gpd. The components were the same with only a minimal change in basin size between the two design flows, therefore it is recommended to install a system sized for the larger, future flows. While flows are lower in the beginning the system can be run at a lower water level. Each basin has a flow control manifold, floating decanter, fixed bubble diffusers, blowers and accessories, waste sludge pump, influent and effluent valves, and a process control panel with dynamic controls that respond to the influent flow rates. A complete cycle of the five steps will take six hours, allowing for four batches per basin in a day, and providing approximately 21 hours of hydraulic retention time. The effluent wastewater will be treated to 30 mg/L for both BOD and TSS. For more SBR details, sizing, and parameters see Appendix G. Each basin is 36 feet by 18 feet with a top water level of 18 feet.

Data Disclaimer:
 Town of Samoa wastewater collection system layout from California Engineering Company, 2017. Samoa Treatment Plant Rehabilitation Project. Design Plans.

Legend

- (P) Pump Stations
 - STMP
 - Other
- ← (P) Pressure Main
- (P) Gravity Main (STMP)
- - - (E) Ocean Outfall
- (P) WWTP Site
- Samoa Town Master Plan Area
- ▭ (P) Peninsula CSD Boundary

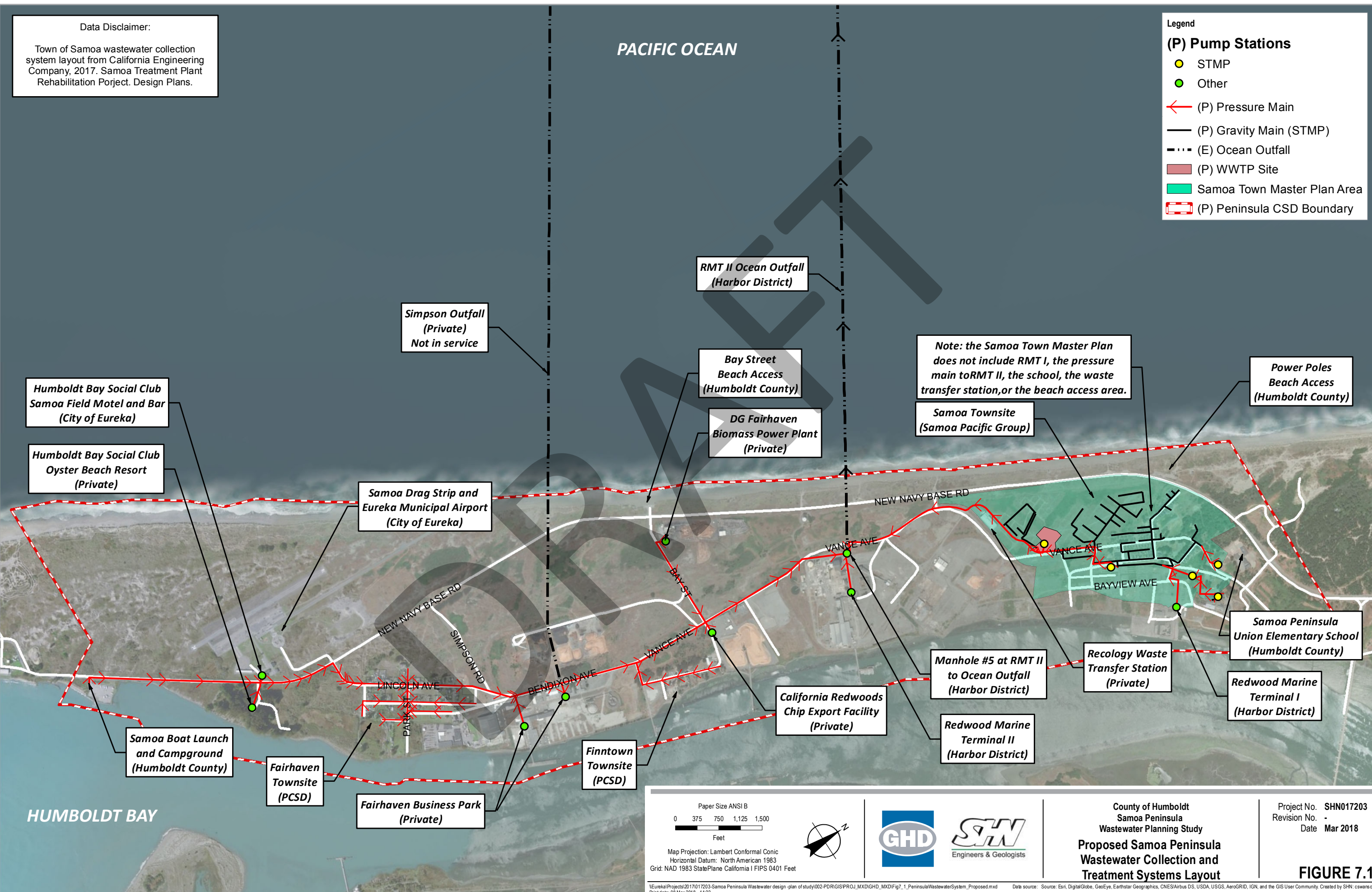

Paper Size ANSI B
 0 375 750 1,125 1,500
 Feet

Map Projection: Lambert Conformal Conic
 Horizontal Datum: North American 1983
 Grid: NAD 1983 StatePlane California I FIPS 0401 Feet



County of Humboldt
 Samoa Peninsula
 Wastewater Planning Study
**Proposed Samoa Peninsula
 Wastewater Collection and
 Treatment Systems Layout**

Project No. SHN017203
 Revision No. -
 Date Mar 2018

FIGURE 7.1

\\Eureka\Projects\20170117203-Samoa Peninsula Wastewater design-plan of study\002-PDR\GIS\PROJ_MXD\GHD_MXD\Fig7_1_PeninsulaWastewaterSystem_Proposed.mxd Date source: Source: Esri, DigitalGlobe, GeoEye, Earthstar Geographics, CNES/Airbus DS, USDA, USGS, AeroGRID, IGN, and the GIS User Community. Created by SHN: cswanson Print date: 08 Mar 2018 - 14:22

DRAFT



Accounting for the treatment system itself, as well as area for a control building, office space, lab space, and additional components, such as, vacuum trucks, etc., the total required footprint area for this system would be approximately 35,000 square feet (slightly over an acre).

7.1.2.2 UV Disinfection

After secondary treatment, the wastewater will pass by the UV disinfection system as it exits the plant for disposal. As a physical process, the UV light “touching” the pathogens is what accomplishes the disinfection. It is important to have proper mixing to ensure all pathogens have been touched by the light.

There are minimal operator needs beyond lamp replacement every one to two years. The Trojan UV Fit system chosen has automated lamp wipers, reducing maintenance needs.

For the existing flows, one 18-lamp Trojan system should be installed with the ability to add an additional 18-lamp system to handle full build out flows. The Trojan system can handle full decanting flow rates from the SBR system, meaning no equalization basin is needed between the two. The lamps are high-efficiency, high-output, low-pressure Amalgam that maintain 98% output over the entire lamp life while requiring less energy than traditional lamps. The system also comes with UV transmittance sensors to ensure proper dose delivery and a user friendly operator interface. The Trojan UVFit system is nearly 7 feet long and a diameter of less than 2 feet, the 18 lamps fit into one sleeve with the water flowing parallel. All parts can be serviced from the front cap, which should have more than 4 feet of open space in front to allow easy access. For more UV details, sizing, and parameters see Appendix H.

7.1.2.3 Ocean Disposal

The proposed ocean discharge location is through the ocean outfall located at RMT-II. A pressurized effluent pipeline with one pump station will be constructed from the wastewater treatment plant to Manhole 5 for connection to the ocean outfall. The effluent pipeline will be installed beneath existing roadways to minimize environmental impacts. To easily handle all future flows a 6-inch PVC pipeline should be installed. If the treatment plant is installed at the proposed Town of Samoa location, the effluent pipeline will be approximately 4,000 feet long.

7.1.3 Solids Dewatering and Disposal

The apparent best solids handling alternative is to dewater the solids using a batch process on site and then haul the dried solids, or “cake,” to either a landfill or composting operation. Currently, the landfill in Anderson, California is the nearest landfill that will accept these solids. There are also composting facilities in the Humboldt Bay area that could potentially accept these solids. (Note: a WDR permit is required in order to accept Class B biosolids)The available options can and likely will change with time. Therefore, we recommend the District hold off on further exploration of these options until it is in the final design phase of the project. At that time, it may be advantageous for the District to enter into an agreement for use of these solids.

The following infrastructure would be required to integrate a dewatering system:

- Polymer injection system and mixing tank
- Sludge dewatering container



- Covered concrete holding area for dried solids
- Sludge pumps

Important design considerations for this alternative are connected to how often the tank would need to be pumped, how much material would need to be pumped, and how much material would need to be hauled away and disposed of at a landfill. The following assumptions were made in determining these design elements:

- SBR dry solids wasting is 353 pounds per day.
- Solids concentration in waste activated sludge is 0.85%.
- Total volume wasted per day is 4,976 gallons per day.
- Sludge will be dewatered to 15%-20% solids in a roll-off style container.
- The treated solids would be stored on a concrete pad with a removable cover that would allow additional drying to occur. Further, the pad would allow the District to accumulate enough solids to fill a truck prior to disposal.
- Our analysis assumes that the only solids that would be handled by this system are those that are generated by the District's wastewater treatment system. However, the District could use this system to also treat septage from the surrounding community.

The above assumptions were used to determine costs for this alternative.

The operational costs for this process will include the operator wages (the treatment plant operator would be able to operate the dewatering equipment as well), a contracted truck/driver to haul the cake to the landfill or composting facility, disposal costs associated with either the landfill or the composting facility, polymer to mix with the sludge, testing of the sludge and energy costs to run the polymer system, as well as any pumps and vehicles needed.

7.2 Total Project Opinion of Probable Cost

We have developed an opinion of the probable costs for the total project. This opinion covers both the costs for the actual construction, as well as the "soft" costs for engineering, permitting, legal, administration, and land acquisition. In addition, we have included a 20% contingency to reflect the uncertainties with the project at this stage.

7.2.1 Collection System

Table 7-1 includes the opinion of probable cost for a complete gravity sewer system for the PCSD service area. As mentioned previously, the subtotal for length of pipe south of Fairhaven has been broken out separately. The construction subtotal for this segment of pressure main is \$940,000 (including 12% for mobilization).



Table 7-1: Opinion of probable project cost for gravity sewer system.

| Item Description | Quantity | Units | Unit Cost | Total Cost |
|--|----------|-------|-----------|--------------------|
| Pump Station - Fairhaven | 1 | EA | \$130,000 | \$130,000 |
| Pump Station - Finntown | 1 | EA | \$100,000 | \$100,000 |
| Laterals, Main to Right-of-Way | 76 | EA | \$2,000 | \$150,000 |
| Gravity Main – Deep Trench | 4,740 | LF | \$110 | \$520,000 |
| Gravity Main – Shallow Trench | 2,860 | LF | \$90 | \$260,000 |
| Pressure Main – South of Fairhaven | 5,000 | LF | \$80 | \$400,000 |
| Pressure Main – All Else | 10,600 | LF | \$80 | \$850,000 |
| Gravity Main Trench Dewatering | 7,600 | LF | \$65 | \$490,000 |
| Pressure Main Trench Dewatering – South of Fairhaven | 5,000 | LF | \$30 | \$150,000 |
| Pressure Main Trench Dewatering – All Else | 10,600 | LF | \$30 | \$320,000 |
| Gravity Main Surface Restoration | 60,800 | SF | \$12 | \$730,000 |
| Pressure Main Surface Restoration – South of Fairhaven | 20,000 | SF | \$12 | \$240,000 |
| Pressure Main Surface Restoration – All Else | 42,400 | SF | \$12 | \$510,000 |
| Pressure Main Cleanouts – South of Fairhaven | 4 | EA | \$10,000 | \$40,000 |
| Pressure Main Cleanouts – All Else | 26 | EA | \$10,000 | \$260,000 |
| Valves – South of Fairhaven | 4 | EA | \$2,500 | \$10,000 |
| Valves – All Else | 6 | EA | \$2,500 | \$20,000 |
| Mobilization (12%) | 1 | LS | \$620,000 | \$620,000 |
| Construction Subtotal | | | | \$5,800,000 |
| Permitting (5%) | | | | \$290,000 |
| Engineering Design and Construction Phase Services (20%) | | | | \$1,160,000 |
| Geotechnical (5%) | | | | \$290,000 |
| Contingency (20%) | | | | \$1,160,000 |
| Legal, Administration (5%) | | | | \$290,000 |
| Total Project | | | | \$8,990,000 |

Annual O&M costs for the proposed gravity sewer system include annual cleaning of the two proposed pump stations in Fairhaven and Finntown, regular camera inspection of gravity pipes, regular jet cleaning of gravity pipes, and power to run the pump stations (Table 7-2). Camera inspection and jet cleaning are assumed to take place simultaneously because jetting is often required prior to camera inspection. Initially, cleaning and inspection of the new sewer system may not be necessary, but over the lifetime of the system it is assumed that 10% of the piping will be cleaned and inspected annually (760 feet per year). Note that the cost of jet cleaning gravity sewer pipes will vary depending on the amount of material present in the pipes.

O&M costs for pigging the central pressure main are not included in this project cost estimate because cleaning of the pressure sewer may not ever be required. Water velocity in the pipes



should prevent accumulation of material; however, if the system is sized for the full project buildout and buildout never occurs for some reason, design velocities may not be obtained, and material may accumulate in the pipes. If this occurs, pressures will increase, and cleaning will be required.

Table 7-2: Opinion of probable annual operation and maintenance cost for gravity sewer system.

| Item Description | Quantity | Units | Unit Cost | Total Cost |
|--------------------------------|----------|-------|-----------|----------------|
| Pump Station Cleaning | 2 | EA | \$700 | \$1,400 |
| Gravity Main Jet Cleaning | 760 | LF | \$2 | \$1,500 |
| Gravity Main Camera Inspection | 760 | LF | \$1 | \$800 |
| Pump Station Power Cost | 12 | LS | \$450 | \$5,400 |
| Total Annual O&M | | | | \$9,000 |

7.2.2 Wastewater Treatment System

Our opinion of the probable cost for construction of the SBR treatment system include considerations for site work, primary treatment using bar screening and grit removal, all necessary yard piping, required components for the installation of the SBR basins and UV system, a control building, and other miscellaneous items, as shown in Table 7-3

Table 7-3: Opinion of probable cost for the wastewater treatment system including primary, secondary, and disinfection treatment.

| Item | Quantity | Unit | Unit Cost | Total Cost |
|--|----------|------|-----------|--------------------|
| Site Work | 1 | LS | \$100,000 | \$100,000 |
| Bar Screen | 1 | LS | \$300,000 | \$300,000 |
| Grit Removal | 1 | LS | \$200,000 | \$200,000 |
| SBR (FOB Samoa) | 1 | LS | \$300,000 | \$300,000 |
| SBR (installation, including pad) | 1 | LS | \$250,000 | \$250,000 |
| Trojan UV System (FOB Samoa) | 1 | LS | \$70,000 | \$70,000 |
| Concrete | 30 | CY | \$700 | \$20,000 |
| Yard Piping and valves | 1 | LS | \$60,000 | \$60,000 |
| Control Building | 1 | LS | \$300,000 | \$300,000 |
| Electrical | 1 | LS | \$230,000 | \$230,000 |
| Construction Subtotal | | | | \$1,830,000 |
| Permitting (5%) | | | | \$80,000 |
| Legal, Administration | | | | \$100,000 |
| Engineering Design and construction phase services (20%) | | | | \$340,000 |
| Geotechnical (5%) | | | | \$80,000 |
| Contingency (20%) | | | | \$340,000 |
| Total | | | | \$2,770,000 |



Annual O&M for the treatment system includes a full time operator, the electricity to power the system based on power consumption provided by Parkson Corporation, and an estimated annual maintenance of 2% the total capital cost presented in Table 7-4.

Table 7-4: Opinion of probable operation and maintenance cost for the treatment system.

| Item Description | Quantity | Units | Unit Cost | Total Cost |
|-----------------------------|----------|-------|-----------|------------------|
| Labor | 2,080 | HR | \$40 | \$83,000 |
| Electricity | 96,000 | kWh | \$0.13 | \$12,000 |
| Annual Maintenance | 1 | LS | \$60,000 | \$60,000 |
| Total Annual O&M | | | | \$155,000 |

7.2.3 Wastewater Disposal

Our opinion of the probable costs for construction of the pipeline to the ocean outfall Manhole 5 include considerations for the trench excavation and disposal of native material, installation of 6-inch PVC piping, an effluent pump station, miscellaneous valves, and finishing paving and is presented in Table 7-5. The O&M for the system is estimated at \$10,000 annually to cover the cost of pumping the effluent from the treatment plant to Manhole 5.

Table 7-5: Opinion of probable cost for the disposal pipeline to the ocean outfall.

| Item | Quantity | Unit | Unit Cost | Total Cost |
|--|----------|------|-----------|------------------|
| 6-inch PVC Pipe | 4,000 | LF | \$100 | \$400,000 |
| Paving | 4,000 | LF | \$20 | \$80,000 |
| Effluent Pump Station | 1 | EA | \$120,000 | \$120,000 |
| Misc. Valving | 1 | LS | \$10,000 | \$10,000 |
| Construction Subtotal | | | | \$610,000 |
| Permitting (5%) | | | | \$30,000 |
| Engineering Design and construction phase services (20%) | | | | \$120,000 |
| Geotechnical (5%) | | | | \$30,000 |
| Contingency (20%) | | | | \$120,000 |
| Total | | | | \$910,000 |

7.2.4 Solids Handling and Disposal

Our opinion of the probable capital cost associated with the proposed solids handling system includes:

- Polymer injection system and mixing tank
- Sludge dewatering container
- Covered concrete holding area for dried solids
- Sludge pumps



This opinion is presented in Table 7-5.

Table 7-5: Opinion of probable cost for the solids handling system.

| Item | Quantity | Unit | Unit Cost | Total Cost |
|------------------------------|----------|------|-----------|------------------|
| Roll-off Dewatering Tank | 1 | LS | \$40,000 | \$40,000 |
| Polymer System | 1 | LS | \$20,000 | \$20,000 |
| Site Work | 1 | LS | \$30,000 | \$30,000 |
| Miscellaneous Piping | 1 | LS | \$18,000 | \$20,000 |
| Electrical | 1 | LS | \$18,000 | \$20,000 |
| Concrete Holding Area | 1 | LS | \$12,000 | \$10,000 |
| Sludge Pump | 2 | LS | \$500 | \$1,000 |
| Construction Subtotal | | | | \$140,000 |
| Permitting (5%) | | | | \$10,000 |
| Engineering Design (20%) | | | | \$30,000 |
| Geotechnical (5%) | | | | \$10,000 |
| Contingency (20%) | | | | \$30,000 |
| Total | | | | \$220,000 |

The O&M costs for the solids handling includes hauling and disposing of solids at the Anderson Landfill, polymer costs, and an estimated annual maintenance of 2% the total capital cost presented in Table 7-6.

Table 7-6: Opinion of probable operation and maintenance cost for the solids handling system.

| Item Description | Quantity | Units | Unit Cost | Total Cost |
|-----------------------------|----------|-------|-----------|-----------------|
| Haul to Landfill | 20 | TRIPS | \$1,000 | \$20,000 |
| Disposal at Landfill | 215 | TON | \$55 | \$10,000 |
| Annual Maintenance | 1 | LS | \$4,000 | \$4,000 |
| Polymer Costs | 1 | LS | \$5,000 | \$5,000 |
| Total Annual O&M | | | | \$40,000 |

7.2.5 Total Project Opinion of Probable Cost

Our opinion of the total capital cost for the project includes cost for constructing all of the elements described above for the collection, treatment, and disposal facilities and is presented in Table 7-7. The detailed capital costs breakdowns can be found in the previous subsections of 7.2.



Table 7-7: Opinion of probable capital and O&M for the total project.

| Item | Capital Cost | Annual O&M |
|--|---------------------|------------------|
| Collection System | \$5,800,000 | \$9,000 |
| Treatment - SBR and UV | \$1,830,000 | \$155,000 |
| Disposal - Ocean Outfall Line | \$610,000 | \$10,000 |
| Solids - Dewatering System | \$140,000 | \$40,000 |
| Construction Subtotal | \$8,380,000 | - |
| Permitting (5%) | \$420,000 | - |
| Legal, Administration (5%) | \$420,000 | - |
| Engineering Design and Construction Phases (20%) | \$1,680,000 | - |
| Geotechnical (5%) | \$420,000 | - |
| Contingency (20%) | \$1,680,000 | - |
| Total | \$13,000,000 | \$214,000 |

7.3 Permitting for Proposed Project

Because all collection system and disposal piping is proposed to be installed beneath existing roadways, it is assumed that no easements or right-of-way will need to be obtained from landowners.

- The LCP needs to be updated to allow for community wastewater service to the communities of Fairhaven and Finntown
- The project appears to be located entirely within the “Appeal” portion of the Coastal Zone. Therefore the project would require a coastal development permit (CDP) from the County of Humboldt which would be appealable to the California Coastal Commission (CCC). Alternatively, if the project includes areas within the CDP jurisdiction of both the County and the State (CCC), then the CDP process would be consolidated to the CCC, resulting in a single CDP.
- The CDP for the Samoa townsite needs to be updated to allow for acceptance of the proposed WWTP site for wastewater from outside Samoa. Alternatively, the zoning of the RMT-II site needs to be changed to General Industrial to allow for construction of a municipal WWTP at that site.
- A Report of Waste Discharge (Form 200) must be filed with the NCRWQCB and a Waste Discharge Permit be obtained for the proposed WWTP and for discharge through the ocean outfall. Discharge through the outfall will also require an NPDES permit (see Section 7.4).
- Encroachment permit(s) will be required from Humboldt County Department of Public Works, Land Use Division for work within County rights-of-way.
- The project may also require a conditional use permit from the County. However, if the project is seen as exclusively a municipal/public project, this permit may not be required.



- An ACOE Clean Water Act Section 404/Section 10 permit would be required if the project were to involve filling of or work in Waters of the U.S.
- An RWQCB Clean Water Act Section 401 water quality certification would be required if an ACOE permit were required or if the project were to involve filling of or work in Waters of the State, which it likely will.
- The project will require coverage under the SWRCB construction general permit (including preparation of a stormwater pollution prevention plan) if it involves one acre or more of ground disturbance.
- CDFW requires a Lake and Streambed Alteration (LSA) Agreement when it determines that the activity, as described in a complete LSA Notification, may substantially adversely affect existing fish or wildlife resources. LSA Notification would be required if any project element involves work in a CDFW-jurisdictional watercourse or ditch (or its associated riparian vegetation).
- The California State Lands Commission's (CSLC) jurisdiction includes the State's tide and submerged lands that extend from the shoreline out to three miles offshore. A CSLC lease is in place with the HBHRCD for the ocean outfall lease.

Other than initial discussions between the County of Humboldt and the CCC, permitting agencies have not yet been contacted about this project. The CDP process will be consolidated to the State (CCC). Other permits will be applied for based on the Apparent Best Project.

7.4 Waste Discharge Requirements

Waste discharge requirements (WDRs) for the proposed municipal wastewater collection, conveyance, and treatment facilities to be owned and operated by the PCSD will be regulated by the NCRWQCB. The NCRWQCB will issue a waste discharge permit for discharge of treated effluent based on the receiving water for the discharge. Discharge to the Pacific Ocean through the ocean outfall at RMT-II is considered a discharge to surface water and will be regulated in accordance with the 2015 California Ocean Plan (SWRCB, 2015). Discharges to surface waters require a national pollutant discharge elimination system (NPDES) permit issued by the NCRWQCB.

The NCRWQCB has indicated that multiple types of waste discharged to the ocean outfall at RMT-II will require multiple, individual permits for each waste discharger. Currently, the DG Fairhaven biomass power plant holds the only NPDES permit for discharge of industrial process water to the ocean outfall. The HBHRCD is also in the process of applying for an NPDES permit for treated aquaculture wastewater that would potentially discharge to the ocean outfall. SPG has also submitted an NPDES permit application for the proposed WWTP for the STMP to discharge treated municipal wastewater to the ocean outfall.

The SPG NPDES permit application for discharge to the ocean outfall is under review by the NCRWQCB. If issued, this permit would allow the STMP to proceed with its development project in the Town of Samoa. In order to combine the proposed PCSD service area with the STMP service



area into a single treatment system and discharge permit, PCSD and SPG will need to develop a plan for transfer of wastewater assets, operation, and management.

Recent WDRs issued by the NCRWQCB for ocean discharger include new requirements to conduct biological surveys and physical inspections of the ocean outfall structures, and develop climate change readiness plans for all wastewater facilities. Studies involving the ocean outfall may be conducted in a joint effort by all parties discharging to the ocean outfall including DG Fairhaven, the HBHRCD, and SPG or PCSD. The cost of these studies is unknown at this time and may vary with the number of outfall users, and the type and location of collection, conveyance, and treatment facilities.

7.5 Key Issues for the Proposed Project

7.5.1 Collection System

- Trenching in sand during construction may require extensive and costly shoring
- Shallow groundwater may require costly groundwater extraction during construction and may contribute to higher inflow and infiltration as system ages
- Impacts to Environmentally Sensitive Habitat Areas (ESHAs) will be limited by placing system in roadways as much as possible, but existing ESHAs will need to be mapped as part of the EIR process and may change the design slightly.
- Traffic impacts during construction will require mitigation
- Dewatering and disposal of water during construction will require permitting for disposal
- Final design will need to confirm existing right-of-ways and easements for placement of collection system pipes

7.5.2 Treatment System

- The existing Samoa Townsite Coastal Development Permit and EIR will need to be updated to allow for the wastewater treatment plant site to accept flows from outside the Samoa Townsite
- The existing Samoa Townsite landowner (Samoa Pacific Group) would prefer consolidated treatment plant be located at the Harbor District's RMT-II facility to free up land in Samoa and not require an extensive coordination between a treatment facility capable of treating existing Samoa Townsite flows and future flows from the rest of the PCSD. The Humboldt Bay Harbor Recreation and Conservation District is amenable to this idea, but the RMT-II site zoning will not currently allow for the construction of a wastewater treatment site treating offsite flows to be constructed on this site (see Permitting section below)
- May require land acquisition or easements depending on final placement of the treatment plan
- Discharge requirements unknown at this time, but should not be an issue assuming typical secondary treatment levels are required by the SWRCB



- Lack of local experienced and properly licensed Wastewater Treatment Operators (Grade III Operator) is always a challenge in rural areas of California
- Will need to negotiate an outfall agreement with reasonable discharge rates with HBHRCD

7.5.3 Permitting

- Humboldt Bay Area Plan will need to be updated to allow for the construction of a wastewater collection and treatment plant for the Fairhaven, Finntown and other areas of the PCSD outside the Samoa Townsite
- Coastal dependent industrial zoning limits the location where a treatment plant can be constructed including on the majority of the HBHRCD RMT-II site. This zoning will need to be changed to allow for the construction of the wastewater treatment plant at this site
- A Coastal Commission Coastal Development Permit will be required and will likely require extensive negotiation with the California Coastal Commission, which may change the final design
- There are extensive ESHAs on the Samoa Peninsula, which likely cannot be impacted
- The construction of the collection system and treatment plant will likely require obtaining easements and may require the purchase of some land
- All of the above issues and others need to be addressed in the EIR

7.5.4 Other

- The PCSD takeover of SPG wastewater assets will need to be closely coordinated and agreed upon

7.5.5 Funding

- The final approval of a formal wastewater system rate will need to be conducted as part of a formal Proposition 218 process
- Reasonable wastewater rates will require 100% grant funding of the project, and this amount of grant funds may not be available
- Grant funding will likely require multiple funding sources, which will require multiple application packages and will complicate the eventual construction and grant coordination
- Upon their formation, the PCSD will be a new CSD with very limited funding resources or reserves

7.6 Preliminary Operating Budget and Rate Schedule

A wastewater user fee is designed to provide a source of revenue for operation, maintenance, and replacement costs of the wastewater system that meets jurisdictional goals and policies along with satisfying federal and state requirements. In addition, debt service and revenue for establishing a capital reserve fund and an operating reserve fund should be collected by District. All sewer service



charges imposed in California must also comply with the provision of Article XIID of the California Constitution (Proposition 218). Section 6(b) of Proposition 218 requires the local agency to meet all of the following requirements for all “new, extended, imposed or increased” fee and charges:

- “Revenues derived from the fee or charge shall not exceed the funds required to provide the property related service.”
- “Revenues derived from the fee or charge shall not be used for any purpose other than that for which the fee or charge was imposed.”
- “The amount of a fee or charge imposed upon any parcel or person as an incident of property ownership shall not exceed the proportional cost of the service attributable to the parcel.”
- “No fee or charge may be imposed for a service unless that service is actually used by, or immediately available to, the owner of the affected property. Fees or charges based on potential or future use of a service are not permitted. Standby charges, whether characterized as charges or assessments, shall be classified as assessments and shall not be imposed without compliance with Section 4 [of Proposition 218].”
- “No fee or charge may be imposed for general governmental services including, but not limited to, police, fire, ambulance or library services, where the service is available to the public at large in substantially the same manner as it is to property owners.”

To impose a sewer charge or an increased sewer charge, the District is required to:

- Mail information regarding the proposed fee to every property owner
- Conduct a public hearing at least 45 days after the mailing
- Reject the proposed fee if written protests are presented by a majority of the affected property owners

Several objectives were considered in the design of service rates. The major objectives considered in this section are as follows:

- Financial Sufficiency
- Customer Equity
- Revenue Stability
- Minimize Customer Impacts
- Simple to Understand and Update
- Ease of Implementation
- Rate Stability

7.6.1 Operation, Maintenance, and Replacement Costs

Operations and Maintenance (O&M)



Operation and maintenance expenses are incurred by the District to provide sewer service to its customers. These expenses are accounted for during the current year and are not capitalized or amortized over an extended period of years. O&M costs include salaries and benefits, professional services, utilities, materials and supplies, and other items necessary to operate and maintain the District's sewer collection and treatment systems. Typically, when evaluating and setting rates for an agency, annual operating expenses have been well defined through years of operations along with reserve and capital improvement program requirements. However, as a "start-up" district, the PCSD has no history of expenses from which to draw as related to a wastewater program. O&M costs presented in the budget are reflective of costs presented in the project alternative analyses.

Replacement

Replacement costs include all expenditures required for a facility to operate for its design life. Replacement costs do not include costs associated with major, structural rehabilitations; or facility expansions or upgrades to meet future user demands or upgrade treatment. Replacement costs do include such items as pumps, motors, telemetry and electrical controls, air, disinfection equipment, vehicles, radios, etc. Items associated with replacement costs are often termed "Short Lived Assets." Table 7-8 lists the District's short lived assets along with projected installation costs and life expectancy.

Replacement costs should be based, at a minimum, on either: a five-year capital improvement planning (CIP) cycle or a replacement fund equal to the sum of the straight line depreciation (based on current costs) of the assets (excluding structural facilities, such as, buildings, ponds, pipes, etc). The District will have an all new collection and treatment system, therefore a CIP has not been developed. Instead, the latter method is used for establishing a replacement cost to be placed in a reserve fund as expenditures for a new system are not anticipated in the short term.



Table 7-8: Short Lived Assets

| Item | Asset | Replacement Unit Cost | No. | Units | Useful Life (yrs) | Total Replacement Cost | Annual Depreciation |
|---------------------------------------|--|-----------------------|-----|-------|-------------------|------------------------|---------------------|
| 1 | Pumps to Outfall | \$10,000 | 3 | EA | 10 | \$30,000 | \$3,000 |
| 2 | Controls for Pumps to Outfall | \$5,000 | 1 | EA | 10 | \$5,000 | \$500 |
| 3 | SCADA Equipment | \$25,000 | 1 | LS | 15 | \$25,000 | \$1,667 |
| 4 | Small Generator | \$20,000 | 1 | EA | 15 | \$20,000 | \$1,333 |
| 5 | Large Generator | \$100,000 | 1 | EA | 15 | \$100,000 | \$6,667 |
| 6 | Grit Motor | \$5,000 | 2 | EA | 10 | \$10,000 | \$1,000 |
| 7 | Bar Screen Scraper | \$5,000 | 2 | EA | 10 | \$10,000 | \$1,000 |
| 8 | SBR Blowers | \$7,500 | 3 | EA | 10 | \$22,500 | \$2,250 |
| 9 | Air Compressor | \$5,000 | 2 | EA | 15 | \$10,000 | \$667 |
| 10 | Diffusers | \$1,000 | 10 | EA | 10 | \$10,000 | \$1,000 |
| 11 | UV Lamp Bank | \$1,100 | 2 | EA | 2 | \$2,200 | \$1,100 |
| 12 | Polymer Feed Pumps for Sludge Dewatering | \$3,500 | 2 | EA | 10 | \$7,000 | \$700 |
| 13 | Sludge Pumps | \$2,000 | 2 | EA | 10 | \$4,000 | \$400 |
| 14 | Security Cameras & Alarms | \$3,500 | 1 | LS | 10 | \$3,500 | \$350 |
| 15 | Collection System Lift Station Pumps | \$15,000 | 4 | EA | 15 | \$60,000 | \$4,000 |
| 16 | Collection System Valving | \$2,500 | 18 | EA | 20 | \$45,000 | \$2,250 |
| TOTAL ANNUAL REPLACEMENT VALUE | | | | | | | \$27,884 |

7.6.2 Reserves

In order to maintain financial stability and self-sufficiency and to achieve both long- and short-term capital and operational needs into the future, the District will need to maintain financial-reserve funds. The financial reserve funds shall be used for:

- general operating reserves
- replacement reserves for short lived capital improvements and emergency maintenance
- debt reserve fund required by most long-term debt, to provide a reserve that will ensure payment
- capital reserve fund (optional)

General Operating Reserve Fund

An operating reserve compensates for cash flow variations. There can be a significant length of time between when a system provides a service and when a customer may pay for the service



rendered. In addition to timing, the volume of cash flow can be affected by weather and seasonal demand patterns. Wastewater agencies in California normally operate with reserves of between 10 and 50 percent of annual revenue requirements. A 45-day (approximately 6 weeks) operating reserve is a frequently used industry norm. The operating reserve can also cover costs of unplanned expenses, other than emergencies, such as, increase in electrical or operational costs; costs caused by leaks; extra callouts, late payments, etc.

A 20% operating reserve, based upon the projected O&M budget would be \$43,400.

For budgeting purposes, this reserve fund will be built up over a five year period, after which annual contributions will not be required. The five years, annual contribution would be \$8,680

Replacement Reserve Fund

A capital improvement reserve is for short lived capital improvements, including system rehabilitation, equipment replacement, as well as on-hand cash for emergency equipment replacement, if necessary. Short lived assets for the purpose of this report are those assets which will require replacement prior to the end of the anticipated financing cycle for the project. For this report that period is 30 years.

Projected replacement reserves, based upon the short lived asset inventory, would be \$27,880.

Debt Reserve Fund

A debt reserve fund is required by most long-term debt, to provide a reserve that will ensure payment. If money was borrowed to build the system, money will have to be placed into a debt service reserve account until an agreed upon dollar amount is reached. A debt service reserve is in addition to a loan repayment. The debt service reserve helps ensure timely payments can be made even if there is a financial emergency

See Debt Service Section Below for projections.

Capital Reserve Fund (optional)

Communities are encouraged to establish a capital reserve fund. This fund is intended to provide funds for replacement of facilities after they serve their useful life. The capital reserve fund includes: connection fees, capacity charges, development charges, wastewater impact fees and any other charge imposed on new construction, wastewater agencies in California normally operate with reserves of between 10 and 50 percent of annual revenue requirements.

Considering the District's wastewater collection, treatment, and disposal system will be, for the most part, all brand new facilities; at this time, no capital reserve fund is being considered. To establish and fund the capital reserves properly, the District will need to develop policy and plans associated with long-term replacement. The District should consider adopting various fees and charges listed above.

At this time, no capital reserve fund is being considered.



7.6.3 Debt Service

Debt service is the annual sum of the principal and interest payments on proposed or outstanding obligations secured by bonds or loan contracts.

The amount of debt service associated with the proposed project will be dependent upon the financing package the District can acquire. The most advantageous state and federal programs to be pursued for funding the project consist of the following:

State Water Board Financial Assistance Programs

The Division of Financial Assistance (DFA) administers the implementation of the SWRCB financial assistance programs that include loan and grant funding for construction of municipal sewage and water recycling facilities. The state's loan program offers low interest loans to qualified communities for funding clean water projects. The state's Small Community Grant Fund (SCG) allows the SWRCB to help finance communities with the most need in California, helping those that cannot otherwise afford a loan or similar financing to move forward with water quality improvements. State law requires the SWRCB to give grant priority to projects that serve severely disadvantaged communities (SDACs), defined as communities with a median household income (MHI) of less than 60 percent of the statewide MHI. Grants are available to fund 50, 75, or 100 percent of the project dependent upon the Community MHI and wastewater rates as a percentage of MHI. The communities of Fairhaven and Finntown would qualify for 100 percent grant funding through this program.

US Department of Agriculture, Rural Development Program

The Rural Development Program of the United States Department of Agriculture (USDA) also administers a loan and grant program, which provides affordable funding to develop essential community facilities in rural areas. An essential community facility is defined as a facility that provides an essential service to the local community for the orderly development of the community in a primarily rural area, and does not include private, commercial, or business undertakings. Rural areas including cities, villages, townships, and towns (including Federally Recognized Tribal Lands) with no more than 20,000 residents according to the latest U.S. Census data are eligible for this program. The USDA program targets small and low-income communities. Grants are available to fund 15, 35, 55, or 75 percent of the project dependent upon community size and MHI.

Community Development Block Grant

Community Development Block Grant (CDBG) funds are allocated to local and state governments on a formula basis. CDBG projects must be consistent with broad national priorities for CDBG: activities that benefit low- and moderate-income people, the prevention or elimination of slums or blight, or other community development activities to address an urgent threat to health or safety. To be eligible for funding, at least 51 percent of the funds awarded shall benefit the targeted income group. No activity or portion of a program assisted by these funds may exclude from its benefits the lowest targeted income group. Individual activities shall meet one of the following three national objectives: 1) the development of viable urban communities by providing decent housing and a suitable living environment and expanding economic opportunities, principally for persons of low-



and moderate-income; 2) aiding in the prevention or elimination of slums or blight; or 3) meeting other community development needs having a particular urgency.

Projected Debt Service

Considering a projected project cost of \$12,313,000, debt service for four funding scenarios was considered. Table 7-9 presents the four funding scenarios and associated debt service under both existing EDU's and with Phase 1 of the Town of Samoa expansion included, as this build-out is expected to occur within a year or two of the development of a consolidate wastewater treatment system on the Samoa peninsula.

Table 7-9: Funding Scenarios

Existing EDUs - 232

| Item | Funding Scenario | | | |
|----------------------------------|------------------|-------------|--------------|--------------|
| Grant Funding Level | 100% | 75% | 50% | 0% |
| Loan Funding Level | 0% | 25% | 50% | 100% |
| Annual Debt Service ¹ | \$0 | \$141,152 | \$282,304 | \$564,609 |
| Monthly Cost/EDU | \$0 | \$51 | \$101 | \$203 |

Existing EDUs w/ Phase 1 Samoa Expansion - 338

| | | | | |
|-------------------------|------------|-------------|-------------|--------------|
| Monthly Cost/EDU | \$0 | \$35 | \$70 | \$139 |
|-------------------------|------------|-------------|-------------|--------------|

1. Debt service figures represent a loan period of thirty years and an interest rate of 1.8%.

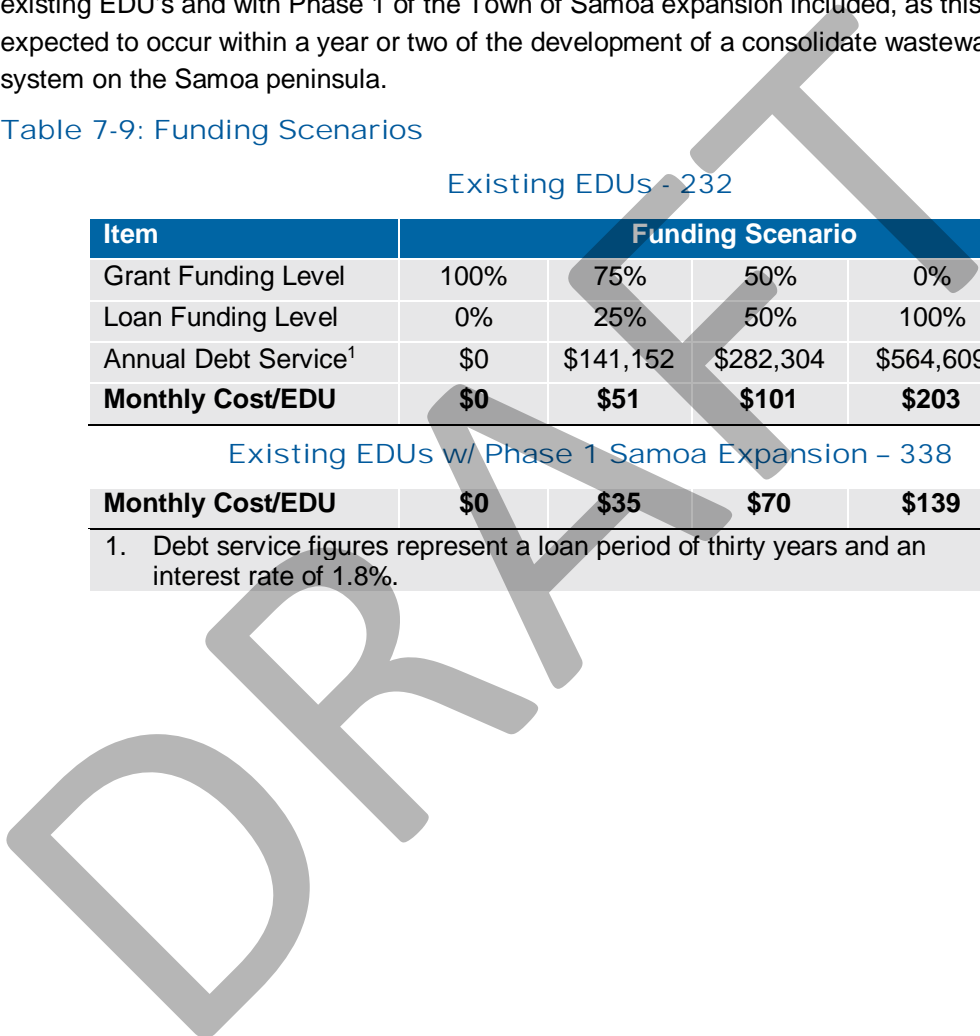



7.6.4 Preliminary Rate Schedule

Considering both the existing EDUs and including Phase 1 of the Town of Samoa expansion the initial projected monthly user rate per EDU is presented in Table 7-10.

Table 7-10: Projected Monthly User Rate per EDU

Existing EDUs - 232

| Item | Cost per EDU | |
|---------------------------|--------------|--------------|
| | 100% Grant | 75% Grant |
| O&M | \$77 | \$77 |
| Operating Reserve | \$3 | \$3 |
| Replacement Reserve | \$10 | \$10 |
| Debt Service | \$0 | \$51 |
| Total Monthly Rate | \$90 | \$141 |

Existing EDUs w/ Phase 1 Samoa Expansion - 338

| Item | Cost per EDU | |
|---------------------------|--------------|-------------|
| | 100% Grant | 75% Grant |
| O&M | \$53 | \$53 |
| Operating Reserve | \$2 | \$2 |
| Replacement Reserve | \$7 | \$7 |
| Debt Service | \$0 | \$35 |
| Total Monthly Rate | \$62 | \$97 |

The projected sewer rate of \$62 with 100% grant funding of the capital construction costs is within the range of rates for the local area (Table 7-11). Without 100% grant construction funding, the rates would be well above the local area rates, may not be sustainable, and may prevent community support and acceptance of this proposed wastewater treatment system. It is vital that the capital costs be covered in full to make the project economically feasible and sustainable in the long term.

Table 7-11: Comparison of the monthly sewer rate per single residence releasing 100 cubic feet of wastewater for the local municipalities and community services districts.

| Community | Monthly Sewer Rate |
|-------------------------|--------------------|
| City of Arcata | \$49 |
| City of Eureka | \$30 |
| McKinleyville CSD | \$37 |
| Proposed Town of Samoa | \$50 |
| Fieldbrook-Glendale CSD | \$70 |
| Humboldt CSD | \$25 |
| Manila CSD | \$40 |



7.7 Community Engagement

Four public outreach meetings are planned at which the project will be presented to residents and land owners of the affected project area. The first public outreach meeting was held in January 2018 and introduced the project to affected residents and land owners, including an overview of the planning effort, project purpose, funding process, and design and siting criteria. Three additional public outreach meetings are planned, including one as part of the CEQA EIR process.

The EIR process provides several key stages specifically for public input. Public participation usually consists of two types of input: scoping (providing input on the range of environmental issues to be addressed in the CEQA document), and review and comment (comments to the lead agency on the adequacy of the draft CEQA document before it is certified). When the lead agency determines that an EIR is required, it will issue a Notice of Preparation (NOP). The purpose of the NOP is to invite input from the public and relevant agencies on the environmental topics to be addressed in the EIR. This process is called scoping. When the Draft EIR is complete, the lead agency will make it available for public review & comment. Copies will be available online, at the lead agency, and at the local library. They will also be available for purchase in CD or printed form from the lead agency. Comments may be submitted for a period of 45 days. Prior to any formal action on the project, the lead agency and/or its EIR consultant will prepare written responses to all comments. The Response to Comments package will be available to the public before the noticed hearing when decision-makers consider the final step in the process--certifying that the Final EIR is adequate and complete.

The Proposition 218 rate approval process, which is intended to ensure that all taxes and most charges on property owners are subject to voter approval, would be a part of the construction phase of the project, after funding has been obtained. A detailed rate study will be completed as part of the 218 process. The preliminary rate study presented in this report will be refined based on the grant and loan funding obtained for the project construction. A written notice of public hearing will be prepared and mailed to the recorded owner of each parcel upon which the fee will be imposed. A public hearing will then be held 45 days or more after the notice is mailed. At the public hearing all public comments on the proposed fee will be heard and considered. Upon the conclusion of the public hearing, if written protests against the proposed fee are not presented by the majority of property owners of the identified parcels, then the fee will be implemented.

7.8 Project Schedule

The next year of the project schedule, 2018, focus will be on finishing the environmental review, permit preparation, and obtaining funds for the final design and construction of the Samoa Peninsula Wastewater Treatment Plant. Then in 2019 focus will be on executing the final studies and design of the system, with project construction in 2020. Permitting will begin as studies and designs are finalized and will continue through the early stages of bidding and construction.

- | | |
|---------------------------------------|------------------------------|
| 1. CEQA / EIR | January 2018 – December 2018 |
| 2. Preliminary Permitting Preparation | June 2018 – October 2018 |
| 3. PCSD Waste Discharge Requirements | August 2018 – October 2018 |



| | |
|--|------------------------------|
| 4. Construction Grant/Loan Application | October 2018 – December 2018 |
| 5. Execute Grant/Loan Agreement | March 2019 |
| 6. Funding and Rate Analysis | April 2019 – May 2019 |
| 7. Prop 218 Process | April 2019 – July 2019 |
| 8. Topographic Survey | March 2019 – December 2019 |
| 9. Geotechnical Investigation | May 2019 – October 2019 |
| 10. Collection System & Treatment Plant Design | April 2019 – December 2019 |
| 11. Permitting | July 2019 – March 2020 |
| 12. Bidding & Construction | January 2020 – January 2021 |

8. Conclusions, Recommendations, and Next Steps

This preliminary engineering report has analyzed alternatives for providing community sewer service to the Samoa Peninsula. The apparent best project includes a reliable treatment and disposal system that should be easy to operate and maintain.

This PER has been completed with funds received from the SWRCB, Clean Water State Revolving Fund Small Community Planning Grant. This grant was awarded in July 2017. GHD and SHN have been working with the Peninsula CSD to complete this PER. The following next steps are scheduled to occur, using the remaining grant funds.

8.1 Next Steps within Current Grant

1. An EIR, as outlined by Title 14 of CEQA, for the Samoa Peninsula Wastewater Project will begin after the approval of the PER by the County and the District Board. The EIR process will address and evaluate the potential environmental impacts of the project and incorporate mitigation measures where feasible.

A required and critical piece of the EIR process is public input. CEQA does not require public meetings at any stage of the environmental review process; however, an initial scoping meeting and a public hearing on the Draft EIR are recommended and will be conducted as part of this process. These meetings will provide the opportunity to inform the public of the project, and receive input on environmental issues associated with the project.

2. The construction of a combined WWTP site at the existing Samoa townsite WWTP location will require an LCP amendment to the Samoa Town Master Plan in the Humboldt Bay Area Plan. Discussion should be conducted with the CCC and SPG to instigate this update. Alternatively, the WWTP site could be moved to the RMT-II if the zoning of this site is successfully changed to General Industrial. Discussions should continue with the Humboldt Bay Harbor, Recreation and Conservation District, the CCC and Humboldt County on this alternative.



3. SHN will complete a report of waste discharge (ROWD) application for the District, which is a necessary part of the wastewater system development and implementation. The NCRWQCB will issue a new NPDES permit and associated WDRs, which will be based in part on the ROWD, which will describe the new collection system, treatment facilities, and disposal practices. This process includes completion of Form 200 which is submitted to the state.
4. Submit funding applications to federal and state agencies. GHD will assist the District in the completion of the grant applications for final design and construction funds. The level of grant funds received will determine the actual user costs for the project

DRAFT



9. References

- Anderson, Kathy, December 1, 2017. Personal Communication: Peninsula Union School District
- ASCE/WPCF, 1982. *Gravity Sanitary Sewer Design and Construction*. New York, NY: ASCE; Washington, DC:WPCF.
- Bobillot, Alan, November 14, 2017. Personal Communication: HBHRCD.
- California Engineering Company (CEC), 2015. *Application/Report of Waste Discharge - Town of Samoa - 4th Submittal*. Yuba City, CA:CEC.
- Callison, Tim, November 20, 2017. Personal Communication: Security National.
- CEC, 2015a. *Plan for Services for Reorganization of the Samoa Peninsula Fire Protection District*. Yuba City, CA:CEC.
- CEC, 2015b. *Samoa Peninsula Fire District Fiscal Analysis- Data Sheets for Possible LAFCo Reorganization*. Yuba City, CA:CEC.
- CEC, 2017. Personal Communication: David Swartz, February 27, 2017.
- City of Eureka, 2016. 2015 Urban Water Management Plan for the City of Eureka, California. DEH, 2017. *Personnel Communication: Interview with DEH Staff Carolyn Hawkins 10/20/2017*.
- Clarke Museum, 2017. *Ship Building in Humboldt County*. Website accessed 1/24/2018. Accessed at: <http://www.clarkemuseum.org/4-past-exhibits/ship-building-in-humboldt-county>
- Clearwater Group, 2002. *Site Plan, Fairhaven Fire Protection District, 1982 Gass Street, Fairhaven, California*. Website accessed 1/25/2018. Accessed at: https://geotracker.waterboards.ca.gov/profile_report.asp?global_id=T0602300227
- Colton, Tim, 2017. *Bendixsen Shipbuilding, Fairhaven CA*. Website accessed 1/24/2018. Accessed at: <http://shipbuildinghistory.com/shipyards/19thcentury/bendixsen.htm>
- Cosmopolitan Marine Engineering, 2016. *Humboldt Mill Outfall Evaluation*. Technical Memorandum from Bill Fox (CME) to Dave McEntee (Simpson Paper Company); October 7, 2016. Gig Harbor, WA:CME.
- County of Humboldt, 2006. *Samoa Town Master Plan Draft Environmental Impact Report*.
- Davis, 2010. *Water and Wastewater Engineering: Design Principles and Practice*. The McGraw-Hill Companies, Inc. New York, NY.
- Department of the Army, 2011. *No DOD Action Indicated (NDAI), Former Section Air Base, Sea Plan Base, and Lighter Than Air Base, (J09CA7268), Humboldt County, CA*.
- Drop, Chris, January 9, 2018. Personal Communication. Manila Community Services District.
- EPA, 1991. Manual, Alternative Wastewater Collection Systems. EPA/625/1-91/024.



HCDEH, 2017. Personnel Communication: Interview with HCDEH Staff Carolyn Hawkins 10/20/2017.

Holmlund, Robert, October 11, 2017. Personal Communication: Director of Development Services, City of Eureka.

Humboldt Bay Municipal Water District, 2016. *Humboldt Bay Municipal Water District Consumer Confidence Report*. Eureka, CA:HBMWD.

Humboldt Bay Social Club Website. Accessed 11/11/17 at:
<https://www.humboldtbausocialclub.com/>.

Humboldt Community Services District, 2016. *Water and Sewer Design and Construction Standards, Second Revision*. Eureka, CA:HCSD.

Humboldt County, 2006. *Samoa Town Master Plan Draft Master Environmental Impact Report*.

Humboldt County, 2017. *Humboldt County Web GIS*, accessed November 28, 2017. Accessed at:
<http://webgis.co.humboldt.ca.us/HCEGIS2.0/>

Humboldt County, (NR). Humboldt County Website. accessed 11/14/17 at:
<http://www.humboldt.gov/Facilities/Facility/Details/Samoa-Boat-Ramp-9>.

JM Eagle, 2017. Does JM Eagle's SDR 35 gravity sewer pipe meet the various required industry standards? Website visited February 10, 2018. Website address: <http://www.jmeagle.com/does-jm-eagles-sdr-35-gravity-sewer-pipe-meet-various-required-industry-standards>

LACO Associates, 2013. *Phase I Environmental Site Assessment Report, 1 TCF Drive, Samoa, California, Assessor's Parcel Number 401-112-021*. Eureka, CA:LACO.

LACO Associates, 2013a. *Samoa Industrial Waterfront Preliminary Transportation Access Plan*. Eureka, CA:LACO.

Maeda, Richela, October 31, 2017. Personal communication with GHD, re. Excerpts from Tsunami Preparedness Planning.

Manley, Christopher, October 3, 2017. Personal Communication: Perciformes Group LLC.

Metcalf & Eddy. 2014. *Wastewater Engineering Treatment and Resource Recovery*. 5th Ed. New York, NY:McGraw-Hill.

NCRWQCB, 2017. *Facility At-A-Glance Report: DG Fairhaven Power*. Website accessed December 13, 2017. Accessed at:
<https://ciwqs.waterboards.ca.gov/ciwqs/readOnly/CiwqsReportServlet?inCommand=drilldown&reportName=facilityAtAGlance&placeID=613197&reportID=4657435>. Santa Rosa,CA:NCRWQCB.

NCRWQCB, 2017a. *Facility At-A-Glance Report: Samoa Town Site*. Website accessed December 13, 2017. Accessed at:
<https://ciwqs.waterboards.ca.gov/ciwqs/readOnly/CiwqsReportServlet?inCommand=drilldown&reportName=facilityAtAGlance&placeID=255165&reportID=7146867>. Santa Rosa,CA:NCRWQCB.



- NCRWQCB, 2014. *Waste Discharge Requirements for Samoa Pacific Group, LLC. Order No. R1-2014-0031, WDID No. 1B85017RHUM.* Humboldt County, CA. Accessed at https://www.waterboards.ca.gov/northcoast/board_info/board_meetings/11_2014/pdf/samoa/14_0031_Draft_Samoa_WDR.pdf
- NCRWQCB, 2011. *Water Quality Control Plan for the North Coast Region.* Santa Rosa, CA:NCRWQCB.
- NCRWQCB, 2013. *Water Quality Control Policy for Siting, Design, Operation, and Maintenance Onsite Wastewater Treatment Systems.* Santa Rosa,CA:NCRWQCB.
- Northern Hydrology & Engineering, 2015. *Humboldt Bay: Sea Level Rise, Hydrodynamic Modeling, and Inundation Vulnerability Mapping, Final Report.* McKinleyville, CA:NHE.
- O'Conner, Jon, November 27, 2017. Personal Communication: Humboldt Bay Social Club.
- SHN, 1998. *Groundwater Investigation: Samoa Pulp Mill.* Eureka, CA:SHN.
- SHN, 2011. *Conceptual Site Model: Former Louisiana-Pacific Pulp Mill.* Eureka, CA:SHN.
- SHN, 2015. *Groundwater Modeling Report: Proposed Wastewater Treatment Facility, Samoa, California.* Eureka, CA:SHN.
- SHN, 2016. *Infrastructure Needs and Reuse on the Samoa Peninsula: Redwood Marine Terminal II.* Eureka, CA:SHN.
- SHN, 2017a. *Management Plan, Peninsula CSD Formation.* Eureka, CA:SHN.
- SHN, 2017b. Personal Communication: Christopher Manley, Perciformes Group. October 3, 2017.
- SHN, 2017c. *Report of Waste Discharge, Town of Samoa Wastewater Treatment Facility.* Eureka, CA:SHN.
- SHN, 2017d. *Samoa Pulp Mill Infrastructure Analysis: Redwood Marine Terminal II.* Eureka, CA:SHN.
- SHN, 2017e. *Wastewater Collection System Rainfall-Derived Infiltration and Inflow Reduction Plan and Capital Improvement Plan.* Eureka, CA:SHN.
- SHN, 2017f. *Wetland Delineation, RMT-II Samoa Effluent Pipeline.* Eureka, CA:SHN.
- Sollom, Brian, November 27, 2017. Personal Communication: Recology.
- Spector, Robert. 1990. *Family Tree: Simpson's Centennial Story.* Documentary Book Publishers Corporation: Bellvue, WA.
- Timber Heritage Association, 2018. *Samoa (West Eureka).* Website accessed 1/24/2018. Accessed at: <http://timberheritage.org/timber-company-towns/samoa/>
- US Census Bureau, 2010. *Profile of General Population and Housing Characteristics: 2010, Samoa CDP, California.*
- USEPA, 2002. *Onsite Wastewater Treatment Systems Manual.* EPA/625/R-00/008.



All of which is Respectfully Submitted,

Patrick Kaspari, PE, GHD



Mike Foget, PE, SHN



DRAFT



DRAFT

Appendices

DRAFT



Appendix A – Wetland Delineation:
RMTII Samoa Effluent Pipeline
Samoa, California
SHN, 2017

DRAFT

DRAFT



Appendix B – WDR No. R1-2001-62
Town of Samoa Wastewater Treatment
Facilities

DRAFT

DRAFT



Appendix C – WDR No. R1-2012-0027
DG Fairhaven Power Facility

DRAFT

DRAFT



Appendix D – Town of Samoa Wastewater Flow and
Dispersal Area Study
CEC, 2015

DRAFT

DRAFT



Appendix E – National Primary Drinking Water
Regulations
USEPA

DRAFT

DRAFT



Appendix F – Treatment System Cost Estimates

DRAFT

DRAFT



Appendix G – EcoCycle SBR Details

DRAFT

DRAFT



Appendix H – Trojan UV Fit Details

DRAFT



DRAFT

Appendices

DRAFT



Appendix A – Wetland Delineation:
RMTII Samoa Effluent Pipeline
Samoa, California
SHN, 2017

DRAFT

DRAFT

Wetland Delineation

RMTII Samoa Effluent Pipeline Samoa, California

Prepared for:

**County of Humboldt and
Humboldt Bay Harbor, Recreation, and Conservation District**

Project Funding Provided by:

U.S. Department of Commerce 07-79-07177

DRAFT

SH Engineers & Geologists

812 W. Wabash Ave.
Eureka, CA 95501-2138
707-441-8855

March 2017
015147.100

Wetland Delineation

RMTII Samoa Effluent Pipeline Samoa, California

Prepared for:

**County of Humboldt and
Humboldt Bay Harbor, Recreation, and Conservation District**

Project Funding Provided by:

U.S. Department of Commerce 07-79-07177

Prepared by:



Engineers & Geologists
812 W. Wabash Ave
Eureka, CA 95501-2138
707-441-8855

March 2017

QA/QC: JLS/cg___

Table of Contents

| | Page |
|--|------|
| List of Illustrations | ii |
| Abbreviations and Acronyms | iii |
| 1.0 Introduction | 1 |
| 1.1 Purpose..... | 1 |
| 1.2 Project Location..... | 1 |
| 2.0 Project Description..... | 1 |
| 3.0 Environmental Setting..... | 1 |
| 4.0 Vegetation..... | 2 |
| 5.0 Geologic and Soil Composition..... | 3 |
| 6.0 Regulatory Setting | 5 |
| 6.1 Federal Laws..... | 5 |
| 6.1.1 Section 401 and 404 of the Clean Water Act..... | 5 |
| 6.1.2 Rivers and Harbors Appropriation Act of 1899 | 6 |
| 6.2 State Laws | 6 |
| 6.2.1 Porter-Cologne Water Quality Act..... | 6 |
| 6.2.2 California Coastal Act..... | 6 |
| 7.0 Methodology..... | 7 |
| 7.1 Vegetation Methodology | 8 |
| 7.2 Soils Methodology | 9 |
| 7.3 Hydrology Methodology..... | 9 |
| 7.4 Ordinary High Water Mark Methodology..... | 9 |
| 8.0 Discussion and Results..... | 10 |
| 8.1 TP1 Test Site..... | 10 |
| 8.1.1 Discussion | 10 |
| 8.1.2 Data..... | 10 |
| 8.2 TP2 Test Site..... | 11 |
| 8.2.1 Discussion | 11 |
| 8.2.2 Data..... | 11 |
| 8.3 TP3 Test Site..... | 11 |
| 8.3.1 Discussion | 11 |
| 8.3.2 Data..... | 12 |
| 8.4 TP4 Test Site..... | 12 |
| 8.4.1 Discussion | 12 |
| 8.4.2 Data..... | 12 |
| 8.5 TP5 Test Site..... | 13 |
| 8.5.1 Discussion | 13 |
| 8.5.2 Data..... | 13 |
| 8.6 TP6 Test Site..... | 14 |
| 8.6.1 Discussion | 14 |
| 8.6.2 Data..... | 14 |

Table of Contents. Continued

| | Page |
|---|------|
| 8.7 Ordinary High Water Mark (OHWM)..... | 14 |
| 8.8 National Wetlands Inventory (NWI) | 14 |
| 9.0 Conclusions..... | 15 |
| 10.0 Limitations | 16 |
| 11.0 References Cited..... | 16 |

Appendices

- A. National Wetlands Inventory
- B. Site Photographs
- C. Plant List
- D. Wetland Determination Data Forms

List of Illustrations

| Figures | Follows Page |
|--------------------------------------|--------------|
| 1. Project Location Map..... | 1 |
| 2. Delineated Wetlands Site Map..... | 1 |

| Tables | On Page |
|--|---------|
| 1. Climate Analysis for Wetlands Table (WETS) Rainfall Data..... | 2 |
| 2. Wetland Delineation Results..... | 16 |

Abbreviations and Acronyms

| | |
|-------|---|
| APN | Assessor's parcel number |
| CFR | Code of Federal Regulations |
| CT | control point |
| CWA | Clean Water Act |
| DI | drainage inlet |
| EPA | United States Environmental Protection Agency |
| FAC | facultative wetland plant species |
| FACU | facultative-upland wetland plant species |
| FACW | facultative-wet wetland plant species |
| GIS | geographic information system |
| GPS | global positioning system |
| NL | not listed plant species |
| NRCS | Natural Resources Conservation Service |
| NWI | National Wetlands Inventory |
| OBL | obligate wetland plant species |
| OHWM | ordinary high water mark |
| QISP | Qualified Industrial Stormwater Practitioner |
| Redox | redoximorphic |
| RWQCB | California Regional Water Quality Control Board |
| SHN | SHN Engineers & Geologists |
| SWRCB | State Water Resources Control Board |
| TP | test pit |
| UPL | upland wetland plant species |
| USACE | United States Army Corps of Engineers |
| USC | United States Code |
| USDA | United States Department of Agriculture |
| USGS | United States Geological Survey |
| WDRs | waste discharge requirements |
| WETS | Climate Analysis for Wetlands Tables |
| WoS | waters of the State |
| WoUS | waters of the United States |

1.0 Introduction

SHN Engineers & Geologists has prepared this preliminary jurisdictional wetland delineation for the RMTII Samoa Effluent Pipeline. Fieldwork was performed by SHN staff.

1.1 Purpose

The purpose of this report is to identify potential wetlands and other waters of the United States and State at the project site, as defined by the United States Army Corps of Engineers (USACE) methodology. The delineation of these features will help guide the design and construction of future development within the study area and avoid impacts to potential wetlands.

1.2 Project Location

The project is located in Samoa, California, an unincorporated community within Humboldt County (Figure 1; United States Geological Survey [USGS] Eureka 7.5-minute Quadrangle, Township 5 North, Range 1 west, Sections 15, 16, and 17, Humboldt Meridian). The project is located across 10 adjacent parcels; (APN 401-031-039, 059, 061, 065, 067, 068 and 401-112-003, 021, 022, and 023) however the wetland delineation took place within a limited area of potential effects surrounding the proposed pipeline alignment. The area of potential effects (APE) includes a 100 foot wide right of way surrounding the proposed pipeline alignment as well as two widened areas at each end for staging (Figure 2). The proposed pipeline has an approximate length of 3,200 feet with an APE of approximately 23 acres. The majority of the project occurs within the Vance Avenue and railroad right of way (APN 401-031-039 and 401-112-003) The wetland delineation took place within the 23 acre APE with a central location at latitude and longitude 40.811009° and -124.195243° (County of Humboldt GIS 2017). The wetland delineation was approximately 250 feet east of New Navy Base Road at its nearest point, and approximately 1,130 feet west of Humboldt Bay at its nearest point, and 1 air mile west of the City of Eureka.

2.0 Project Description

Environmental management constraints are being considered for the study area. This report will assist in considering site management options.

3.0 Environmental Setting

The study area is situated at an approximate 15-32 foot elevation above mean sea level (See Figures 1 and 2 and Appendix A). The study area has been used for industrial purposes since the 1960s. Several lumber mills operated on the northern portion of the site closing at different times within the last 20 years. These facilities have mostly been demolished leaving vacant industrial land. The southern portion of the project area has been the location of a pulp mill from the 1960s until 2008 when it closed. The area still contains structures from the shuttered mill; however, the majority of the site is composed of broad stretches of vacant asphalt with some small scale industrial use continuing on site. The western portion of the project area passes by an industrial recycling facility that will be skirted by the proposed effluent pipeline. Currently, the majority of the project area is covered in old asphalt, broken up concrete, compacted gravel within former log decks, and railroad infrastructure. Small areas of semi-natural dune habitat occur between the vacant industrial lands

\\Eureka\Projects\2015\015147-redwood-marine-terminal-II\100-NPDES-permit\GIS_PROJ_MXD\Wetland_Fig1_ProjectLocation.mxd;User:jsousa;Printed:3/31/2017



SHN
Consulting Engineers
& Geologists, Inc.

Humboldt Bay Harbor District
 Samoa Effluent Pipeline, RMT II
 Samoa, California

Project Location
 SHN 015147.100

March 2017

Wetland_Fig1_ProjectLocation

Figure 1

Copyright:© 2013 National Geographic Society, i-cubed

\\Eureka\Projects\2015\015147-redwood-marine-terminal-II\100-NPDES-permit\GIS\PROJ_MXD\Wetland_Fig2_DelineationResults.mxd User Name: jsousa



DRAFT

in areas that were used as drainages, or along property lines. The area is characterized by a mix of disturbance-adapted, primarily non-native, herbaceous species, along with shrub dominated regions, and areas with higher native vegetation cover. The native vegetation dominated communities usually had an overstory dominated by coast willow (*Salix hookeriana*) and California wax-myrtle (*Morella californica*), indicating a longer period since it was last disturbed. Vegetation encroachment has been limited within areas of concrete, asphalt and compacted gravel, however these areas were not typically the location of wetlands. It was not necessary to excavate test pits in areas without vegetation cover, due to a lack of wetland features in those areas (See Figure 2, Appendix A, and Appendix B, Photos B1-8 for site description). Nearly the entire project area has been manipulated at some point in the past and continues to be manipulated, as evidenced by on-going vegetation maintenance, equipment movement and some continued industrial use.

Field investigations were conducted March 23, and 24, 2017. The average annual 30-year precipitation data for this area from 1981 to 2010 is 40.33 inches (NOAA Woodley Island Station, 2017). The March 24, 2017 total since October 1, 2016 was 54.56 inches (NOAA, 2017), indicating that the 2016/2017 rain season is above average. Rainfall for the first three weeks of March 2017, prior to the initiation of the field investigation, was higher than normal, with several wet rainy days preceding the two days of field work. The United States Department of Agriculture-Natural Resources Conservation Service (USDA-NRCS) Climate Analysis for Wetlands Table (WETS) reviews the previous three months before the investigation (or the same month and two prior if after the 15th) to determine precipitation conditions at the time of the delineation. The WETS table analysis indicates that the three most recent months are considered a wetter than normal rainfall period (Table 1; USDA-NRCS, 2017).

| Month | WETS data | Rank | Weight | Value |
|---|------------------|-------------|---------------|--------------|
| March 2017 | Wet | 3 | 3 | 9 |
| February 2017 | Wet | 3 | 2 | 6 |
| January 2017 | Wet | 3 | 1 | 3 |
| Total¹ | | | | 18 |
| 1. A sum of 6-9 prior to site investigation is considered a drier than normal rainfall. 10-14 prior to site investigation is considered a normal rainfall. 15-18 prior to site investigation is considered a wetter than normal rainfall. | | | | |

4.0 Vegetation

The study area consists of a generally flat graded surface, sloping in different directions throughout the project area along the proposed effluent pipeline alignment, with a primarily west to east slope. There is considerable coverage of non-native species, with the majority of the project area dominated by non-native grassland interspersed with asphalt, concrete and gravel areas. Dominant species within the non-native grassland included large quaking grass (*Briza maxima*; upland, [NL]), velvet grass (*Holcus lanatus*; facultative [FAC]), small fescue (*Festuca microstachys*; [NL]), birds-foot trefoil (*Lotus corniculatus*; [FAC]), sweet vernal grass (*Anthoxanthum odoratum*; facultative upland [FACU]), pampas grass (*Cortaderia jubata*; FACU) and iceplant (*Carpobrotus edulis*; [FAC]). Less disturbed areas had a shrub layer dominated by coyote brush (*Baccharis pilularis*; upland [NL]), yellow bush lupine (*Lupinus arboreus*; [NL]), and California blackberry (*Rubus ursinus*; [FACU]) in

thickets. A tree layer existed in two locations along the proposed pipeline alignment. These areas were dominated by coast willow [FACW] and California wax myrtle [FAC]. These areas are not proposed to be impacted by the project, but were investigated for wetland conditions to establish correct buffer distances during the construction of the project. A complete list of plants observed within the study area is compiled in Table C-1 in Appendix C.

5.0 Geologic and Soil Composition

The site is set on coastal dunes on a narrow spit of land between Humboldt Bay and the Pacific Ocean. The majority of the project area has been manipulated for industrial development which included the importation of industrial fill material, grading of the site, and installation of utilities. The Samoa spit and dune features developed over time from mixed alluvium from adjacent rivers deposited by prevailing ocean currents. Dune features shift naturally over time with the introduction of additional sediment deposits and prevailing wind patterns. Older dunes further inland become stabilized as vegetation colonizes exposed sand. Deflation basins become established as prevailing winds continue to develop drift deposits. It is within the deflation basins that natural dune wetlands form. The majority of the natural dune landscape has been removed within the project area for industrial development, however natural wetland systems were observed within the area. The majority of wetland conditions expected within the area of potential effects are expected to be a result of improper drainage due to poor slope and grading within the former industrial areas. Various soil colors and textures were found during test pit (TP) analysis that were indicative of numerous sources of fill, which did not fit with the surrounding soil matrix. Other areas contained colors and textures that appeared to represent more natural dune soils.

The underlying soils in the project site have a USDA classification of Samoa-Clambeach-Duneland complex, 0 to 50 percent slopes (map unit 155) and industrial fill (NOTCOM). Due to the unknown source of fill found onsite, these descriptions are the general depiction of what may be encountered. The actual soil description at each exploratory soil TP is described in the field data forms found in Appendix D.

155 – Samoa-Clambeach-Dune land Complex, 0 to 50 percent slopes

Map Unit Composition

Samoa and similar soils: 50 percent

Clambeach and similar soils: 30 percent

Dune land: 15 percent

Minor components: 5 percent

Description of Samoa

Typical profile

Oi - 0 to 1 inches: slightly decomposed plant material

A - 1 to 6 inches: sand

AC - 6 to 18 inches: sand

C - 18 to 63 inches: sand

Properties and qualities

Slope: 2 to 50 percent

Depth to restrictive feature: More than 80 inches

Natural drainage class: Somewhat excessively drained

Runoff class: Medium

Capacity of the most limiting layer to transmit water (Ksat):

High to very high (5.95 to 19.98 in/hr)

Depth to water table: More than 80 inches

Frequency of flooding: None

Frequency of ponding: None

Salinity, maximum in profile: Nonsaline to very slightly saline (0.0 to 2.0 mmhos/cm)

Available water storage in profile: Low (about 3.9 inches)

Description of Clambeach

Typical profile

A - 0 to 9 inches: sand

Cg1 - 9 to 20 inches: sand

Cg2 - 20 to 63 inches: sand

Properties and qualities

Slope: 0 to 2 percent

Depth to restrictive feature: More than 80 inches

Natural drainage class: Very poorly drained

Runoff class: Very high

Capacity of the most limiting layer to transmit water (Ksat):

High to very high (5.95 to 19.98 in/hr)

Depth to water table: About 0 to 4 inches

Frequency of flooding: None

Frequency of ponding: Frequent

Salinity, maximum in profile: Nonsaline to very slightly saline (0.0 to 2.0 mmhos/cm)

Available water storage in profile: Low (about 3.6 inches)

Description of Dune Land

Setting

Landform: Foredunes, dunes

Landform position (two-dimensional): Shoulder, backslope, summit

Landform position (three-dimensional): Tread

Down-slope shape: Linear, convex

Across-slope shape: Linear, convex

Parent material: Eolian and marine sand derived from mixed sources

Properties and qualities

Slope: 2 to 15 percent

Depth to restrictive feature: None within 60 inches

Drainage class: Well drained

Capacity of the most limiting layer to transmit water (Ksat):

Moderately high or high (0.599 to 1.999 in/hr)

Depth to water table: More than 6 feet

Frequency of flooding: None
Frequency of ponding: None
Available water capacity: Moderate (about 8.6 inches)
(USDA, 2017b)

6.0 Regulatory Setting

6.1 Federal Laws

6.1.1 Section 401 and 404 of the Clean Water Act

Under Section 404 (33 U.S. Code [USC] 1344) of the Clean Water Act (CWA), as amended, the USACE and the Environmental Protection Agency (EPA) retain primary responsibility for permits to discharge dredged or fill material into “navigable waters of the United States.” All discharges of dredged or fill material into jurisdictional waters of the United States (WoUS) that result in permanent or temporary losses of WoUS are regulated by the USACE. A permit from the USACE must be obtained before placing fill or grading in wetlands or other WoUS, unless the activity is exempt from CWA Section 404 regulation (for example, certain farming and forestry activities).

In summary, the definition of WoUS as defined by 33 Code of Federal Regulations (CFR) Section 328.3 (U.S. Code of Regulations) includes:

1. waters used for commerce,
2. interstate wetlands,
3. all other waters (including lakes, rivers, streams, mudflats, sandflats, wetlands, sloughs, prairie potholes, wet meadows, playa lakes, and natural ponds),
4. impoundments of water,
5. tributaries to aforementioned waters,
6. territorial seas, and
7. wetlands adjacent to waters.

Under 33 CFR 328.3, WoUS do not include prior converted cropland or waste treatment systems. In 2008, the EPA and USACE released a guidance memorandum implementing the Supreme Court’s decision in the cases of the Rapanos v. U.S. and Carabell v. U.S. Because of these cases, the agencies will apply a significant nexus standard to the following categories to determine if it meets the definition of a WoUS:

- Non-navigable tributaries that are not relatively permanent
- Wetland adjacent to non-navigable tributaries that are not relatively permanent
- Wetland adjacent to but that does not directly abut a relatively permanent tributary

Section 401 of the CWA (33 USC 1341) requires applicants for a federal license or permit to obtain a certification from the state in which the discharge originates or would originate, or if appropriate, from the interstate water pollution control agency having jurisdiction over the affected waters at the point where the discharge originates or would originate, that the discharge will comply with

the applicable effluent limitations and water quality standards. The responsibility for the protection of water quality in California rests with the State Water Resources Control Board (SWRCB) and its nine Regional Water Quality Control Boards (RWQCBs).

6.1.2 Rivers and Harbors Appropriation Act of 1899

The River and Harbors Appropriation Act of 1899 addresses activities that involve the construction of dams, bridges, dikes, and other structures across any navigable water. Placing obstructions to navigation outside established federal lines and excavating from or depositing material in such waters require permits from the USACE Section 10 (33 USC 403) of the Rivers and Harbors Appropriation Act and prohibits the unauthorized obstruction or alteration of any navigable WoUS.

6.2 State Laws

6.2.1 Porter-Cologne Water Quality Act

The state maintains independent regulatory authority over the placement of waste, including fill, into waters of the State (WoS) under the Porter-Cologne Water Quality Act. WoS are defined by the Porter-Cologne Water Quality Act as “any surface water or groundwater, including saline waters, within the boundaries of the state.” The SWRCB protects all waters in its regulatory scope, but has special responsibility for isolated wetlands and headwaters. WoS are regulated by the RWQCBs under the State Water Quality Certification Program, which regulates discharges of dredged and fill material under Section 401 of the CWA and the Porter-Cologne Water Quality Control Act.

Projects that require an USACE permit, or fall under other federal jurisdiction, and have the potential to impact WoS are required to comply with the terms of the Water Quality Certification Program. If a proposed project does not require a federal license or permit, but does involve activities that may result in a discharge to WoS, then the local RWQCB has the option to regulate such activities under its state authority in the form of waste discharge requirements (WDRs) or certification of WDRs. Water Quality Order No. 2004-0004-DWQ specifies general WDRs for dredge or fill discharges to waters deemed by the USACE to be outside of federal jurisdiction under Section 404 of the CWA.

6.2.2 California Coastal Act

The California [Coastal Act](#) includes specific policies that address issues such as shoreline public access and recreation, lower cost visitor accommodations, terrestrial and marine habitat protection, visual resources, landform alteration, agricultural lands, commercial fisheries, industrial uses, water quality, offshore oil and gas development, transportation, development design, power plants, ports, and public works. The policies of the Coastal Act constitute the statutory standards applied to planning and regulatory decisions made by the California Coastal Commission and by local governments, pursuant to the Coastal Act.

7.0 Methodology

Wetland delineation methods described in *U.S. Army Corps of Engineers Wetlands Delineation Manual* (Environmental Laboratory, 1987) and *The Regional Supplement to the Corps of Engineers Wetland Delineation Manual: Western Mountains, Valleys, and Coast Region (Version 2.0)* (USACE, 2010) were used to identify potential wetlands and other waters. The routine method for wetland delineation described in the USACE 1987 manual was used to identify potential wetlands within the study area. The USACE method relies on a three-parameter approach, in which criteria for hydrophytic vegetation, hydric soils, and wetland hydrology must each be met (present at the point of field investigation) to conclude that an area qualifies as a wetland. The wetland delineation was conducted within the coastal zone. Only one wetland parameter must be met for an area to be considered a wetland within the coastal zone.

Hydrophytic vegetation refers to plant species known to be adapted to wetland sites. To classify the hydrophytic plants onsite, the most recent *Western Mountains, Valleys, and Coast 2016 Regional Wetland Plant List* was used (USACE, 2016). Hydric soils are soils that are formed under saturated conditions, flooding, or ponding long enough during the growing season to develop anaerobic conditions in the upper part of the soil profile (USDA, 2010). Wetland hydrology is demonstrated through direct evidence (primary indicators) or indirect evidence (secondary indicators) of flooding, ponding, or saturation for a significant portion of the growing season (USACE, 2010).

TP locations were chosen based on site features such as geomorphic position, ponding, and increasing percentages of hydrophytic vegetation. Due to the highly manipulated nature of the site, and the continued use and size of the study area, pits were excavated to investigate conditions representative of a large area. Using paired pit investigation to ascertain the wetland boundary based on soils was difficult, due to the highly manipulated nature of the soils, however paired pits were excavated whenever possible. Wetland parameters met at each pit often varied widely within a small area, dependent on soil movement, vegetation disturbance, and the nature of fill. At each investigation point determined to lie within a three parameter wetland, the perimeter of the wetland was established based on hydrology, and changes in vegetation composition in addition to exploratory test pits. If a suspected wetland test pit was not determined to be a USACE-designated wetland, no additional analysis was done in the immediate area.

Prior to conducting the field investigation, SHN staff reviewed the USGS topographic quadrangle map (Figure 1); USDA-NRCS Web Soil Survey website (USDA, 2017); and NWI map (USFWS, 2017) (Appendix A). During the field investigation, TPs were characterized at the site for the aforementioned botanical, hydrological, and soil parameters.

TP locations were selected to:

- achieve appropriate coverage and characterization of wetland and upland habitats,
- document potential changes in the vegetative community (such as a shift in the dominant species), and
- determine the approximate boundary line between wetlands and uplands by determining the extent of key wetland criteria (hydrology, hydric soils, and hydrophytic vegetation).

Field investigations were conducted on March 23, and 24. Six (6) individual TPs were excavated to characterize the area and record information for soils, vegetation, and hydrology on USACE Wetland Determination Data Forms (Appendix D). Locations of TPs are shown on Figure 2. Photos of the study area are included in Appendix B.

7.1 Vegetation Methodology

Prior to the field investigation, a review of plant species reported to be within the project area was performed by querying the “Consortium of California Herbaria” (Consortium of California Herbaria, 2017) database records and “Calflora” (Calflora, 2017) and California Native Plant Society (CNPS 2017) observations. It was determined that the site investigation was performed during an above normal rainfall period by reviewing rainfall data (see Section 3.0 and Table 1). Absolute percent cover of each plant species was visually estimated within the TP and within each vegetation stratum. The tree stratum was inspected at a 30-foot radius centered on the TP, the herbaceous and sapling/shrub strata at a 5-foot radius. Botanical nomenclature follows *The Jepson Manual, Vascular Plants of California* (Baldwin et al., 2012) in addition to the online Jepson Interchange (U. C. Berkeley, 2017) for verification of species whose taxonomy may have changed since its publication.

The wetland indicator status of plant species for this investigation was based on the *Western Mountains, Valleys, and Coast 2016 Regional Wetland Plant List* (USACE, 2016). Synonyms were checked for species that did not appear on the USACE wetland plant list. Plant species were classified as:

- ***Obligate (OBL)***—almost always occurs in wetlands
- ***Facultative-wet (FACW)***—usually occurs in wetlands, but may occur in non-wetlands
- ***Facultative (FAC)***—occurs in wetlands and non-wetlands
- ***Facultative-upland (FACU)***—usually occurs in non-wetlands, but may occur in wetlands
- ***Upland (UPL)***—almost never occurs in wetlands
- ***Not listed (NL)***—scored as an upland plant and calculated as such on wetland determination forms

The 50/20 method¹ was applied to each stratum to determine the dominant plant species and to satisfy the hydrophytic vegetation criteria. If either hydric soils or wetland hydrology were present, the prevalence index² was applied. The occurrence and type of plant cover determine whether jurisdictional areas are identified as satisfying the vegetation criteria of a wetland or other waters. Those sites with little or no hydrophytic plant cover, or other sites not capable of supporting hydrophytic plant communities in normal circumstances, are identified as other waters, provided they have an ordinary high water mark (OHWM).

-
1. The 50/20 rule: for each stratum of the plant community, dominant species are the most abundant species that (when ranked in descending order of abundance and cumulatively totaled) immediately exceed 50% of total dominance measure for the stratum, plus any additional species that individually comprise 20% or more of the total dominance measure for the stratum (USACE, 2010).
 2. The prevalence index is a weighted-average wetland indicator status of all plant species in the sampling plot or other sampling unit, where each indicator status category is given a numeric code (OBL = 1, FACW = 2, FAC = 3, FACU = 4, and UPL = 5) and weighting is by abundance (absolute percent cover).

7.2 Soils Methodology

Soils were field-verified for the presence or absence of hydric conditions. All TPs were dug to a minimum depth of 20 inches, and the thickness of each soil horizon was measured. The Munsell Soil Color Chart (Kollmorgen Instruments Corporation, 1998) was referenced to determine the colors of the moist soil matrix and redoximorphic (redox) features (if present). Soils were closely inspected for hydric soil indicators, as defined by the NRCS "Field Indicators of Hydric Soils in the United States" (Version 7.0; USDA, 2010).

7.3 Hydrology Methodology

The presence (or lack) of wetland hydrology indicators was determined by direct observation of surface water, groundwater, or shallow soil saturation during the field investigation. In some cases, hydrology determinations were sought based on hydrology indicators (for example, drainage patterns, geomorphic placement, and water-stained leaves) rather than actual direct evidence from saturation or inundation itself. Additionally, observations were sought to indicate if the site is subject to flooding or standing water. Potential indicators would include water marks, drift deposits, sediment deposits, alpha, alpha-dipyridyl, and similar features. Indicators of extended period saturation would include oxidized rhizospheres surrounding living roots or the presence of reduced iron or sulfur in the soil profile. A site location must contain at least one primary indicator or two secondary indicators to have the hydrology parameter.

Alpha, alpha-dipyridyl was not used due to the above-average rainfall indicated by the WETS rainfall data (Table 1), the occurrence of staining on soil peds was not used as a primary hydrology indicator (Presence of Reduced Iron: C4).

7.4 Ordinary High Water Mark Methodology

For purposes of Section 404 of the CWA, the lateral limits of jurisdiction over non-tidal water bodies in the absence of adjacent wetlands extend to the OHWM. When adjacent wetlands are present, CWA jurisdiction extends beyond the OHWM to the limits of the adjacent wetlands. For purposes of Sections 9 and 10 of the Rivers and Harbors Act of 1899, the lateral extent of federal jurisdiction, which is limited to the traditional navigable waters of the United States, extends to the OHWM, whether or not adjacent wetlands extend landward of the OHWM (USACE, 2014).

USACE regulations define the term OHWM for the purposes of the CWA lateral jurisdiction as follows:

The term "ordinary high water mark" means that line on the shore established by the fluctuations of water and indicated by physical characteristics such as a clear, natural line impressed on the bank, shelving, changes in the character of soil, destruction of terrestrial vegetation, the presence of litter and debris, or other appropriate means that consider the characteristics of the surrounding areas at 33 CFR 328.3(e).

The OHWM in non-perennial streams corresponds with the boundaries of the active channel, which are typically expressed by some combination of three primary indicators: a topographic break in slope, change in sediment characteristics, and change in vegetation characteristics (USACE,

2014). The following supporting features should be considered when making an OHWM determination, to the extent that they can be identified and are deemed reasonably reliable (USACE, 2014):

- Drift/wrack
- Erosion/scour
- Bank undercutting
- Root exposure
- Point bars
- Water staining
- Litter water staining
- removal
- Silt deposits
- Shelving
- Headcut/knickpoint
- Macroinvertebrates

No streams or drainages passed through the study area or area of potential effects and no OHWM was observed.

8.0 Discussion and Results

Field investigations were conducted on March 23, and 24, 2017. Six TPs were excavated to characterize the area and record information for vegetation, soils, and hydrology. Once the relationship was established between hydric soils, vegetation, and hydrology in a portion of the study area, changes in hydrology and vegetation were used along with exploratory soil probing to delineate the boundaries of the wetland.

Locations of TPs are shown on Figure 2. Photos of the study area are shown in Appendix B. In the following sections, the TPs are individually discussed, describing the physical features and considerations of the site, followed by a Data section that summarizes information from the completed "Wetland Determination Data Forms" located in Appendix D.

8.1 TP1 Test Site

8.1.1 Discussion

TP1 is located in the northeastern portion of the study area (Figure 2), and was investigated on March 23, following recent rains during an abnormally wet rainy season. This area is representative a large depression alongside Vance Avenue that supports a number of native species and an isolated native vegetation community. TP1 was excavated within the Vance Avenue right of way on the eastern edge of the depression within an area gently sloping (1-2 percent slope) toward the center of the depression. The TP was excavated on the edge of dune willow and California wax myrtle canopy, at the edge of wetland conditions, and near the beginning of industrial asphalt (See Figure 2 and Photos B1, B2, B3 and B4).

8.1.2 Data

TP1 met two wetland parameters of hydrophytic vegetation and hydric soils. The vegetation parameter was met due to dominance of the area by slough sedge (*Carex obnupta* [OBL]) with 18 percent cover and velvet grass [FAC] with 19 percent cover in the herb stratum and coast willow [FACW] with 42 percent cover and California wax myrtle [FAC] with 13 percent cover in the tree stratum. Lesser dominants included California blackberry [FACU] with 3 percent cover, large quaking grass with 20 percent cover and European beach grass (*Ammophila arenaria* [FACU]) with 5

percent cover. Thirty eight percent of the area within TP1 was bare ground, a result of leaf litter, the nearby road base and a fire hose box. Hydric soils were present as evidenced by the presence of the black histic (A3) indicator. The hydrology parameter was not met at this site due to a lack of wetland hydrology indicators, even following abnormally high recent and seasonal rainfall amounts. Soils were sandy at this location, and well drained. Hydric soils may be a remnant from previous conditions, or a reflection of stormwater flows off of the expanse of asphalt, although a lack of flow patterns suggests this might not be the case.

8.2 TP2 Test Site

8.2.1 Discussion

TP2 is located in the northeastern portion of the study area (Figure 2), approximately 130 feet northwest of TP1, on the opposite edge of the same isolated geomorphic depression. TP2 was excavated on March 23, 2017 following recent rains during an abnormally wet rainy season. TP2 is representative of the northwestern side of the geomorphic depression. The area appears to be relatively undisturbed as evidenced by a higher percentage of native species in spite of its being surrounded by former industrial development. Standing water and a fully closed canopy of coast willow and California wax myrtle indicate the undisturbed nature of the location represented by TP2. The wetland area may be remnants of a former deflation basin that was left relatively undisturbed during the development of the surrounding area (See Figure 2 and Photos B1, B2 and B4).

8.2.2 Data

TP2 had all three wetland parameters present. The vegetation parameter was met due to a dominance of the area surrounding TP2 by slough sedge [OBL] with 19 percent cover in the herb stratum, Himalayan blackberry [FAC] with 5 percent cover in the shrub stratum, and coast willow [FACW] with 70 percent cover and California wax myrtle with 18 percent cover in the tree stratum. Lesser dominants include California blackberry with 1 percent cover and English ivy (*Hedera helix* [FACU]) with 1 percent cover. Eighty-one percent of the area within TP2 was bare ground, a result of pooled water at the time of the survey, deep leaf litter and shade under the California wax myrtle and coast willow canopy. Hydric soils were present as evidenced by the histic epipedon indicator (A2) from 0-12 inches, which is a highly organic soil that forms under saturated conditions. Wetland hydrology was evident within the location surrounding TP2 with numerous wetland hydrology indicators. Primary indicators observed at this location included saturation (A3), high water table (A2), surface water (A1), water marks (B1), and aquatic invertebrates (B13). Secondary indicators included water stained leaves (B9) and a geomorphic position (D2).

8.3 TP3 Test Site

8.3.1 Discussion

TP3 is located in the northwestern portion of the study area (Figure 2), and was investigated on March 23, 2017, following recent rains during an abnormally wet rainy season. TP3 is representative of a large, highly manipulated area in the northwestern section of the project area. The area was at one point the location of a log deck, and is covered in very compacted gravels. On-going manipulation and disturbance within this area is evident, with exposed soils, tire-tracks and

heavy equipment work. Vegetation density varies across the elevated former log deck, with more disturbed and compacted areas supporting very little plant growth. Water was seen ponding in the area as a result of somewhat recent heavy equipment work, including tire tracks and scalping, and recent rainfall within the previous week. The area was mostly level with 0-1 percent slopes (See Figure 2 and Photo B6).

8.3.2 Data

TP3 did not meet any wetland parameters; however several hydrology indicators were observed that falsely indicate wetland hydrology. The vegetation parameter was not met due to dominance of the area by upland indicator species. This included small fescue [NL] with 39 percent cover and large quaking grass [NL] with 20 percent cover. Lesser dominants included creeping bentgrass [FAC] with 4 percent cover, birds-foot trefoil [FAC] with 3 percent cover, among others. Thirty one (31) percent of the area surrounding TP3 was bare soil. This was a result of compacted gravel and recent scalping of the area by heavy equipment. No hydric soil indicators were present, with soils consisting of very compacted gravel over well drained sand. Several wetland hydrology indicators were observed at this location that gave false positive wetland hydrology. Saturation (A3) was observed, however no water table or surface water was present. Saturation was most likely due to recent rainfall, including precipitation the day prior to the field work. Well drained sandy soils and elevation prevent water from pooling. Additional hydrology parameters observed included a sparsely vegetated concave surface (B8) and geomorphic depression (D2). Both of these indicators observed were a direct result of recent heavy equipment work. The sparse vegetation was a result of scalping of the surface the preceding year, which also created the geomorphic depression. The area was investigated to ensure that no wetland areas were overlooked during the wetland delineation, however, TP3 is not considered to meet the hydrology parameter.

8.4 TP4 Test Site

8.4.1 Discussion

TP4 is located in the northern portion of the study area near the recycling facility (Figure 2), and was investigated on March 23, 2017, following recent rains during an abnormally wet rainy season. TP4 is representative of the a geomorphic depression with a DI in the low portion of the swale indicating that this area was likely excavated as a drainage during industrial development. Vegetation was less manipulated than the surrounding elevated areas, with a developed shrub layer, and an isolated Sitka spruce (*Picea sitchensis*). TP4 was excavated within the lowest elevation of the swale, away from the DI in order to investigate the wettest possible location of this swale (See Figure 2).

8.4.2 Data

No wetland indicators were present at TP4. The vegetation parameter was not met due to a dominance of the area surrounding TP4 by upland shrubs. The shrub stratum was dominated by coyote brush [NL], and California blackberry [FACU] with 20 and 13 percent cover respectively. The herb stratum was dominated by the wetland indicator species canary reedgrass (*Phalaris arundinacea* [FACW]) with 30 percent cover, with lesser dominance by the upland indicator species sword fern (*Polystichum munitum* [FACU]) and cutleaf geranium [NL]. Tree stratum was present at this location, provided by Sitka spruce [FAC] with 10 percent cover. Sixty-eight (68) percent of the area around TP4 was bare ground, a result of shading and heavy duff from the shrub and tree

stratums. No hydric soil indicators were present with soils composed of a well draining loam above well drained sand. The two primary wetland hydrology indicators of a high water table (A2), and Saturation (A3) were observed at this location, however, the lack of hydric soils, and lack of dominance of the area by hydrophytic vegetation suggest that these indicators are a result of recent rainfall and abnormally high rainfall totals for the year, rather than wetland hydrology. The nearby DI prevents water from pooling in the area, while the lack of connectivity between the swale and other drainages prevents water from flowing into this area. Due to the lack of additional wetland hydrology indicators, and a lack of additional wetland parameters met at this site, it is determined the area surrounding TP4 does not meet the wetland hydrology parameter and is not considered a wetland.

8.5 TP5 Test Site

8.5.1 Discussion

TP5 is located in the middle western portion of the study area between Vance Avenue and the railroad right of way (Figure 2), and was investigated on March 24, 2017, following recent rains during an abnormally wet rainy season. TP5 is representative of a drainage way between Vance Avenue and the Railbed. The drainage flows through a culvert under the railroad and into a willow dominated wetland to the west of the project area. The area is characterized by non-native grassland reflecting the disturbed nature of the site, and regular disturbance within this area. Slopes ranged between 2 and 3 percent within the area immediately surrounding TP5 (See Figure 2 and Photo B7).

8.5.2 Data

TP5 met both the hydric soil and wetland hydrology parameters, however hydrophytic vegetation was not dominant within the area surrounding TP5. The vegetation parameter was not met due to a dominance of the area surrounding TP 5 by large quaking grass [NL] and sweet vernal grass [FACU] with 18 and 14 percent cover respectively. Additional dominance by the wetland indicator species, velvet grass [FAC] with 15 percent cover was observed. Lesser dominants included birds foot trefoil [FAC], beach strawberry (*Fragaria chiloensis* [FACU]), cutleaf plantain (*Plantago coronopus* [FACU]), and creeping bentgrass [FAC]. Thirty-four (34) percent of the area around TP5 was bare ground, a result of pooled water and poor soil conditions associated with disturbance and previous development. Hydric soils were present as indicated by the hydric soil indicators of sandy redox (S5) and a redox dark surface (F6). Soils were sandy with a 5 inch upper horizon with a significant percentage of organic matter. The presence of sandy redox and a redox dark surface indicates pooling at this site for large portions of the year and persistent wet conditions at this location. Wetland hydrology was observed at this location as evidenced by the wetland hydrology primary indicators of surface water (A1) within 2 feet of the pit, a high water table (A2), saturation (A3), watermarks (B1), a sparsely vegetated concave surface (B8), and aquatic invertebrates (B13). Secondary wetland hydrology indicators observed included water-stained leaves, drainage patterns and a geomorphic position between Vance Avenue and the railroad. The lack of hydrophytic vegetation indicates the disturbed nature of the site rather than a lack of wetland conditions.

8.6 TP6 Test Site

8.6.1 Discussion

TP6 is located in the southern portion of the study area to the west of the railroad tracks (Figure 2), and was investigated on March 24, 2017, following recent rains during an abnormally wet rainy season. TP6 is representative of the edge of the wetland to the west of the project area which receives the drainage from the wetland area represented by TP5. The railroad bed represents an abrupt edge to the wetland; however conditions were investigated to the west of the tracks to ascertain wetlands adjacent to the area of potential effects, and to analyze potential setback requirements. The area at TP6 was not as manipulated as TP5, although conditions were similar. TP6 represents the edge of industrial development and area of natural dune habitat between the railroad and New Navy Base Road. The area was mostly flat with a 0-1% slope preventing water from flowing quickly out of the area (See Figure 2 and Photo B7).

8.6.2 Data

Conditions at TP6 were similar to those found at TP5. TP6 met both the hydric soil and wetland hydrology parameters, however hydrophytic vegetation was not dominant within the area surrounding TP6. The vegetation parameter was not met due to co-dominance of the area surrounding TP6 by the wetland indicator species, dune rush (*Juncus lescurii* [FACW]) with 30 percent cover, and the upland indicator species large quaking grass [NL], with 28 percent cover. Lesser dominants include small fescue [NL], velvet grass [FAC], European beach grass [FACU] and dune knotweed (*Polygonum paronychia* [NL]), among others. Only 14 percent of the area around TP6 was bare ground. This was a result of scattered railroad bed gravel, juvenile large quaking grass and grass thatch. Hydric soils were present as evidenced by a reduced matrix observed in the second horizon, as well as the hydric soil indicators of sandy redox (S5), and a redox dark surface (F6). Soils were sandy from the top horizon down to 24 inches. Much less organic material was observed in the upper horizon at TP6 than was observed at TP5. The presence of a reduced matrix, sandy redox and a redox dark surface indicates pooling at this site for portions of the year and persistent wet conditions at this location. Wetland hydrology was observed at this location as evidenced by the wetland hydrology primary indicators of a high water table (A2), saturation (A3), and oxidized rhizospheres along living roots (C3). The secondary wetland hydrology indicator observed included a geomorphic position west of the railroad. The lack of hydrophytic vegetation dominance, and the heavy dominance of the site by the FACW dune rush, indicates the disturbed nature of the site rather than a lack of wetland conditions.

8.7 Ordinary High Water Mark (OHWM)

No streams or drainages passed through the study area or area of potential effects and no OHWM was observed.

8.8 National Wetlands Inventory (NWI)

The USFWS NWI website (Appendix A) shows freshwater emergent wetland (PEM1C) and excavated freshwater pond (PAB4Hx) NWI designation in the study area. While freshwater emergent wetland was found within the study area, the NWI mapping was found to be inaccurate during the site-specific analysis. Many areas designated as wetland by the NWI mapping were

found not to exhibit wetland parameters, primarily the area to the west and north of the recycling facility. The NWI map does reflect wetland conditions to the west of the project area within the southern portion of the project area. The wetland area represented by TPs 1 and 2 was not depicted on the NWI map, however wetland conditions were present. The area depicted as excavated freshwater pond does reflect conditions on the ground. The NWI map is a good tool for estimating wetland location, type, and extent for reconnaissance purposes, but must be confirmed by on the ground study and delineation. It is stated within the data limitation, exclusions and precautions page that the data contained within the NWI is to be used for reconnaissance level information of wetlands, and a margin of error is inherent with the use of aerial imagery in wetland determination (NWI Data limitations, Exclusions, and Precautions 2017).

9.0 Conclusions

The site investigation occurred during an above-normal rainfall season during the spring of 2017. Following the USACE wetland parameter approach in the coastal zone, where only one wetland parameter is needed for an area to be considered wetland, TP1, TP2, TP5, and TP6 meet one or more of the three wetland parameters of hydrophytic vegetation, hydric soils, and wetland hydrology indicators necessary to place them within wetland boundaries (Figure 2; Table 2).

These pits represent three wetland areas delineated within the project area, and area of potential effects. The first wetland area, represented by TP1 and TP2 is approximately square feet and represents freshwater emergent wetland, within a relatively undisturbed isolated basin. The wetland within this location has a well developed canopy composed of dune willow and California wax myrtle, with a primarily native understory and shrub layer. The area represented by TP1 and TP2 represents valuable wetland habitat surrounded by heavily manipulated industrial development. It is recommended that this hollow be avoided during the project with an appropriate buffer to avoid potential impacts to the wetland habitat at this location.

The second wetland area is represented by TP5 and TP6. TP5 represents a wetland area between Vance Avenue and the railroad tracks that is hydrologically connected to the wetland represented by TP6 through a culvert under the rail bed. Conditions within the wetland at TP5 and TP6 are disturbed, as evidenced by an overwhelming dominance of the area by non-native species and invasive grass species. Stormwater from upland paved industrial areas to the east collect within in the depression between Vance Avenue and the railroad after passing through a culvert under Vance Avenue. Hydric soils, pooled water, and other wetland hydrology indicators indicate the edge of wetland due to the invasive vegetation being a poor indicator of wetland extent. It is recommended that the wetland represented by TP5 and TP6 be avoided during construction, however the lack of quality wetland conditions between the railroad and Vance Avenue may warrant reduced setbacks for the duration of the project. Willow dominated wetland beyond the fence line and area of potential effects represents high quality habitat and should be avoided.

The third wetland area observed exists beyond the fence line and area of potential effects, and was not sampled with a test pit due to lack of wetland conditions on the eastern side of the fence. Even though the area was not sampled, the region beyond the fence represents native dune deflation basin wetland and should be avoided during the life of the project. The existing fence and railroad

tracks represent an established boundary that should prevent encroachment into the wetland area just beyond the fence line. Appropriate buffers should be established to minimize impacts to wetland habitat in the area.

The wetlands across the project area and area of potential effects are freshwater emergent wetlands that occur within historic dune deflation basins, or within industrial drainages. The project area has historically been, and continues to be, highly manipulated and in a state of constant disturbance due to past and ongoing industrial use. The establishment of appropriate buffers surrounding wetland habitat is necessary to ensure that wetland conditions are not disturbed and that habitat remains within the mosaic of disturbed industrial land. The Humboldt Bay Area Plan of the Humboldt County Local Coastal Program sets forth appropriate wetland buffers, buffer reductions and development potential within the vicinity of wetlands at this location. See Figure 2 for the extent of wetlands found at each site. Table 2 describes the wetland conditions found at each TP within this project area.

| Test Pit | # Parameters¹ met | Parameters¹ met | Cowardian Type |
|-----------------|-------------------------------------|-----------------------------------|-----------------------------|
| 1 | 2 | Vegetation, Hydric soils | Freshwater, emergent |
| 2 | 3 | All | Freshwater, emergent |
| 3 | 0 | None | None |
| 4 | 0 | None | None |
| 5 | 2 | Hydric soils, Hydrology | Freshwater, emergent |
| 6 | 2 | Hydric soils, Hydrology | Freshwater, emergent |

1. ACOE Wetland parameters of Hydrophytic Vegetation, Hydric Soils and Hydrology

10.0 Limitations

The conclusions in this report represent a “snapshot in time” and it is possible that some species were not present at the time of the fieldwork. This report documents the investigation by using the best professional judgment of SHN’s botanist and soil scientist. The conclusions should be verified by the USACE through receipt of a jurisdictional determination letter.

11.0 References Cited

- Baldwin, B.G., D.H. Goldman, D.J. Keil, R. Patterson, T.J. Rosatti, and D.H. Wilken, editors. (2012). *The Jepson Manual: Vascular Plants of California, second edition*. Berkeley, CA:University of California Press, Berkeley.
- Calflora. (NR). (accessed January 2017). “Calflora” database, accessed at: <http://calflora.org/>.
- California Data Exchange Center. (accessed March 2017). Eureka Woodley Island, CA. Accessed at: <http://cdec.water.ca.gov/cgi-progs/queryMonthly?ERK>.
- California Native Plant Society. (2017). “CNPS Rare Plant Program, Inventory of Rare and Endangered Plants (online edition, v8-02).” Sacramento, CA:CNPS. Accessed March 2017 at: <http://www.rareplants.cnps.org>.

- Consortium of California Herbaria. (NR). (accessed March 2017) "Consortium of California Herbaria" database accessed at: <http://ucjeps.berkeley.edu/consortium/>.
- County of Humboldt. (2017). Humboldt GIS Portal-Planning and Building: Eureka, CA:Humboldt County. Accessed at: <http://gis.co.humboldt.ca.us/Freeance/Client/PublicAccess1/index.html?appconfig=podgis4>.
- Environmental Laboratory. (1987). *Corps of Engineers Wetland Delineation Manual. Technical Report Y-87-1*. Vicksburg, MS:USACE Waterways Experiment Station.
- Google Earth. (May 26, 2016). 40.902744/-124.019677°. Accessed on March 22, 2017. NR: Google Earth.
- Kollmorgen Instruments Corporation. (1998). *Munsell Soil Color Charts*. Baltimore, MD:Macbeth Division of Kollmorgen Instruments Corporation.
- National Oceanic & Atmospheric Administration, National Climatic Data Center. (accessed March 2017). NOAA/NCDC Database, Arcata Eureka Airport, CA US. Accessed at: <https://www.ncdc.noaa.gov/cdo-web/datatools/normals>.
- University of California, Berkeley. (accessed March 2017). "Consortium of California Herbaria." Accessed at <http://ucjeps.berkeley.edu/consortium/>.
- U.S. Army Corps of Engineers. (2010). *Regional Supplement to the Corps of Engineers Wetland Delineation Manual: Western Mountain, Valleys, and Coast Region*, J.S. Wakeley, R.W. Lichvar, and C.V. Noble (eds) ERDC/EL TR-08-03. Vicksburg, MS:USACE Research and Development Center.
- . (2014). *A Guide to Ordinary High Water Mark (OHWM) Delineation for Non-Perennial Streams in the Western Mountains, Valleys, and Coast Region of the United States*, M. K. Mersel and R. W. Lichvar (eds) ERDC/CRREL TR-14-13. Vicksburg, MS:USACE Research and Development Center.
- . (2016). *Western Mountains, Valleys, and Coast: 2016 Regional Wetland Plant List*, Lichvar, R.W., D.L. Banks, W.N. Kirchner, and N.C. Melvin (eds), ERDC/CRREL. Vicksburg, MS:USACE Research and Development Center.
- U.S. Code of Federal Regulations. (NR). "33 CFR 328. Title 33, Navigation and Navigable Waters; Chapter II; Army Corp of Engineers, Dept. of Defense, Part 328, Regulatory Program of the U.S. Army Corps of Engineers." NR:USACE.
- U.S. Department of Agriculture, Natural Resources Conservation Service. (2010). *Field Indicators of Hydric Soils in the United States, Version 7.0*. G.W. Hurt, L.M. Vasilas (eds.). NR: USDA, NRCS in cooperation with the National Technical Committee for Hydric Soils.
- . (2017). WETS Database. Eureka Woodley Island, Eureka, CA. Accessed at: <http://agacis.rcc-acis.org/?fips=06023>.
- . (2017b). Unpublished data provided by NRCS office in Arcata, CA on 1/25/17.
- U.S. Fish and Wildlife Service. (Accessed March 2017). National Wetlands Inventory. Accessed at: <http://www.fws.gov/wetlands/data/mapper.HTML/>.

DRAFT

A









National Wetlands Inventory



U.S. Fish and Wildlife Service
National Wetlands Inventory



March 2, 2017

- | | | |
|--|---|--|
|  Estuarine and Marine Deepwater |  Freshwater Forested/Shrub Wetland |  Other |
|  Estuarine and Marine Wetland |  Freshwater Pond |  Riverine |
|  Freshwater Emergent Wetland |  Lake | |

This map is for general reference only. The US Fish and Wildlife Service is not responsible for the accuracy or currentness of the base data shown on this map. All wetlands related data should be used in accordance with the layer metadata found on the Wetlands Mapper web site.

DRAFT

B

Site Photographs



Photo B1: TP1 and TP2 Area, looking south. Note well developed dune willow and California wax myrtle canopy.



Photo B2: TP1 and TP2 Area, looking west. Note abrupt edge of willow canopy and beginning of disturbed industrial area characterized by non-native herbaceous vegetation.



Photo B3: Soil profile at TP1. Note black histic layer underlain by very loose sand. (Dark color of upper horizon somewhat lost due to direct sun and photo quality).



Photo B4: TP2 Site looking north beneath the canopy (3 parameter). Note pooled water in background (dark region), and dominance of the area by native vegetation.



Photo B5: Region west of the Recycling facility. Note lack of wetland conditions and wetland vegetation. NWI aerial mapping mistook California blackberry thicket for wetland vegetation.



Photo B6: Region northwest of the recycling facility. Note lack of wetland conditions and wetland vegetation. Gorse in foreground extremely invasive, with great potential to invade surrounding land.



Photo B7: Southern study area, looking south. Wetland found along side Vance Avenue and Railroad, in vicinity of willow thicket on the right side of the photo.



Photo B8: Southern terminus of the project area, looking east. Note dominance by upland vegetation, and lack of wetland conditions.

DRAFT

C

Plant List

**Table C-1
Plants Observed at Wetland Pits
RMTII Samoa Effluent Pipeline, Samoa, California**

| Scientific Name | Common Name | Indicator 2016¹ |
|--------------------------------|-----------------------|-----------------------------------|
| <i>Agrostis stolonifera</i> | creeping bentgrass | FAC |
| <i>Ammophila arenaria</i> | European beach grass | FACU |
| <i>Anthoxanthum odoratum</i> | sweet vernal grass | FACU |
| <i>Baccharis pilularis</i> | coyote brush | NL |
| <i>Briza maxima</i> | large quaking grass | NL |
| <i>Cardionema ramosissimum</i> | sand mat | NL |
| <i>Carex obnupta</i> | slough sedge | OBL |
| <i>Festuca microstachys</i> | small fescue | NL |
| <i>Fragaria chiloensis</i> | beach strawberry | FACU |
| <i>Geranium dissectum</i> | cutleaf geranium | NL |
| <i>Hedera helix</i> | English ivy | FACU |
| <i>Holcus lanatus</i> | velvet grass | FAC |
| <i>Juncus lescurii</i> | dune rush | FACW |
| <i>Lotus corniculatus</i> | birds-foot trefoil | FAC |
| <i>Morella californica</i> | California wax-myrtle | FAC |
| <i>Phalaris arundinacea</i> | Canary reedgrass | FACW |
| <i>Picea sitchensis</i> | Sitka spruce | FAC |
| <i>Plantago coronopus</i> | cutleaf plantain | FACU |
| <i>Polygonum paronychia</i> | dune knotweed | NL |
| <i>Polystichum munitum</i> | sword fern | FACU |
| <i>Rubus armeniacus</i> | Himalayan blackberry | FAC |
| <i>Rubus ursinus</i> | California blackberry | FACU |
| <i>Salix hookeriana</i> | dune rush | FACW |
| <i>Vicia sativa</i> | spring vetch | UPL |

1. Indicators are abbreviated as follows:
OBL: Obligate
FACW: Facultative
FAC: Facultative
FACU: Facultative upland
UPL: Upland
NL: Not listed (considered upland)

DRAFT

D

Wetland Determination Data Forms

WETLAND DETERMINATION DATA FORM – Western Mountains, Valleys, and Coast Region

Project/Site: RMT II Samoa Effluent Pipe City/County: Humboldt Sampling Date: 3/23/2017
 Applicant/Owner: HB Harbor District State: CA Sampling Point: TP 9
 Investigator(s): Saler, J.; Potts, S. Section, Township, Range: Sec. 15, 16+17, T5N, R1W, HBM
 Landform (hillslope, terrace, etc.): Sandy Dunes (Ind. fill) Local relief (concave, convex, none): Concave Slope (%): 1-2
 Subregion (LRR): A, MLRA, 4B Lat: 40.813128° Long: -124.190174° Datum: _____
 Soil Map Unit Name: Samoa-clam beach-Dune lands, Industrial fill NWI classification: None
 Are climatic / hydrologic conditions on the site typical for this time of year? Yes _____ No (If no, explain in Remarks.)
 Are Vegetation _____, Soil _____, or Hydrology _____ significantly disturbed? Are "Normal Circumstances" present? Yes No _____
 Are Vegetation _____, Soil _____, or Hydrology _____ naturally problematic? (If needed, explain any answers in Remarks.)

SUMMARY OF FINDINGS – Attach site map showing sampling point locations, transects, important features, etc.

| | | | |
|---|--|---------------------------------------|--|
| Hydrophytic Vegetation Present? | Yes <input checked="" type="checkbox"/> No _____ | Is the Sampled Area within a Wetland? | Yes <input checked="" type="checkbox"/> No _____ |
| Hydric Soil Present? | Yes <input checked="" type="checkbox"/> No _____ | | |
| Wetland Hydrology Present? | Yes _____ No <input checked="" type="checkbox"/> | | |
| Remarks: <u>by red fire hydrant ~170% above normal rainfall</u> | | | |

VEGETATION – Use scientific names of plants.

| Tree Stratum (Plot size: _____) | Absolute % Cover | Dominant Species? | Indicator Status | Dominance Test worksheet: |
|--|------------------|-------------------------------------|--------------------------|--|
| 1. <u>Salix hookeriana</u> | <u>42</u> | <input checked="" type="checkbox"/> | <u>FACW</u> | |
| 2. <u>Morella californica</u> | <u>13</u> | <input checked="" type="checkbox"/> | <u>FAC</u> | Total Number of Dominant Species Across All Strata: <u>6</u> (B) |
| 3. _____ | | | | Percent of Dominant Species That Are OBL, FACW, or FAC: <u>67%</u> (A/B) |
| 4. _____ | | | | |
| | | | <u>55</u> = Total Cover | |
| Sapling/Shrub Stratum (Plot size: _____) | Absolute % Cover | Dominant Species? | Indicator Status | Prevalence Index worksheet: |
| 1. <u>Rubus ursinus</u> | <u>3</u> | <input checked="" type="checkbox"/> | <u>FACU</u> | |
| 2. _____ | | | | OBL species _____ x 1 = _____ |
| 3. _____ | | | | FACW species _____ x 2 = _____ |
| 4. _____ | | | | FAC species _____ x 3 = _____ |
| 5. _____ | | | | FACU species _____ x 4 = _____ |
| | | | <u>3</u> = Total Cover | UPL species _____ x 5 = _____ |
| | | | | Column Totals: _____ (A) _____ (B) |
| | | | | Prevalence Index = B/A = _____ |
| Herb Stratum (Plot size: _____) | Absolute % Cover | Dominant Species? | Indicator Status | Hydrophytic Vegetation Indicators: |
| 1. <u>Carex obnupta</u> | <u>18</u> | <input checked="" type="checkbox"/> | <u>Obl</u> | |
| 2. <u>Briza maxima</u> | <u>20</u> | <input checked="" type="checkbox"/> | <u>NL</u> | <input checked="" type="checkbox"/> 2 - Dominance Test is >50% |
| 3. <u>Malcus lanatus</u> | <u>19</u> | <input checked="" type="checkbox"/> | <u>FAC</u> | ____ 3 - Prevalence Index is ≤3.0 ¹ |
| 4. <u>Ammophila arenaria</u> | <u>5</u> | <input checked="" type="checkbox"/> | <u>FACU</u> | ____ 4 - Morphological Adaptations ¹ (Provide supporting data in Remarks or on a separate sheet) |
| 5. _____ | | | | ____ 5 - Wetland Non-Vascular Plants ¹ |
| 6. _____ | | | | ____ Problematic Hydrophytic Vegetation ¹ (Explain) |
| 7. _____ | | | | ¹ Indicators of hydric soil and wetland hydrology must be present, unless disturbed or problematic. |
| 8. _____ | | | | |
| 9. _____ | | | | |
| 10. _____ | | | | |
| 11. _____ | | | | |
| | | | <u>62</u> = Total Cover | |
| | | | <u>31</u> <u>12.4</u> | |
| Woody Vine Stratum (Plot size: _____) | Absolute % Cover | Dominant Species? | Indicator Status | Hydrophytic Vegetation Present? |
| 1. _____ | | | | |
| 2. _____ | | | | |
| | | | | |
| | | | <u>38%</u> | |
| | | | | |
| Remarks: | | | | |

SOIL

Sampling Point: TP 1

Profile Description: (Describe to the depth needed to document the indicator or confirm the absence of indicators.)

| Depth (inches) | Matrix | | Redox Features | | | | Texture | Remarks |
|----------------|---------------|-----|----------------|---|-------------------|------------------|---------|-------------------------------|
| | Color (moist) | % | Color (moist) | % | Type ¹ | Loc ² | | |
| 0-10 | 10YR 2/1 | 100 | | | | | M Sand | Jet Black Muck w/ sand grains |
| 10-24+ | 10YR 4/2 | 100 | | | | | Sand | very loose |
| | | | | | | | | |
| | | | | | | | | |
| | | | | | | | | |
| | | | | | | | | |
| | | | | | | | | |

¹Type: C=Concentration, D=Depletion, RM=Reduced Matrix, CS=Covered or Coated Sand Grains. ²Location: PL=Pore Lining, M=Matrix.

| Hydric Soil Indicators: (Applicable to all LRRs, unless otherwise noted.) | | Indicators for Problematic Hydric Soils ³ : |
|---|---|---|
| <input type="checkbox"/> Histosol (A1) | <input type="checkbox"/> Sandy Redox (S5) | <input type="checkbox"/> 2 cm Muck (A10) |
| <input type="checkbox"/> Histic Epipedon (A2) | <input type="checkbox"/> Stripped Matrix (S6) | <input type="checkbox"/> Red Parent Material (TF2) |
| <input checked="" type="checkbox"/> Black Histic (A3) | <input type="checkbox"/> Loamy Mucky Mineral (F1) (except MLRA 1) | <input type="checkbox"/> Very Shallow Dark Surface (TF12) |
| <input type="checkbox"/> Hydrogen Sulfide (A4) | <input type="checkbox"/> Loamy Gleyed Matrix (F2) | <input type="checkbox"/> Other (Explain in Remarks) |
| <input type="checkbox"/> Depleted Below Dark Surface (A11) | <input type="checkbox"/> Depleted Matrix (F3) | ³ Indicators of hydrophytic vegetation and wetland hydrology must be present, unless disturbed or problematic. |
| <input type="checkbox"/> Thick Dark Surface (A12) | <input type="checkbox"/> Redox Dark Surface (F6) | |
| <input type="checkbox"/> Sandy Mucky Mineral (S1) | <input type="checkbox"/> Depleted Dark Surface (F7) | |
| <input type="checkbox"/> Sandy Gleyed Matrix (S4) | <input type="checkbox"/> Redox Depressions (F8) | |
| | | |

Restrictive Layer (if present):
 Type: _____
 Depth (inches): _____

Hydric Soil Present? Yes No

Remarks:

HYDROLOGY

| Wetland Hydrology Indicators: | |
|--|---|
| Primary Indicators (minimum of one required; check all that apply) | Secondary Indicators (2 or more required) |
| <input type="checkbox"/> Surface Water (A1) | <input type="checkbox"/> Water-Stained Leaves (B9) (except MLRA 1, 2, 4A, and 4B) |
| <input type="checkbox"/> High Water Table (A2) | <input type="checkbox"/> Water-Stained Leaves (B9) (MLRA 1, 2, 4A, and 4B) |
| <input type="checkbox"/> Saturation (A3) | <input type="checkbox"/> Salt Crust (B11) |
| <input type="checkbox"/> Water Marks (B1) | <input type="checkbox"/> Drainage Patterns (B10) |
| <input type="checkbox"/> Sediment Deposits (B2) | <input type="checkbox"/> Aquatic Invertebrates (B13) |
| <input type="checkbox"/> Drift Deposits (B3) | <input type="checkbox"/> Dry-Season Water Table (C2) |
| <input type="checkbox"/> Algal Mat or Crust (B4) | <input type="checkbox"/> Hydrogen Sulfide Odor (C1) |
| <input type="checkbox"/> Iron Deposits (B5) | <input type="checkbox"/> Oxidized Rhizospheres along Living Roots (C3) |
| <input type="checkbox"/> Surface Soil Cracks (B6) | <input type="checkbox"/> Presence of Reduced Iron (C4) |
| <input type="checkbox"/> Inundation Visible on Aerial Imagery (B7) | <input type="checkbox"/> Recent Iron Reduction in Tilled Soils (C6) |
| <input type="checkbox"/> Sparsely Vegetated Concave Surface (B8) | <input type="checkbox"/> Stunted or Stressed Plants (D1) (LRR A) |
| | <input type="checkbox"/> Other (Explain in Remarks) |
| | <input type="checkbox"/> FAC-Neutral Test (D5) |
| | <input type="checkbox"/> Raised Ant Mounds (D6) (LRR A) |
| | <input type="checkbox"/> Frost-Heave Hummocks (D7) |

Field Observations:

Surface Water Present? Yes No Depth (inches): _____

Water Table Present? Yes No Depth (inches): _____

Saturation Present? (includes capillary fringe) Yes No Depth (inches): _____

Wetland Hydrology Present? Yes No

Describe Recorded Data (stream gauge, monitoring well, aerial photos, previous inspections), if available:

Remarks:

WETLAND DETERMINATION DATA FORM – Western Mountains, Valleys, and Coast Region

Project/Site: RMT II Samoa Effluent Pipeline City/County: Humboldt Sampling Date: 3/23/2017
 Applicant/Owner: Humboldt Bay Harbor District State: CA Sampling Point: TP 2
 Investigator(s): Sam Polly, Joseph Saker Section, Township, Range: Sec. 15, 16+17, T5N, R1W, HBM
 Landform (hillslope, terrace, etc.): Depletion Basin Local relief (concave, convex, none): Concave Slope (%): 3-45 (steep into bed)
 Subregion (LRR): A, MLRA, 4B Lat: 40.813128° Long: -124.190174° Datum: _____
 Soil Map Unit Name: Samoa-clam beach-dune lands, Industrial fill NWI classification: None

Are climatic / hydrologic conditions on the site typical for this time of year? Yes _____ No X (If no, explain in Remarks.)
 Are Vegetation _____, Soil _____, or Hydrology _____ significantly disturbed? Are "Normal Circumstances" present? Yes X No _____
 Are Vegetation _____, Soil _____, or Hydrology _____ naturally problematic? (If needed, explain any answers in Remarks.)

SUMMARY OF FINDINGS – Attach site map showing sampling point locations, transects, important features, etc.

| | | |
|---|-----------------------|---|
| Hydrophytic Vegetation Present? | Yes <u>X</u> No _____ | Is the Sampled Area within a Wetland? Yes <u>X</u> No _____ |
| Hydric Soil Present? | Yes <u>X</u> No _____ | |
| Wetland Hydrology Present? | Yes <u>X</u> No _____ | |
| Remarks: <u>~170% above normal rainfall for the season</u> | | |

VEGETATION – Use scientific names of plants.

| Tree Stratum (Plot size: _____) | Absolute % Cover | Dominant Species? | Indicator Status | Dominance Test worksheet: Number of Dominant Species That Are OBL, FACW, or FAC: <u>4</u> (A) Total Number of Dominant Species Across All Strata: <u>5</u> (B) Percent of Dominant Species That Are OBL, FACW, or FAC: <u>80%</u> (A/B) |
|--|------------------|-------------------|--------------------------|--|
| 1. <u>Salix hatteriana</u> | <u>70</u> | <u>✓</u> | <u>FACW</u> | |
| 2. <u>Mullella californica</u> | <u>18</u> | <u>✓</u> | <u>FAC</u> | |
| 3. _____ | | | | |
| 4. _____ | | | | |
| | <u>88</u> | = Total Cover | <u>44</u> <u>11.6</u> | |
| Sapling/Shrub Stratum (Plot size: _____) | Absolute % Cover | Dominant Species? | Indicator Status | Prevalence Index worksheet: Total % Cover of: _____ Multiply by: _____ OBL species _____ x 1 = _____ FACW species _____ x 2 = _____ FAC species _____ x 3 = _____ FACU species _____ x 4 = _____ UPL species _____ x 5 = _____ Column Totals: _____ (A) _____ (B) Prevalence Index = B/A = _____ |
| 1. <u>Rubus ursinus</u> | <u>1</u> | <u>✓</u> | <u>FACU</u> | |
| 2. <u>Rubus armeniacus</u> | <u>5</u> | <u>✓</u> | <u>FAC</u> | |
| 3. _____ | | | | |
| 4. _____ | | | | |
| 5. _____ | | | | |
| | <u>6</u> | = Total Cover | <u>3</u> <u>1.2</u> | |
| Herb Stratum (Plot size: _____) | Absolute % Cover | Dominant Species? | Indicator Status | Hydrophytic Vegetation Indicators: 1 - Rapid Test for Hydrophytic Vegetation <u>X</u> 2 - Dominance Test is >50% ____ 3 - Prevalence Index is ≤3.0 ¹ ____ 4 - Morphological Adaptations ¹ (Provide supporting data in Remarks or on a separate sheet) ____ 5 - Wetland Non-Vascular Plants ¹ ____ Problematic Hydrophytic Vegetation ¹ (Explain) ¹ Indicators of hydric soil and wetland hydrology must be present, unless disturbed or problematic. |
| 1. <u>Carex obnupta</u> | <u>19</u> | <u>✓</u> | <u>Obl</u> | |
| 2. _____ | | | | |
| 3. _____ | | | | |
| 4. _____ | | | | |
| 5. _____ | | | | |
| 6. _____ | | | | |
| 7. _____ | | | | |
| 8. _____ | | | | |
| 9. _____ | | | | |
| 10. _____ | | | | |
| 11. _____ | | | | |
| | <u>19</u> | = Total Cover | | |
| Woody Vine Stratum (Plot size: _____) | Absolute % Cover | Dominant Species? | Indicator Status | Hydrophytic Vegetation Present? Yes <u>X</u> No _____ |
| 1. <u>Hedera helix</u> | <u>1</u> | <u>✓</u> | <u>FACU</u> | |
| 2. _____ | | | | |
| | <u>1</u> | = Total Cover | | |
| % Bare Ground in Herb Stratum <u>81%</u> | | | | |
| Remarks: <u>- Bare ground includes open water.</u> | | | | |

SOIL

Sampling Point: TP2

Profile Description: (Describe to the depth needed to document the indicator or confirm the absence of indicators.)

| Depth (inches) | Matrix | | Redox Features | | | | Texture | Remarks |
|----------------|---------------|-----|----------------|---|-------------------|------------------|---------|--------------------------|
| | Color (moist) | % | Color (moist) | % | Type ¹ | Loc ² | | |
| 0-12 | 10YR 2/1 | 100 | | | | | Muck | Small percentage of sand |
| 12-24+ | 10Y 2.5/1 | 100 | | | | | Sand | |
| | | | | | | | | |
| | | | | | | | | |
| | | | | | | | | |
| | | | | | | | | |
| | | | | | | | | |
| | | | | | | | | |

¹Type: C=Concentration, D=Depletion, RM=Reduced Matrix, CS=Covered or Coated Sand Grains. ²Location: PL=Pore Lining, M=Matrix.

Hydric Soil Indicators: (Applicable to all LRRs, unless otherwise noted.)

| | | |
|--|---|---|
| <input checked="" type="checkbox"/> Histosol (A1) | <input type="checkbox"/> Sandy Redox (S5) | <input type="checkbox"/> 2 cm Muck (A10) |
| <input checked="" type="checkbox"/> Histic Épipedon (A2) | <input type="checkbox"/> Stripped Matrix (S6) | <input type="checkbox"/> Red Parent Material (TF2) |
| <input type="checkbox"/> Black Histic (A3) | <input type="checkbox"/> Loamy Mucky Mineral (F1) (except MLRA 1) | <input type="checkbox"/> Very Shallow Dark Surface (TF12) |
| <input type="checkbox"/> Hydrogen Sulfide (A4) | <input type="checkbox"/> Loamy Gleyed Matrix (F2) | <input type="checkbox"/> Other (Explain in Remarks) |
| <input type="checkbox"/> Depleted Below Dark Surface (A11) | <input type="checkbox"/> Depleted Matrix (F3) | ³ Indicators of hydrophytic vegetation and wetland hydrology must be present, unless disturbed or problematic. |
| <input type="checkbox"/> Thick Dark Surface (A12) | <input type="checkbox"/> Redox Dark Surface (F6) | |
| <input type="checkbox"/> Sandy Mucky Mineral (S1) | <input type="checkbox"/> Depleted Dark Surface (F7) | |
| <input type="checkbox"/> Sandy Gleyed Matrix (S4) | <input type="checkbox"/> Redox Depressions (F8) | |
| | | |

Restrictive Layer (if present):

Type: _____

Depth (inches): _____

Hydric Soil Present? Yes No

Remarks:

HYDROLOGY

Wetland Hydrology Indicators:

Primary Indicators (minimum of one required; check all that apply)

| | | |
|--|---|---|
| <input checked="" type="checkbox"/> Surface Water (A1) | <input type="checkbox"/> Water-Stained Leaves (B9) (except MLRA 1, 2, 4A, and 4B) | <u>Secondary Indicators (2 or more required)</u> |
| <input checked="" type="checkbox"/> High Water Table (A2) | <input type="checkbox"/> Salt Crust (B11) | <input checked="" type="checkbox"/> Water-Stained Leaves (B9) (MLRA 1, 2, 4A, and 4B) |
| <input checked="" type="checkbox"/> Saturation (A3) | <input checked="" type="checkbox"/> Aquatic Invertebrates (B13) | <input type="checkbox"/> Drainage Patterns (B10) |
| <input checked="" type="checkbox"/> Water Marks (B1) | <input type="checkbox"/> Hydrogen Sulfide Odor (C1) | <input type="checkbox"/> Dry-Season Water Table (C2) |
| <input type="checkbox"/> Sediment Deposits (B2) | <input type="checkbox"/> Oxidized Rhizospheres along Living Roots (C3) | <input type="checkbox"/> Saturation Visible on Aerial Imagery (C9) |
| <input type="checkbox"/> Drift Deposits (B3) | <input type="checkbox"/> Presence of Reduced Iron (C4) | <input checked="" type="checkbox"/> Geomorphic Position (D2) |
| <input type="checkbox"/> Algal Mat or Crust (B4) | <input type="checkbox"/> Recent Iron Reduction in Tilled Soils (C6) | <input type="checkbox"/> Shallow Aquitard (D3) |
| <input type="checkbox"/> Iron Deposits (B5) | <input type="checkbox"/> Stunted or Stressed Plants (D1) (LRR A) | <input type="checkbox"/> FAC-Neutral Test (D5) |
| <input type="checkbox"/> Surface Soil Cracks (B6) | <input type="checkbox"/> Other (Explain in Remarks) | <input type="checkbox"/> Raised Ant Mounds (D6) (LRR A) |
| <input type="checkbox"/> Inundation Visible on Aerial Imagery (B7) | | <input type="checkbox"/> Frost-Heave Hummocks (D7) |
| <input type="checkbox"/> Sparsely Vegetated Concave Surface (B8) | | |

Field Observations:

Surface Water Present? Yes No Depth (inches): Surface

Water Table Present? Yes No Depth (inches): ↓

Saturation Present? (includes capillary fringe) Yes No Depth (inches): ↓

Wetland Hydrology Present? Yes No

Describe Recorded Data (stream gauge, monitoring well, aerial photos, previous inspections), if available:

Remarks:

WETLAND DETERMINATION DATA FORM – Western Mountains, Valleys, and Coast Region

Project/Site: RMT II Samoa Effluent Pipeline City/County: Humboldt Sampling Date: 3/23/2017
 Applicant/Owner: Humboldt Bay Harbor District State: CA Sampling Point: TP3
 Investigator(s): Joseph Siler, Sam Polly Section, Township, Range: Sec. 15, 16+17, T5N, R1W, HBM
 Landform (hillslope, terrace, etc.): Dunes on Ind. fill Local relief (concave, convex, none): Concave Slope (%): 0-1
 Subregion (LRR): A, MLRA 4B Lat: 40.813128° Long: -124.190174° Datum: _____
 Soil Map Unit Name: Samoa-Clanbeach-Dundlands, Industrial fill NWI classification: None
 Are climatic / hydrologic conditions on the site typical for this time of year? Yes _____ No X (If no, explain in Remarks.)
 Are Vegetation X, Soil X, or Hydrology X significantly disturbed? Are "Normal Circumstances" present? Yes _____ No X
 Are Vegetation _____, Soil _____, or Hydrology _____ naturally problematic? (If needed, explain any answers in Remarks.)

SUMMARY OF FINDINGS – Attach site map showing sampling point locations, transects, important features, etc.

| | |
|---|---|
| Hydrophytic Vegetation Present? Yes _____ No <u>X</u> | Is the Sampled Area within a Wetland? Yes _____ No <u>X</u> |
| Hydric Soil Present? <i>see remarks</i> Yes _____ No <u>X</u> | |
| Wetland Hydrology Present? Yes <u>X</u> No _____ | |
| Remarks: <u>~ 170 % above normal rainfall for the season</u> <u>~ Excavated pit within industrial fill</u> | |

VEGETATION – Use scientific names of plants.

| Tree Stratum (Plot size: _____) | Absolute % Cover | Dominant Species? | Indicator Status | Dominance Test worksheet: Number of Dominant Species That Are OBL, FACW, or FAC: _____ (A) Total Number of Dominant Species Across All Strata: _____ (B) Percent of Dominant Species That Are OBL, FACW, or FAC: _____ (A/B) |
|--|------------------|-------------------|------------------|--|
| 1. _____ | | | | |
| 2. _____ | | | | |
| 3. _____ | | | | |
| 4. _____ | | | | |
| = Total Cover | | | | Prevalence Index worksheet: Total % Cover of: _____ Multiply by: OBL species _____ x 1 = _____ FACW species _____ x 2 = _____ FAC species _____ x 3 = _____ FACU species _____ x 4 = _____ UPL species _____ x 5 = _____ Column Totals: _____ (A) _____ (B) Prevalence Index = B/A = _____ |
| Sapling/Shrub Stratum (Plot size: _____) | | | | |
| 1. _____ | | | | |
| 2. _____ | | | | |
| 3. _____ | | | | |
| 4. _____ | | | | |
| 5. _____ | | | | |
| = Total Cover | | | | |
| Herb Stratum (Plot size: _____) | | | | Hydrophytic Vegetation Indicators: ___ 1 - Rapid Test for Hydrophytic Vegetation ___ 2 - Dominance Test is >50% ___ 3 - Prevalence Index is ≤3.0 ¹ ___ 4 - Morphological Adaptations ¹ (Provide supporting data in Remarks or on a separate sheet) ___ 5 - Wetland Non-Vascular Plants ¹ ___ Problematic Hydrophytic Vegetation ¹ (Explain) ¹ Indicators of hydric soil and wetland hydrology must be present, unless disturbed or problematic. |
| 1. <u>Agrostis stolonifera</u> | <u>4</u> | | <u>FAC</u> | |
| 2. <u>Lolium corniculatum</u> | <u>3</u> | | <u>FAC</u> | |
| 3. <u>Holcus lanatus</u> | <u>2</u> | | <u>FAC</u> | |
| 4. <u>Briza maxima</u> | <u>20</u> | <u>✓</u> | <u>NE</u> | |
| 5. <u>Festuca microstachys</u> | <u>39</u> | <u>✓</u> | <u>NE</u> | |
| 6. <u>Vicia sativa</u> | <u>1</u> | | <u>UPL</u> | |
| 7. _____ | | | | |
| 8. _____ | | | | |
| 9. _____ | | | | |
| 10. _____ | | | | |
| 11. _____ | | | | |
| <u>69</u> = Total Cover <u>39.5</u> <u>138</u> | | | | |
| Woody Vine Stratum (Plot size: _____) | | | | Hydrophytic Vegetation Present? Yes _____ No _____ |
| 1. _____ | | | | |
| 2. _____ | | | | |
| = Total Cover | | | | |
| % Bare Ground in Herb Stratum <u>31</u> | | | | |
| Remarks: <u>- Within shallow, excavated depression</u> | | | | |

SOIL

Sampling Point: TP3

Profile Description: (Describe to the depth needed to document the indicator or confirm the absence of indicators.)

| Depth (inches) | Matrix | | Redox Features | | | | Texture | Remarks |
|----------------|---------------|-----|----------------|---|-------------------|------------------|---------|---------------|
| | Color (moist) | % | Color (moist) | % | Type ¹ | Loc ² | | |
| 0-2 | 10YR 2/1 | 100 | | | | | Loam | |
| 2-8 | 10YR 4/1 | 100 | | | | | VCOL | Imported fill |
| 8-24+ | 2.5Y 4/2 | 100 | | | | | Sand | |
| | | | | | | | | |
| | | | | | | | | |
| | | | | | | | | |
| | | | | | | | | |
| | | | | | | | | |

¹Type: C=Concentration, D=Depletion, RM=Reduced Matrix, CS=Covered or Coated Sand Grains. ²Location: PL=Pore Lining, M=Matrix.

Hydric Soil Indicators: (Applicable to all LRRs, unless otherwise noted.)

| | | |
|--|---|---|
| <input type="checkbox"/> Histosol (A1) | <input type="checkbox"/> Sandy Redox (S5) | <input type="checkbox"/> 2 cm Muck (A10) |
| <input type="checkbox"/> Histic Epipedon (A2) | <input type="checkbox"/> Stripped Matrix (S6) | <input type="checkbox"/> Red Parent Material (TF2) |
| <input type="checkbox"/> Black Histic (A3) | <input type="checkbox"/> Loamy Mucky Mineral (F1) (except MLRA 1) | <input type="checkbox"/> Very Shallow Dark Surface (TF12) |
| <input type="checkbox"/> Hydrogen Sulfide (A4) | <input type="checkbox"/> Loamy Gleyed Matrix (F2) | <input type="checkbox"/> Other (Explain in Remarks) |
| <input type="checkbox"/> Depleted Below Dark Surface (A11) | <input type="checkbox"/> Depleted Matrix (F3) | |
| <input type="checkbox"/> Thick Dark Surface (A12) | <input type="checkbox"/> Redox Dark Surface (F6) | |
| <input type="checkbox"/> Sandy Mucky Mineral (S1) | <input type="checkbox"/> Depleted Dark Surface (F7) | |
| <input type="checkbox"/> Sandy Gleyed Matrix (S4) | <input type="checkbox"/> Redox Depressions (F8) | |

Indicators for Problematic Hydric Soils³:

³Indicators of hydrophytic vegetation and wetland hydrology must be present, unless disturbed or problematic.

Restrictive Layer (if present):

Type: _____

Depth (inches): _____

Hydric Soil Present? Yes _____ No

Remarks:
At 8 inches: Thin layer 7.5Y 2.5/3

HYDROLOGY

Wetland Hydrology Indicators:

| | |
|---|--|
| Primary Indicators (minimum of one required; check all that apply) | Secondary Indicators (2 or more required) |
| <input type="checkbox"/> Surface Water (A1) | <input type="checkbox"/> Water-Stained Leaves (B9) (MLRA 1, 2, 4A, and 4B) |
| <input type="checkbox"/> High Water Table (A2) | <input type="checkbox"/> Drainage Patterns (B10) |
| <input checked="" type="checkbox"/> Saturation (A3) | <input type="checkbox"/> Dry-Season Water Table (C2) |
| <input type="checkbox"/> Water Marks (B1) | <input type="checkbox"/> Saturation Visible on Aerial Imagery (C9) |
| <input type="checkbox"/> Sediment Deposits (B2) | <input checked="" type="checkbox"/> Geomorphic Position (D2) |
| <input type="checkbox"/> Drift Deposits (B3) | <input type="checkbox"/> Shallow Aquitard (D3) |
| <input type="checkbox"/> Algal Mat or Crust (B4) | <input type="checkbox"/> FAC-Neutral Test (D5) |
| <input type="checkbox"/> Iron Deposits (B5) | <input type="checkbox"/> Raised Ant Mounds (D6) (LRR A) |
| <input type="checkbox"/> Surface Soil Cracks (B6) | <input type="checkbox"/> Frost-Heave Hummocks (D7) |
| <input type="checkbox"/> Inundation Visible on Aerial Imagery (B7) | |
| <input checked="" type="checkbox"/> Sparsely Vegetated Concave Surface (B8) | |

Field Observations:

Surface Water Present? Yes _____ No Depth (inches): _____

Water Table Present? Yes _____ No Depth (inches): _____

Saturation Present? (includes capillary fringe) Yes No _____ Depth (inches): 2-4 inches

Wetland Hydrology Present? Yes No _____

Describe Recorded Data (stream gauge, monitoring well, aerial photos, previous inspections), if available:

Remarks:
- Hydrology reflects current high rainfall (no water table present)
- Sparsely vegetated surface, potentially a result of recent heavy equipment use
- Geomorphic position a shallow excavated depression

WETLAND DETERMINATION DATA FORM – Western Mountains, Valleys, and Coast Region

Project/Site: RMT II Samoa Effluent Pipeline City/County: Humboldt Sampling Date: 3/23/2017
 Applicant/Owner: Humboldt Bay Harbor District State: CA Sampling Point: TP 4
 Investigator(s): Sam Polly, Joseph Saker Section, Township, Range: Sec. 15, 16+17, T5N, R1W, HBM
 Landform (hillslope, terrace, etc.): Industrial site in Dunes Local relief (concave, convex, none): Concave Slope (%): 0-1
 Subregion (LRR): A MLRA 4B Lat: 40.812757' Long: -124.190930 Datum: _____
 Soil Map Unit Name: Samoa-Clambeach-Dunelands, Industrial fill NWI classification: None
 Are climatic / hydrologic conditions on the site typical for this time of year? Yes _____ No X (If no, explain in Remarks.)
 Are Vegetation _____, Soil _____, or Hydrology _____ significantly disturbed? Are "Normal Circumstances" present? Yes X No _____
 Are Vegetation _____, Soil _____, or Hydrology _____ naturally problematic? (If needed, explain any answers in Remarks.)

SUMMARY OF FINDINGS – Attach site map showing sampling point locations, transects, important features, etc.

| | | | | | |
|--|-----------|-------------|---------------------------------------|-----------|-------------|
| Hydrophytic Vegetation Present? | Yes _____ | No <u>X</u> | Is the Sampled Area within a Wetland? | Yes _____ | No <u>X</u> |
| Hydric Soil Present? | Yes _____ | No <u>X</u> | | | |
| Wetland Hydrology Present? | Yes _____ | No <u>X</u> | | | |
| Remarks: <u>~170% above normal rainfall for the season</u> | | | | | |

VEGETATION – Use scientific names of plants.

| Tree Stratum (Plot size: _____) | Absolute % Cover | Dominant Species? | Indicator Status | Dominance Test worksheet: |
|--|------------------|-------------------|------------------|--|
| 1. <u>Picea sitchensis</u> | <u>10</u> | <u>✓</u> | <u>FAC</u> | Number of Dominant Species That Are OBL, FACW, or FAC: <u>2</u> (A) |
| 2. _____ | _____ | _____ | _____ | Total Number of Dominant Species Across All Strata: <u>4</u> (B) |
| 3. _____ | _____ | _____ | _____ | Percent of Dominant Species That Are OBL, FACW, or FAC: <u>50%</u> (A/B) |
| 4. _____ | _____ | _____ | _____ | |
| <u>10</u> = Total Cover | | | | |
| Sapling/Shrub Stratum (Plot size: _____) | Absolute % Cover | Dominant Species? | Indicator Status | Prevalence Index worksheet: |
| 1. <u>Rubus ursinus</u> | <u>13</u> | <u>✓</u> | <u>FACU</u> | Total % Cover of: _____ Multiply by: _____ |
| 2. <u>Baccharis pilularis</u> | <u>20</u> | <u>✓</u> | <u>NL</u> | OBL species _____ x 1 = _____ |
| 3. _____ | _____ | _____ | _____ | FACW species _____ x 2 = _____ |
| 4. _____ | _____ | _____ | _____ | FAC species _____ x 3 = _____ |
| 5. _____ | _____ | _____ | _____ | FACU species _____ x 4 = _____ |
| <u>33</u> = Total Cover <u>16.5</u> <u>6.8</u> | | | | UPL species _____ x 5 = _____ |
| | | | | Column Totals: _____ (A) _____ (B) |
| | | | | Prevalence Index = B/A = _____ |
| Herb Stratum (Plot size: _____) | Absolute % Cover | Dominant Species? | Indicator Status | Hydrophytic Vegetation Indicators: |
| 1. <u>Phalaris arundinacea</u> | <u>30</u> | <u>✓</u> | <u>FACW</u> | ___ 1 - Rapid Test for Hydrophytic Vegetation |
| 2. <u>Cyperus dissectum</u> | <u>1</u> | _____ | <u>NL</u> | ___ 2 - Dominance Test is >50% |
| 3. <u>Polystichum munitum</u> | <u>1</u> | _____ | <u>FACU</u> | ___ 3 - Prevalence Index is ≤3.0 ¹ |
| 4. _____ | _____ | _____ | _____ | ___ 4 - Morphological Adaptations ¹ (Provide supporting data in Remarks or on a separate sheet) |
| 5. _____ | _____ | _____ | _____ | ___ 5 - Wetland Non-Vascular Plants ¹ |
| 6. _____ | _____ | _____ | _____ | ___ Problematic Hydrophytic Vegetation ¹ (Explain) |
| 7. _____ | _____ | _____ | _____ | ¹ Indicators of hydric soil and wetland hydrology must be present, unless disturbed or problematic. |
| 8. _____ | _____ | _____ | _____ | |
| 9. _____ | _____ | _____ | _____ | |
| 10. _____ | _____ | _____ | _____ | |
| 11. _____ | _____ | _____ | _____ | |
| <u>32</u> = Total Cover <u>16</u> <u>2.4</u> | | | | |
| Woody Vine Stratum (Plot size: _____) | Absolute % Cover | Dominant Species? | Indicator Status | Hydrophytic Vegetation Present? |
| 1. _____ | _____ | _____ | _____ | Yes _____ No <u>X</u> |
| 2. _____ | _____ | _____ | _____ | |
| % Bare Ground in Herb Stratum <u>68%</u> = Total Cover | | | | |
| Remarks: <u>background due to shade from shrub and tree layer. Diff.</u> | | | | |

SOIL

Sampling Point: TP4

Profile Description: (Describe to the depth needed to document the indicator or confirm the absence of indicators.)

| Depth (inches) | Matrix | | Redox Features | | | | Texture | Remarks |
|----------------|---------------|-----|----------------|---|-------------------|------------------|---------|---------|
| | Color (moist) | % | Color (moist) | % | Type ¹ | Loc ² | | |
| 0-7 | 10 YR 2/2 | 100 | | | | | S | |
| 7-24 | 2.5Y 3/2 | 100 | | | | | S | |
| | | | | | | | | |
| | | | | | | | | |
| | | | | | | | | |
| | | | | | | | | |
| | | | | | | | | |
| | | | | | | | | |

¹Type: C=Concentration, D=Depletion, RM=Reduced Matrix, CS=Covered or Coated Sand Grains. ²Location: PL=Pore Lining, M=Matrix.

Hydric Soil Indicators: (Applicable to all LRRs, unless otherwise noted.)

Indicators for Problematic Hydric Soils³:

- | | | |
|--|---|---|
| <input type="checkbox"/> Histic Epipedon (A2) | <input type="checkbox"/> Sandy Redox (S5) | <input type="checkbox"/> 2 cm Muck (A10) |
| <input type="checkbox"/> Black Histic (A3) | <input type="checkbox"/> Stripped Matrix (S6) | <input type="checkbox"/> Red Parent Material (TF2) |
| <input type="checkbox"/> Hydrogen Sulfide (A4) | <input type="checkbox"/> Loamy Mucky Mineral (F1) (except MLRA 1) | <input type="checkbox"/> Very Shallow Dark Surface (TF12) |
| <input type="checkbox"/> Depleted Below Dark Surface (A11) | <input type="checkbox"/> Loamy Gleyed Matrix (F2) | <input type="checkbox"/> Other (Explain in Remarks) |
| <input type="checkbox"/> Thick Dark Surface (A12) | <input type="checkbox"/> Depleted Matrix (F3) | |
| <input type="checkbox"/> Sandy Mucky Mineral (S1) | <input type="checkbox"/> Redox Dark Surface (F6) | |
| <input type="checkbox"/> Sandy Gleyed Matrix (S4) | <input type="checkbox"/> Depleted Dark Surface (F7) | |
| | <input type="checkbox"/> Redox Depressions (F8) | |

³Indicators of hydrophytic vegetation and wetland hydrology must be present, unless disturbed or problematic.

Restrictive Layer (if present):

Type: _____
Depth (inches): _____

Hydric Soil Present? Yes _____ No

Remarks:

HYDROLOGY

Wetland Hydrology Indicators:

Primary Indicators (minimum of one required; check all that apply)

Secondary Indicators (2 or more required)

- | | | |
|--|---|--|
| <input checked="" type="checkbox"/> Surface Water (A1) | <input type="checkbox"/> Water-Stained Leaves (B9) (except MLRA 1, 2, 4A, and 4B) | <input type="checkbox"/> Water-Stained Leaves (B9) (MLRA 1, 2, 4A, and 4B) |
| <input checked="" type="checkbox"/> High Water Table (A2) | <input type="checkbox"/> Salt Crust (B11) | <input type="checkbox"/> Drainage Patterns (B10) |
| <input checked="" type="checkbox"/> Saturation (A3) | <input type="checkbox"/> Aquatic Invertebrates (B13) | <input type="checkbox"/> Dry-Season Water Table (C2) |
| <input type="checkbox"/> Water Marks (B1) | <input type="checkbox"/> Hydrogen Sulfide Odor (C1) | <input type="checkbox"/> Saturation Visible on Aerial Imagery (C9) |
| <input type="checkbox"/> Sediment Deposits (B2) | <input type="checkbox"/> Oxidized Rhizospheres along Living Roots (C3) | <input checked="" type="checkbox"/> Geomorphic Position (D2) |
| <input type="checkbox"/> Drift Deposits (B3) | <input type="checkbox"/> Presence of Reduced Iron (C4) | <input type="checkbox"/> Shallow Aquitard (D3) |
| <input type="checkbox"/> Algal Mat or Crust (B4) | <input type="checkbox"/> Recent Iron Reduction in Tilled Soils (C6) | <input type="checkbox"/> FAC-Neutral Test (D5) |
| <input type="checkbox"/> Iron Deposits (B5) | <input type="checkbox"/> Stunted or Stressed Plants (D1) (LRR A) | <input type="checkbox"/> Raised Ant Mounds (D6) (LRR A) |
| <input type="checkbox"/> Surface Soil Cracks (B6) | <input type="checkbox"/> Other (Explain in Remarks) | <input type="checkbox"/> Frost-Heave Hummocks (D7) |
| <input type="checkbox"/> Inundation Visible on Aerial Imagery (B7) | | |
| <input type="checkbox"/> Sparsely Vegetated Concave Surface (B8) | | |

Field Observations:

Surface Water Present? Yes _____ No Depth (inches): _____
 Water Table Present? Yes No _____ Depth (inches): 11 inches
 Saturation Present? Yes No _____ Depth (inches): 7 inches
 (includes capillary fringe)

see remarks
Wetland Hydrology Present? Yes _____ No

Describe Recorded Data (stream gauge, monitoring well, aerial photos, previous inspections), if available:

Remarks:

wetland hydrology reflects recent high rainfall amounts, and rain on day preceding field work. Note lack of hydrophytic vegetation or additional indicators

WETLAND DETERMINATION DATA FORM – Western Mountains, Valleys, and Coast Region

Project/Site: RMT II Samoa Effluent Pipeline City/County: Humboldt Sampling Date: 3/24/2017
 Applicant/Owner: Humboldt Bay Harbor District State: CA Sampling Point: TP5
 Investigator(s): Joseph Siler, Sam Polly Section, Township, Range: Sec. 15, 16, 17, T5N, R1W, HBM
 Landform (hillslope, terrace, etc.): Sandy Dunes, Ind. Site Local relief (concave, convex, none): Concave Slope (%): 2-3
 Subregion (LRR): A, MLRA, 4B Lat: 40.812757 Long: -124.90930 Datum: _____
 Soil Map Unit Name: Samoa-Clambeach-Dunelands, Industrial Fill NWI classification: PEM1C

Are climatic / hydrologic conditions on the site typical for this time of year? Yes _____ No (If no, explain in Remarks.)
 Are Vegetation _____, Soil _____, or Hydrology _____ significantly disturbed? Are "Normal Circumstances" present? Yes _____ No _____
 Are Vegetation _____, Soil _____, or Hydrology _____ naturally problematic? (If needed, explain any answers in Remarks.)

SUMMARY OF FINDINGS – Attach site map showing sampling point locations, transects, important features, etc.

| | |
|--|--|
| Hydrophytic Vegetation Present? Yes _____ No <input checked="" type="checkbox"/> Hydric Soil Present? Yes <input checked="" type="checkbox"/> No _____ Wetland Hydrology Present? Yes <input checked="" type="checkbox"/> No _____ | Is the Sampled Area within a Wetland? Yes <input checked="" type="checkbox"/> No _____ |
| Remarks: <u>~170% above normal rainfall for the season</u> | |

VEGETATION – Use scientific names of plants.

| Tree Stratum (Plot size: _____) | Absolute % Cover | Dominant Species? | Indicator Status | Dominance Test worksheet: | | | | | | | | | | | | | | | | |
|--|------------------|-------------------------------------|------------------|---|-------------------|--------------|----------------------|----------------|-----------------------|----------------|----------------------|----------------|-----------------------|-----------------|----------------------|----------------|-----------------------------|---------------|--------------------------------------|--|
| 1. _____ | _____ | _____ | _____ | Number of Dominant Species That Are OBL, FACW, or FAC: <u>1</u> (A) | | | | | | | | | | | | | | | | |
| 2. _____ | _____ | _____ | _____ | Total Number of Dominant Species Across All Strata: <u>3</u> (B) | | | | | | | | | | | | | | | | |
| 3. _____ | _____ | _____ | _____ | Percent of Dominant Species That Are OBL, FACW, or FAC: <u>33%</u> (A/B) | | | | | | | | | | | | | | | | |
| 4. _____ | _____ | _____ | _____ | Prevalence Index worksheet: <table style="width:100%; border-collapse: collapse;"> <tr> <td style="width:50%;">Total % Cover of:</td> <td style="width:50%;">Multiply by:</td> </tr> <tr> <td>OBL species <u>0</u></td> <td>x 1 = <u>0</u></td> </tr> <tr> <td>FACW species <u>0</u></td> <td>x 2 = <u>0</u></td> </tr> <tr> <td>FAC species <u>3</u></td> <td>x 3 = <u>9</u></td> </tr> <tr> <td>FACU species <u>3</u></td> <td>x 4 = <u>12</u></td> </tr> <tr> <td>UPL species <u>1</u></td> <td>x 5 = <u>5</u></td> </tr> <tr> <td>Column Totals: <u>7</u> (A)</td> <td><u>26</u> (B)</td> </tr> <tr> <td colspan="2" style="text-align: center;">Prevalence Index = B/A = <u>3.71</u></td> </tr> </table> | Total % Cover of: | Multiply by: | OBL species <u>0</u> | x 1 = <u>0</u> | FACW species <u>0</u> | x 2 = <u>0</u> | FAC species <u>3</u> | x 3 = <u>9</u> | FACU species <u>3</u> | x 4 = <u>12</u> | UPL species <u>1</u> | x 5 = <u>5</u> | Column Totals: <u>7</u> (A) | <u>26</u> (B) | Prevalence Index = B/A = <u>3.71</u> | |
| Total % Cover of: | Multiply by: | | | | | | | | | | | | | | | | | | | |
| OBL species <u>0</u> | x 1 = <u>0</u> | | | | | | | | | | | | | | | | | | | |
| FACW species <u>0</u> | x 2 = <u>0</u> | | | | | | | | | | | | | | | | | | | |
| FAC species <u>3</u> | x 3 = <u>9</u> | | | | | | | | | | | | | | | | | | | |
| FACU species <u>3</u> | x 4 = <u>12</u> | | | | | | | | | | | | | | | | | | | |
| UPL species <u>1</u> | x 5 = <u>5</u> | | | | | | | | | | | | | | | | | | | |
| Column Totals: <u>7</u> (A) | <u>26</u> (B) | | | | | | | | | | | | | | | | | | | |
| Prevalence Index = B/A = <u>3.71</u> | | | | | | | | | | | | | | | | | | | | |
| = Total Cover | | | | | | | | | | | | | | | | | | | | |
| Sapling/Shrub Stratum (Plot size: _____) | | | | | | | | | | | | | | | | | | | | |
| 1. _____ | _____ | _____ | _____ | Hydrophytic Vegetation Indicators: ___ 1 - Rapid Test for Hydrophytic Vegetation ___ 2 - Dominance Test is >50% ___ 3 - Prevalence Index is ≤3.0 ¹ ___ 4 - Morphological Adaptations ¹ (Provide supporting data in Remarks or on a separate sheet) ___ 5 - Wetland Non-Vascular Plants ¹ ___ Problematic Hydrophytic Vegetation ¹ (Explain) ¹ Indicators of hydric soil and wetland hydrology must be present, unless disturbed or problematic. | | | | | | | | | | | | | | | | |
| 2. _____ | _____ | _____ | _____ | | | | | | | | | | | | | | | | | |
| 3. _____ | _____ | _____ | _____ | | | | | | | | | | | | | | | | | |
| 4. _____ | _____ | _____ | _____ | | | | | | | | | | | | | | | | | |
| 5. _____ | _____ | _____ | _____ | | | | | | | | | | | | | | | | | |
| = Total Cover | | | | | | | | | | | | | | | | | | | | |
| Herb Stratum (Plot size: _____) | | | | | | | | | | | | | | | | | | | | |
| 1. <u>Heterantherus</u> | <u>15</u> | <input checked="" type="checkbox"/> | <u>FAC</u> | | | | | | | | | | | | | | | | | |
| 2. <u>Lotus corniculatus</u> | <u>12</u> | <input checked="" type="checkbox"/> | <u>FAC</u> | | | | | | | | | | | | | | | | | |
| 3. <u>Agrostis stolonifera</u> | <u>2</u> | <input checked="" type="checkbox"/> | <u>FAC</u> | | | | | | | | | | | | | | | | | |
| 4. <u>Briza maxima</u> | <u>18</u> | <input checked="" type="checkbox"/> | <u>NL</u> | | | | | | | | | | | | | | | | | |
| 5. <u>Anthoxanthum odoratum</u> | <u>14</u> | <input checked="" type="checkbox"/> | <u>FACU</u> | | | | | | | | | | | | | | | | | |
| 6. <u>Fragaria chiloensis</u> | <u>3</u> | <input checked="" type="checkbox"/> | <u>FACU</u> | | | | | | | | | | | | | | | | | |
| 7. <u>Plantago coronopus</u> | <u>2</u> | <input checked="" type="checkbox"/> | <u>FACU</u> | | | | | | | | | | | | | | | | | |
| 8. _____ | _____ | _____ | _____ | | | | | | | | | | | | | | | | | |
| 9. _____ | _____ | _____ | _____ | | | | | | | | | | | | | | | | | |
| 10. _____ | _____ | _____ | _____ | | | | | | | | | | | | | | | | | |
| 11. _____ | _____ | _____ | _____ | | | | | | | | | | | | | | | | | |
| <u>66</u> = Total Cover <u>33%</u> | | | | | | | | | | | | | | | | | | | | |
| Woody Vine Stratum (Plot size: _____) | | | | | | | | | | | | | | | | | | | | |
| 1. _____ | _____ | _____ | _____ | Hydrophytic Vegetation Present? Yes _____ No <input checked="" type="checkbox"/> | | | | | | | | | | | | | | | | |
| 2. _____ | _____ | _____ | _____ | | | | | | | | | | | | | | | | | |
| = Total Cover | | | | | | | | | | | | | | | | | | | | |
| % Bare Ground in Herb Stratum <u>34%</u> | | | | | | | | | | | | | | | | | | | | |
| Remarks: <u>Bare ground a result of pooled water, poor soil conditions</u> | | | | | | | | | | | | | | | | | | | | |

SOIL

Sampling Point: TP5

Profile Description: (Describe to the depth needed to document the indicator or confirm the absence of indicators.)

| Depth (inches) | Matrix | | Redox Features | | | | Texture | Remarks |
|----------------|---------------|-----|----------------|----|-------------------|------------------|---------|------------------------------|
| | Color (moist) | % | Color (moist) | % | Type ¹ | Loc ² | | |
| 0-5 | 10YR 2/1 | 100 | | | | | S | significant % organic matter |
| 5-24 | 5Y 2.5/1 | 61 | 2.5Y 3/3 | 1 | C | M | S | |
| | | | 2.5Y 3/2 | 38 | C | M | S | |
| | | | | | | | | |
| | | | | | | | | |
| | | | | | | | | |
| | | | | | | | | |
| | | | | | | | | |
| | | | | | | | | |
| | | | | | | | | |

¹Type: C=Concentration, D=Depletion, RM=Reduced Matrix, CS=Covered or Coated Sand Grains. ²Location: PL=Pore Lining, M=Matrix.

Hydric Soil Indicators: (Applicable to all LRRs, unless otherwise noted.)

| | | |
|--|---|---|
| <input type="checkbox"/> Histosol (A1) | <input checked="" type="checkbox"/> Sandy Redox (S5) | <input type="checkbox"/> 2 cm Muck (A10) |
| <input type="checkbox"/> Histic Epipedon (A2) | <input type="checkbox"/> Stripped Matrix (S6) | <input type="checkbox"/> Red Parent Material (TF2) |
| <input type="checkbox"/> Black Histic (A3) | <input type="checkbox"/> Loamy Mucky Mineral (F1) (except MLRA 1) | <input type="checkbox"/> Very Shallow Dark Surface (TF12) |
| <input type="checkbox"/> Hydrogen Sulfide (A4) | <input type="checkbox"/> Loamy Gleyed Matrix (F2) | <input type="checkbox"/> Other (Explain in Remarks) |
| <input type="checkbox"/> Depleted Below Dark Surface (A11) | <input type="checkbox"/> Depleted Matrix (F3) | |
| <input type="checkbox"/> Thick Dark Surface (A12) | <input checked="" type="checkbox"/> Redox Dark Surface (F6) | ³ Indicators of hydrophytic vegetation and wetland hydrology must be present, unless disturbed or problematic. |
| <input type="checkbox"/> Sandy Mucky Mineral (S1) | <input type="checkbox"/> Depleted Dark Surface (F7) | |
| <input type="checkbox"/> Sandy Gleyed Matrix (S4) | <input type="checkbox"/> Redox Depressions (F8) | |

Restrictive Layer (if present):

Type: _____

Depth (inches): _____

Hydric Soil Present? Yes No

Remarks:

HYDROLOGY

Wetland Hydrology Indicators:

| | | |
|---|---|---|
| Primary Indicators (minimum of one required; check all that apply) | | Secondary Indicators (2 or more required) |
| <input checked="" type="checkbox"/> Surface Water (A1) | <input type="checkbox"/> Water-Stained Leaves (B9) (except MLRA 1, 2, 4A, and 4B) | <input checked="" type="checkbox"/> Water-Stained Leaves (B9) (MLRA 1, 2, 4A, and 4B) |
| <input checked="" type="checkbox"/> High Water Table (A2) | <input checked="" type="checkbox"/> Salt Crust (B11) | <input checked="" type="checkbox"/> Drainage Patterns (B10) |
| <input checked="" type="checkbox"/> Saturation (A3) | <input checked="" type="checkbox"/> Aquatic Invertebrates (B13) | <input type="checkbox"/> Dry-Season Water Table (C2) |
| <input checked="" type="checkbox"/> Water Marks (B1) | <input type="checkbox"/> Hydrogen Sulfide Odor (C1) | <input type="checkbox"/> Saturation Visible on Aerial Imagery (C9) |
| <input type="checkbox"/> Sediment Deposits (B2) | <input type="checkbox"/> Oxidized Rhizospheres along Living Roots (C3) | <input checked="" type="checkbox"/> Geomorphic Position (D2) |
| <input type="checkbox"/> Drift Deposits (B3) | <input type="checkbox"/> Presence of Reduced Iron (C4) | <input type="checkbox"/> Shallow Aquitard (D3) |
| <input type="checkbox"/> Algal Mat or Crust (B4) | <input type="checkbox"/> Recent Iron Reduction in Tilled Soils (C6) | <input type="checkbox"/> FAC-Neutral Test (D5) |
| <input type="checkbox"/> Iron Deposits (B5) | <input type="checkbox"/> Stunted or Stressed Plants (D1) (LRR A) | <input type="checkbox"/> Raised Ant Mounds (D6) (LRR A) |
| <input type="checkbox"/> Surface Soil Cracks (B6) | <input type="checkbox"/> Other (Explain in Remarks) | <input type="checkbox"/> Frost-Heave Hummocks (D7) |
| <input type="checkbox"/> Inundation Visible on Aerial Imagery (B7) | | |
| <input checked="" type="checkbox"/> Sparsely Vegetated Concave Surface (B8) | | |

Field Observations:

Surface Water Present? Yes No Depth (inches): 4 inches (2 ft from TP)

Water Table Present? Yes No Depth (inches): 4 inches

Saturation Present? (includes capillary fringe) Yes No Depth (inches): Surface

Wetland Hydrology Present? Yes No

Describe Recorded Data (stream gauge, monitoring well, aerial photos, previous inspections), if available:

Remarks:

WETLAND DETERMINATION DATA FORM – Western Mountains, Valleys, and Coast Region

Project/Site: RMT-II Samoa Effluent Pipeline City/County: Humboldt Sampling Date: 3/24/2017
 Applicant/Owner: Humboldt Bay Harbor District State: CA Sampling Point: TP6
 Investigator(s): Sam Pally, Joseph Saler Section, Township, Range: Sec. 15, 16, + 17, T5N, R1W, HBM
 Landform (hillslope, terrace, etc.): Sandy Dunes, Indust. Site Local relief (concave, convex, none): Concave Slope (%): 0-1
 Subregion (LRR): A, MLRA, 4B Lat: 40.812757° Long: -124.190930 Datum: _____
 Soil Map Unit Name: Samoa-Clambeach-Dunelands, Industrial fill NWI classification: PEM 1C

Are climatic / hydrologic conditions on the site typical for this time of year? Yes _____ No X (If no, explain in Remarks.)
 Are Vegetation _____, Soil _____, or Hydrology _____ significantly disturbed? Are "Normal Circumstances" present? Yes _____ No _____
 Are Vegetation _____, Soil _____, or Hydrology _____ naturally problematic? (If needed, explain any answers in Remarks.)

SUMMARY OF FINDINGS – Attach site map showing sampling point locations, transects, important features, etc.

| | |
|---|---|
| Hydrophytic Vegetation Present? Yes _____ No <u>X</u> Hydric Soil Present? Yes <u>X</u> No _____ Wetland Hydrology Present? Yes <u>X</u> No _____ | Is the Sampled Area within a Wetland? Yes <u>X</u> No _____ |
| Remarks: <u>~170% above normal rainfall for the season.</u> | |

VEGETATION – Use scientific names of plants.

| Tree Stratum (Plot size: _____) | Absolute % Cover | Dominant Species? | Indicator Status | Dominance Test worksheet: |
|--|------------------|-------------------|------------------|--|
| 1. _____ | | | | Number of Dominant Species That Are OBL, FACW, or FAC: <u>1</u> (A) |
| 2. _____ | | | | Total Number of Dominant Species Across All Strata: <u>2</u> (B) |
| 3. _____ | | | | Percent of Dominant Species That Are OBL, FACW, or FAC: <u>50%</u> (A/B) |
| 4. _____ | | | | |
| = Total Cover | | | | |
| Sapling/Shrub Stratum (Plot size: _____) | Absolute % Cover | Dominant Species? | Indicator Status | Prevalence Index worksheet: |
| 1. _____ | | | | Total % Cover of: _____ Multiply by: _____ |
| 2. _____ | | | | OBL species <u>0</u> x 1 = <u>0</u> |
| 3. _____ | | | | FACW species <u>1</u> x 2 = <u>2</u> |
| 4. _____ | | | | FAC species <u>1</u> x 3 = <u>3</u> |
| 5. _____ | | | | FACU species <u>2</u> x 4 = <u>8</u> |
| = Total Cover | | | | UPL species <u>6</u> x 5 = <u>30</u> |
| | | | | Column Totals: <u>10</u> (A) <u>43</u> (B) |
| | | | | Prevalence Index = B/A = <u>4.3</u> |
| Herb Stratum (Plot size: _____) | Absolute % Cover | Dominant Species? | Indicator Status | Hydrophytic Vegetation Indicators: |
| 1. <u>Juncus lescarii</u> | <u>30</u> | <u>✓</u> | <u>FACW</u> | ___ 1 - Rapid Test for Hydrophytic Vegetation |
| 2. <u>Holcus lanatus</u> | <u>6</u> | | <u>FAC</u> | ___ 2 - Dominance Test is >50% |
| 3. <u>Fragaria chilensis</u> | <u>1</u> | | <u>FACU</u> | ___ 3 - Prevalence Index is ≤3.0 ¹ |
| 4. <u>Brida maxima</u> | <u>28</u> | <u>✓</u> | <u>NL</u> | ___ 4 - Morphological Adaptations ¹ (Provide supporting data in Remarks or on a separate sheet) |
| 5. <u>Ammophila arenaria</u> | <u>5</u> | | <u>FACU</u> | ___ 5 - Wetland Non-Vascular Plants ¹ |
| 6. <u>Polygonum paronychia</u> | <u>3</u> | | <u>NL</u> | ___ Problematic Hydrophytic Vegetation ¹ (Explain) |
| 7. <u>Geranium dissectum</u> | <u>1</u> | | <u>NL</u> | ¹ Indicators of hydric soil and wetland hydrology must be present, unless disturbed or problematic. |
| 8. <u>Cardiomena ramosissimum</u> | <u>1</u> | | <u>NL</u> | |
| 9. <u>Vicia sativa</u> | <u>1</u> | | <u>UPL</u> | |
| 10. <u>Festuca microstachys</u> | <u>10</u> | | <u>NL</u> | |
| 11. _____ | | | | |
| <u>85</u> = Total Cover <u>43/172</u> | | | | |
| Woody Vine Stratum (Plot size: _____) | Absolute % Cover | Dominant Species? | Indicator Status | Hydrophytic Vegetation Present? |
| 1. _____ | | | | Yes _____ No <u>X</u> |
| 2. _____ | | | | |
| % Bare Ground in Herb Stratum <u>4</u> = Total Cover | | | | |
| Remarks: | | | | |

SOIL

Sampling Point: TPG

Profile Description: (Describe to the depth needed to document the indicator or confirm the absence of indicators.)

| Depth (inches) | Matrix | | Redox Features | | | | Texture | Remarks |
|----------------|---------------|-----|----------------|----|-------------------|------------------|---------|---------|
| | Color (moist) | % | Color (moist) | % | Type ¹ | Loc ² | | |
| 0-2 | 10YR 2/1 | 100 | | | | | S | |
| 2-8 | 2.5Y 3/2 | 67 | 10YR 3/3 | 3 | C | PL | S | |
| | | | 5Y 3/2 | 30 | C | M | | |
| 8-24+ | 5Y 3/1 | 100 | | | | | S | |
| | | | | | | | | |
| | | | | | | | | |
| | | | | | | | | |
| | | | | | | | | |

¹Type: C=Concentration, D=Depletion, RM=Reduced Matrix, CS=Covered or Coated Sand Grains. ²Location: PL=Pore Lining, M=Matrix.

Hydric Soil Indicators: (Applicable to all LRRs, unless otherwise noted.)

| | | |
|--|---|---|
| <input type="checkbox"/> Histosol (A1) | <input checked="" type="checkbox"/> Sandy Redox (S5) | <input type="checkbox"/> 2 cm Muck (A10) |
| <input type="checkbox"/> Histic Epipedon (A2) | <input type="checkbox"/> Stripped Matrix (S6) | <input type="checkbox"/> Red Parent Material (TF2) |
| <input type="checkbox"/> Black Histic (A3) | <input type="checkbox"/> Loamy Mucky Mineral (F1) (except MLRA 1) | <input type="checkbox"/> Very Shallow Dark Surface (TF12) |
| <input type="checkbox"/> Hydrogen Sulfide (A4) | <input type="checkbox"/> Loamy Gleyed Matrix (F2) | <input type="checkbox"/> Other (Explain in Remarks) |
| <input type="checkbox"/> Depleted Below Dark Surface (A11) | <input type="checkbox"/> Depleted Matrix (F3) | |
| <input type="checkbox"/> Thick Dark Surface (A12) | <input checked="" type="checkbox"/> Redox Dark Surface (F6) | ³ Indicators of hydrophytic vegetation and wetland hydrology must be present, unless disturbed or problematic. |
| <input type="checkbox"/> Sandy Mucky Mineral (S1) | <input type="checkbox"/> Depleted Dark Surface (F7) | |
| <input type="checkbox"/> Sandy Gleyed Matrix (S4) | <input type="checkbox"/> Redox Depressions (F8) | |

Restrictive Layer (if present):

Type: _____
 Depth (inches): _____

Hydric Soil Present? Yes No

Remarks: - Reduced matrix observed in second horizon

HYDROLOGY

Wetland Hydrology Indicators:

| | |
|---|--|
| Primary Indicators (minimum of one required; check all that apply) | Secondary Indicators (2 or more required) |
| <input type="checkbox"/> Surface Water (A1) | <input type="checkbox"/> Water-Stained Leaves (B9) (MLRA 1, 2, 4A, and 4B) |
| <input checked="" type="checkbox"/> High Water Table (A2) | <input type="checkbox"/> Drainage Patterns (B10) |
| <input checked="" type="checkbox"/> Saturation (A3) | <input type="checkbox"/> Dry-Season Water Table (C2) |
| <input type="checkbox"/> Water Marks (B1) | <input type="checkbox"/> Saturation Visible on Aerial Imagery (C9) |
| <input type="checkbox"/> Sediment Deposits (B2) | <input checked="" type="checkbox"/> Geomorphic Position (D2) |
| <input type="checkbox"/> Drift Deposits (B3) | <input type="checkbox"/> Shallow Aquitard (D3) |
| <input type="checkbox"/> Algal Mat or Crust (B4) | <input type="checkbox"/> FAC-Neutral Test (D5) |
| <input type="checkbox"/> Iron Deposits (B5) | <input type="checkbox"/> Raised Ant Mounds (D6) (LRR A) |
| <input type="checkbox"/> Surface Soil Cracks (B6) | <input type="checkbox"/> Frost-Heave Hummocks (D7) |
| <input type="checkbox"/> Inundation Visible on Aerial Imagery (B7) | |
| <input type="checkbox"/> Sparsely Vegetated Concave Surface (B8) | |

Field Observations:

Surface Water Present? Yes No Depth (inches): _____

Water Table Present? Yes No Depth (inches): 7 inches

Saturation Present? (includes capillary fringe) Yes No Depth (inches): 3 inches

Wetland Hydrology Present? Yes No

Describe Recorded Data (stream gauge, monitoring well, aerial photos, previous inspections), if available:

Remarks:

Figure 19-81 Rainfall documentation form

Date 3/27/17

Weather station Woodley Island

County Humboldt (06023)

Soil name _____

Photo date _____

Rainfall Documentation
(Use with photographs)

Landowner Humb. Bay Harbor Dist. Tract no. _____

State CA

Growing season _____

| | | Long-term rainfall records | | | Rain fall | Condition dry, wet, normal | Condition value | Month weight value | Product of previous to columns |
|-----------------|-----------------------|----------------------------|-----------------------|-------------|--------------|----------------------------|-----------------|--------------------|--------------------------------|
| Month | 3 yrs in 10 less then | Normal | 3 yrs in 10 more then | | | | | | |
| 1st Prior month | <u>Mar</u> | <u>3.80</u> | <u>5.54</u> | <u>6.61</u> | <u>7.18</u> | <u>Wet</u> | <u>3</u> | <u>3</u> | <u>9</u> |
| 2nd Prior month | <u>Feb</u> | <u>3.57</u> | <u>5.51</u> | <u>6.63</u> | <u>11.10</u> | <u>Wet</u> | <u>3</u> | <u>2</u> | <u>6</u> |
| 3rd Prior month | <u>Jan</u> | <u>3.67</u> | <u>5.97</u> | <u>7.22</u> | <u>10.51</u> | <u>Wet</u> | <u>3</u> | <u>1</u> | <u>3</u> |
| | | | | | | | | Sum | <u>18</u> |

Compared to photo date

Note: If sum is

6-9 Then prior period had been drier than normal

10-15 Then prior period has been normal

15-18 Then prior period has been wetter than normal

Condition value

Dry =1

Normal =2

Wet =3

Conclusion: Wetter than Normal



Appendix B – WDR No. R1-2001-62
Town of Samoa Wastewater Treatment
Facilities

DRAFT

DRAFT

California Regional Water Quality Control Board
North Coast Region

ORDER NO. R1-2001-62
ID NO. 1B85017RHUM
WASTE DISCHARGE REQUIREMENTS

FOR

SAMOA PACIFIC, LLC
TOWN OF SAMOA
WASTEWATER TREATMENT FACILITIES

Humboldt County

The California Regional Water Quality Control Board, North Coast Region (hereinafter Regional Water Board), finds that:

1. The Samoa Pacific, LLC (hereinafter Discharger) submitted a Report of Waste Discharge dated March 21, 2001.
2. The Discharger purchased the town of Samoa from Simpson Timber Company in December 2000. Samoa is located Two miles northwest of Eureka on the Samoa Peninsula of Humboldt Bay Samoa in Section 16, Township 5 North, Range 1 West, Humboldt (Latitude N 40° 49', Longitude W 124° 11'), as shown on Attachment A, incorporated herein and made part of this Order.
3. There are two separate wastewater treatment facilities currently in use in Samoa. The western system serves twenty-five homes and consists of a septic tank and leachfield. Its design capacity is reported to be 7,500 gallons per day (gpd). The leachfield is located west of Navy Base Road. The eastern system serves seventy-five homes, the hostelry, and the Samoa Cookhouse. It consists of a septic tank, two bark filters, an oxidation treatment pond, and a percolation basin. The western system leachfield is within the watershed of the Pacific Ocean. The eastern system is located within the watersheds of Humboldt Bay and the Pacific Ocean. The general layout of the western and eastern systems is shown on Attachment B, incorporated herein and made part of this Order.
4. The Water Quality Control Plan for the North Coast Region (Basin Plan) includes water quality objectives and receiving water limitations.
5. The beneficial uses of Humboldt Bay include:
 - a. industrial service supply
 - b. navigation
 - c. water contact recreation
 - d. noncontact water recreation
 - e. commercial and sport fishing
 - f. wildlife habitat
 - g. preservation of rare, threatened or endangered species
 - h. marine habitat
 - i. migration of aquatic organisms

- j. spawning, reproduction, and/or early development of fish
 - k. shellfish harvesting
 - l. estuarine habitat
 - m. aquaculture
6. The beneficial uses of the Pacific Ocean include:
- a. industrial service supply
 - b. industrial process supply
 - c. navigation
 - d. water contact recreation
 - e. noncontact water recreation
 - f. commercial and sport fishing
 - g. preservation of areas of special biological significance
 - h. wildlife habitat
 - i. preservation of rare, threatened or endangered species
 - j. marine habitat
 - k. migration of aquatic organisms
 - l. spawning, reproduction, and/or early development of fish
 - m. shellfish harvesting
 - n. aquaculture
7. Beneficial uses of areal groundwaters include:
- a. agricultural water supply
 - b. industrial service supply
 - c. industrial process supply
8. The western system is presently governed by Waste Discharge Requirements Order No. 85-40 adopted by the Regional Water Board on March 27, 1985. The eastern system is not regulated by a Regional Water Board order.
9. As per the Annual Fee Schedule contained in Title 23, Division 3, Chapter 9 of the California Code of Regulations Regional Water Board staff has determined that this facility (eastern and western systems) has a threat to water quality and complexity rating of 2-B with an annual fee of \$1,200.
10. This project is exempt from provisions of the California Environmental Quality Act (Public Resources Code Section 21000 et seq.) because it consists of the operation, repair, maintenance, permitting, leasing, licensing or minor alteration of an existing facility involving no or negligible expansion of use under California Code of Regulations, Title 14, Section 15301.
11. The permitted discharge is consistent with the provisions of State Water Resources Control Board Resolution No. 68-16, "Statement of Policy with Respect to Maintaining High Quality of Waters in California". The impact on existing water quality will be insignificant.

12. The Regional Water Board has notified the Discharger and interested agencies and persons of its intent to prescribe waste discharge requirements for the discharge and has provided them with an opportunity to submit their written comments and recommendations.
13. The Regional Water Board, in a public meeting, heard and considered all comments pertaining to the discharge.

THEREFORE, IT IS HEREBY ORDERED that Waste Discharge Requirements Order No. 85-40 is rescinded and the Discharger, in order to meet the provisions contained in Division 7 of the California Water Code (CWC) and regulations adopted thereunder, shall comply with the following:

A. DISCHARGE PROHIBITIONS

1. The discharge of any waste not specifically regulated by this Order is prohibited.
2. Creation of a pollution, contamination, or nuisance, as defined by CWC Section 13050 is prohibited.
3. The discharge of waste to land that is not under the control of the Discharger is prohibited, except as authorized under section **C. SOLIDS DISPOSAL**.
4. The discharge of untreated waste from anywhere within the collection, treatment, or disposal facilities is prohibited.
5. The discharge of waste from the Town of Samoa collection, or treatment, or disposal facilities system to Humboldt Bay or the Pacific Ocean is prohibited.
6. The discharge of sludge is prohibited.

B. EFFLUENT LIMITATIONS

1. Representative samples of the discharge from the eastern system's oxidation treatment pond to the percolation basin shall not contain constituents in excess of the following limits:

| <u>Constituent</u> | <u>Unit</u> | <u>Monthly Average¹</u> | <u>Daily Maximum²</u> |
|--------------------|-------------|--|----------------------------------|
| BOD (20° C, 5-day) | mg/l | 50 | 80 |
| Suspended Solids | mg/l | 50 | 80 |
| Settleable Solids | ml/l | 0.1 | 0.2 |
| Grease and Oil | ml/l | 25 | 50 |
| Hydrogen Ion | pH | Not less than 6.5 nor greater than 8.5 | |

¹ The arithmetic mean of all samples collected in a calendar month

² The maximum sample of all samples collected in a calendar day

2. The Discharger shall maintain at least two feet of freeboard in the eastern system's oxidation treatment pond and percolation basin. Vegetation surrounding the pond and basin shall be maintained to allow access, visual observation, and sampling.
3. Waste ponded within the eastern system's oxidation treatment pond shall not have a dissolved oxygen content of less than 1.0 milligram per liter (mg/l).
4. The mean daily flow of waste to the western system shall not exceed 7,500 gallons per day (gpd), averaged over a calendar month.
5. The discharge of all wastewater from the western system shall be kept underground at all times.

C. SOLIDS DISPOSAL

1. Collected screenings, scums, sludges, and other solids removed from liquid wastes shall be disposed at a legal point of disposal, and in accordance with the State Water Board promulgated provisions of Title 27, Division 2, of the California Code of Regulations.
2. Any proposed change in sludge use or a disposal practice from a previously approved practice shall be reported to the Executive Officer of the Regional Water Board (Executive Officer) at least 90 days in advance of the change.

D. GENERAL PROVISIONS

1. Availability

A copy of this Order shall be maintained at the discharge facility and be available at all times to operating personnel.

2. Severability

Provisions of these waste discharge requirements are severable. If any provision of these requirements is found invalid, the remainder of these requirements shall not be affected.

3. Operation and Maintenance

The Discharger shall maintain in good working order and operate as efficiently as possible any facility or control system installed by the Discharger to achieve compliance with the waste discharge requirements.

4. Change in Discharge

The Discharger shall file a report of waste discharge at least 120 days before making any material change or proposed change in the character, location, or volume of the discharge.

5. Change in Ownership

In the event of any change in control or ownership of land or waste discharge facilities presently owned or controlled by the Discharger, the Discharger shall notify the succeeding owner or operator of the following items by letter, a copy of which shall be forwarded to the Regional Water Board:

- a. existence of this Order, and
- b. the status of the Discharger's annual fee account

6. Vested Rights

This Order does not convey any property rights of any sort or any exclusive privileges. The requirements prescribed herein do not authorize the commission of any act causing injury to persons or property, nor protect the Discharger from liability under federal, State, or local laws, nor create a vested right for the Discharger to continue the waste discharge.

7. Monitoring

The Discharger shall comply with the Contingency Planning and Notification Requirements Order No. 74-151 and the Monitoring and Reporting Program No. R1-2001-62 and any modifications to these documents as specified by the Executive Officer. Such documents are attached to this Order and incorporated herein. Chemical, bacteriological, and bioassay analyses shall be conducted at a laboratory certified for such analyses by the State Department of Health Services.

8. Inspections

The Discharger shall permit authorized staff of the Regional Water Board:

- a. Entry upon premises in which an effluent source is located or in which any required records are kept;
- b. Access to copy any records required to be kept under terms and conditions of this Order;
- c. Inspection of monitoring equipment or records; and
- d. Sampling of any discharge.

9. Noncompliance

In the event the Discharger is unable to comply with any of the conditions of this Order due to:

- a. Breakdown of waste treatment equipment;
- b. Accidents caused by human error or negligence; or
- c. Other causes such as acts of nature.

The Discharger shall notify the Executive Officer by telephone as soon as it or its agents have knowledge of the incident and confirm this notification in writing within two weeks of the telephone notification. The written notification shall include pertinent information explaining

reasons for the noncompliance and shall indicate the steps taken to correct the problem and the dates thereof, and the steps being taken to prevent the problem from recurring.

10. Operator Certification

Supervisors and operators of the wastewater treatment facilities shall possess a certificate of appropriate grade in accordance with Title 23, CCR Section 3680. The State Water Board may accept experience in lieu of qualification training.

Certification

I, Lee A. Michlin, Executive Officer, do hereby certify that the foregoing is a full, true, and correct copy of an Order adopted by the California Regional Water Quality Control Board, North Coast Region, on June 28, 2001.

Lee A. Michlin
Executive Officer

(Samoa WDR.doc)

DRAFT



Appendix C – WDR No. R1-2012-0027
DG Fairhaven Power Facility

DRAFT

DRAFT

North Coast Regional Water Quality Control Board

ORDER NO. R1-2012-0027
NPDES NO. CA0024571
WDID NO. 1B85026RHUM

WASTE DISCHARGE REQUIREMENTS
 FOR DG FAIRHAVEN POWER, LLC
 FAIRHAVEN POWER FACILITY
 HUMBOLDT COUNTY

The following Discharger is subject to waste discharge requirements as set forth in this Order:

Table 1. Discharger Information

| | |
|---|--------------------------|
| Discharger | DG Fairhaven Power, LLC |
| Name of Facility | Fairhaven Power Facility |
| Facility Address | 97 Bay Street |
| | Samoa, CA 95564 |
| | Humboldt County |
| The U.S. Environmental Protection Agency (USEPA) and the Regional Water Quality Control Board have classified this discharge as a minor discharge | |

The discharge by Fairhaven Power, LLC to the discharge points identified below is subject to waste discharge requirements as set forth in this Order:

Table 2. Discharge Location

| Discharge Point | Effluent Description | Discharge Point Latitude | Discharge Point Longitude | Receiving Water |
|------------------------|--|---------------------------------|----------------------------------|------------------------|
| 001 | Process Water Gross Effluent combined discharge (including: Low Volume Wastes and Cooling Tower Blowdown) following all treatment processes prior to contact with receiving water (Pacific Ocean). | 40° 49' 10" N | 124° 13' 32" W | Pacific Ocean |

| Discharge Point | Effluent Description | Discharge Point Latitude | Discharge Point Longitude | Receiving Water |
|-----------------|---|--------------------------|---------------------------|-----------------|
| 010 | Low volume wastewater (screw and bearing cooling process water, boiler blowdown, demineralizer back flush, and reverse osmosis concentrate) prior to commingling with cooling tower blowdown. | 40° 47' 57.2" N | 124° 12' 10.9" W | Pacific Ocean |
| 020 | Cooling tower blowdown process wastewater prior to commingling with low volume wastewaters. | 40° 47' 57.3" N | 124° 12' 11.5" W | Pacific Ocean |

Table 3. Administrative Information

| | |
|---|-----------------------|
| This Order was adopted by the Regional Water Quality Control Board on: | April 26, 2012 |
| This Order shall become effective on: | July 1, 2012 |
| This Order shall expire on: | June 30, 2017 |
| The Discharger shall file a Report of Waste Discharge in accordance with title 23, California Code of Regulations, as application for issuance of new waste discharge requirements no later than: | June 30, 2016 |

IT IS HEREBY ORDERED, that Order No. R1-2002-0076 is rescinded upon the effective date of this Order except for enforcement purposes, and, in order to meet the provisions contained in division 7 of the Water Code (commencing with section 13000) and regulations adopted thereunder, and the provisions of the federal Clean Water Act (CWA) and regulations and guidelines adopted thereunder, the Discharger shall comply with the requirements in this Order.

I, Catherine Kuhlman, Executive Officer, do hereby certify that this Order with all attachments is a full, true, and correct copy of an Order adopted by the California Regional Water Quality Control Board, North Coast Region, on April 26, 2012.

 Catherine Kuhlman, Executive Officer

Table of Contents

| | | |
|------|---|----|
| I. | Facility Information | 2 |
| II. | Findings..... | 2 |
| III. | Discharge Prohibitions | 9 |
| IV. | Effluent Limitations and Discharge Specifications..... | 10 |
| | A. Final Effluent Limitations | 10 |
| | B. Interim Effluent Limitations | 12 |
| | C. Land Discharge Specifications | 13 |
| | D. Reclamation Specifications | 13 |
| | E. Other Requirements | 13 |
| V. | Receiving Water Limitations..... | 13 |
| | A. Surface Water Limitations – Pacific Ocean (Discharge Point 001)..... | 13 |
| | B. Groundwater Limitations..... | 16 |
| VI. | Provisions..... | 16 |
| | A. Standard Provisions | 16 |
| | B. Monitoring and Reporting Program (MRP) | 17 |
| | C. Special Provisions | 17 |
| VII. | Compliance Determination | 23 |

List of Tables

| | | |
|----------|--|----|
| Table 1. | Discharger Information..... | 1 |
| Table 2. | Discharge Location | 1 |
| Table 3. | Administrative Information | 2 |
| Table 4. | Facility Information..... | 2 |
| Table 5. | Basin Plan Beneficial Uses | 6 |
| Table 6. | Ocean Plan Beneficial Uses | 7 |
| Table 7. | Effluent Limitations at Discharge Point 001 (Gross Effluent Monitoring Location M-001)..... | 11 |
| Table 8. | Effluent Limitations at Discharge Point 010 (Low Volume Waste Streams).... | 11 |
| Table 9. | Effluent Limitations at Discharge Point 020 (Cooling Tower Blowdown)..... | 12 |

List of Attachments

| | |
|--|-----|
| Attachment A – Definitions | A-1 |
| Attachment B – Map..... | B-1 |
| Attachment C – Flow Schematic | C-1 |
| Attachment D – Standard Provisions..... | D-1 |
| Attachment E – Monitoring and Reporting Program..... | E-1 |
| Attachment F – Fact Sheet..... | F-1 |

I. FACILITY INFORMATION

The following Discharger is subject to waste discharge requirements as set forth in this Order:

Table 4. Facility Information

| | |
|--|---|
| Discharger | DG Fairhaven Power, LLC |
| Name of Facility | Fairhaven Power Facility |
| Facility Address | 97 Bay Street |
| | Samoa, CA 95564 |
| | Humboldt County |
| Facility Contact, Title, and Phone | Bob Marino, General Manager, (707) 445-5434 |
| Mailing Address | Same as facility address |
| Type of Facility | Electrical Services (SIC Code 4911) |
| Facility Maximum Anticipated Discharge Flow | 0.350 million gallons per day (MGD) |
| Facility Median Discharge Flow | 0.146 million gallons per day (MGD) |

II. FINDINGS

The California Regional Water Quality Control Board, North Coast Region (hereinafter Regional Water Board), finds:

A. Background. DG Fairhaven Power, LLC (hereinafter Discharger) is the owner and operator of the Fairhaven Power Facility (hereinafter Facility) and is currently discharging pursuant to Order No. R1-2002-0076, Monitoring and Reporting Program (MRP) No. R1-2002-0076, and National Pollutant Discharge Elimination System (NPDES) Permit No. CA0024571, which was adopted on August 22, 2002. The terms and conditions of the current Order have been automatically continued and remain in effect until a new Waste Discharge Requirements (WDRs) and NPDES permit is adopted pursuant to this Order.

The Discharger submitted a Report of Waste Discharge, dated March 17, 2010, and applied for an NPDES permit renewal to discharge process water from the Facility.

For the purposes of this Order, references to the “discharger” or “permittee” in applicable federal and state laws, regulations, plans, or policy are held to be equivalent to references to the Discharger herein.

On September 22, 2005, the State Water Resources Control Board (State Water Board) approved the Discharger's Notice of Intent to Comply with the terms of the *General Permit to Discharge Storm Water Associated with Industrial Activity Excluding Construction Activity* (WQ Order No. 97-03-DWQ, hereinafter the General Industrial Storm Water Permit). All storm water discharges and associated monitoring will occur under the General Industrial Storm Water Permit

B. Facility Description. The Discharger owns and operates a power generation facility in Samoa, California. The Facility is located on the Samoa Peninsula of Humboldt Bay, with Humboldt Bay to the east and the Pacific Ocean to the west. The Facility was formerly owned by Eel River Sawmills and in April 2005 was acquired by DG Fairhaven Power, LLC. The Facility combusts wood waste to produce electricity using a steam-turbine power generation process. The Facility's power generation uses approximately 500,000 gallons of potable water per day sourced from the Humboldt Bay Municipal Water District. A large fraction of this water is lost to the atmosphere as steam and the remaining wastewater, approximately 145,000 gallons per day of process water, is discharged as effluent to the Pacific Ocean, a water of the United States.

Process water discharged under this Order consists of cooling tower blowdown, low volume wastes (including boiler water blowdown, screw and bearing cooling water, reverse osmosis concentrate, and demineralizer back-wash), and cooling tower cleaning wastes, an intermittent waste stream.

The process water is treated at various points in the power generation cycle before being discharged as effluent. A reverse osmosis unit and a demineralizer are used to reduce the total dissolved solids content in the boiler water. The demineralizer back-wash, boiler blowdown, and reverse osmosis permeate are then routed back to the cooling tower. More than 60% of the cooling tower water is evaporated. The remaining cooling tower water is blown down via a valve prior to passing through an oil/water separator and being discharged. A schematic of the process water flows is provided in Attachment C to this Order.

The process water is discharged to the Pacific Ocean via the Freshwater Tissue outfall (Discharge Point 001). The outfall is a 48-inch diameter pipeline that terminates approximately 1.5 miles off-shore.

Other process wastes that are not discharged to the Ocean under this permit include bottom ash wash water, and metal and chemical metal cleaning wastes. Bottom ash is a by-product of the combustion process that is produced at an approximate rate of 151 tons per month. Bottom ash contains uncombusted wood chips, rocks, metals, ash, and other debris. To reduce the volume of bottom ash for disposal, the Discharger has proposed to process the bottom ash by utilizing a separator system that includes a screw conveyor submerged in a

hopper half-full of bottom ash and half-full of water, a magnetic conveyor, reclaimed wood skimmer, and separated product containers. By submerging the bottom ash in water within the hopper, the organics will float, allowing for easy separation. The Discharger has proposed to apply this bottom ash wash water to the incoming fuel immediately prior to combustion. Metal and chemical metal cleaning wastes are produced intermittently during boiler cleaning operations, but they have not been characterized and are also proposed to be applied to the incoming fuel immediately prior to combustion. These two waste streams are regulated under the Facility General Industrial Storm Water Permit.

In 2009, the Regional Water Board issued ACL No. R1-2009-0042 that formalized an agreement between the Regional Water Board and the Discharger regarding the creation and rehabilitation of an area of freshwater wetlands located in close proximity to the Facility. A feasibility study is still being performed on this project in the context of various other alternatives. If this project or an alternative is deemed feasible, a new report of waste discharge application will be necessary in order to permit discharges to a new location.

- C. Legal Authorities.** This Order is issued pursuant to section 402 of the federal Clean Water Act (CWA) and implementing regulations adopted by the U.S. Environmental Protection Agency (USEPA) and chapter 5.5, division 7 of the California Water Code (commencing with section 13370). It shall serve as a NPDES permit for point source discharges from this facility to surface waters. This Order also serves as Waste Discharge Requirements (WDRs) for discharges to land.
- D. Background and Rationale for Requirements.** The Regional Water Board developed the requirements in this Order based on information submitted as part of the application, through monitoring and reporting programs, and other available information. The Fact Sheet (Attachment F), which contains background information, legal authorities and rationale for Order requirements, is hereby incorporated into this Order and constitutes part of the Findings for this Order. Attachments A through E are also incorporated into this Order.
- E. California Environmental Quality Act (CEQA).** Under Water Code Section 13389, this action to adopt an NPDES permit is exempt from the provisions of CEQA, Public Resources Code sections 21100-21177.
- F. Technology-based Effluent Limitations.** Section 301(b) of the CWA and implementing USEPA permit regulations at section 122.44, title 40 of the Code of Federal Regulations, require that permits include conditions meeting applicable technology-based requirements at a minimum, and any more stringent effluent limitations necessary to meet applicable water quality standards. As described in section IV.B.2 of the Fact Sheet, based on BPJ, the discharge authorized by this

Order must meet minimum federal technology-based requirements based on Effluent Limitations Guidelines, Pretreatment Standards, and New Source Performance Standards for the Steam Electric Power Generating Point Source Category in 40 CFR Part 423 (ELGs). The Regional Water Board has considered the factors listed in the California Water Code (CWC) sections 13241 and 13263 in establishing these requirements. A detailed discussion of the technology-based effluent limitations development is included in the Fact Sheet (Attachment F).

G. Water Quality-Based Effluent Limitations. Section 301(b) of the CWA and section 122.44(d) require that permits include limitations more stringent than applicable federal technology-based requirements where necessary to achieve applicable water quality standards.

Section 122.44(d)(1)(i) mandates that permits include effluent limitations for all pollutants that are or may be discharged at levels that have the reasonable potential to cause or contribute to an exceedance of a water quality standard, including numeric and narrative objectives within a standard. Where reasonable potential has been established for a pollutant, but there is no numeric criterion or objective for the pollutant, water quality-based effluent limitations (WQBELs) must be established using: (1) USEPA criteria guidance under CWA section 304(a), supplemented where necessary by other relevant information; (2) an indicator parameter for the pollutant of concern; or (3) a calculated numeric water quality criterion, such as a proposed state criterion or policy interpreting the state's narrative criterion, supplemented with other relevant information, as provided in section 122.44(d)(1)(vi).

H. Water Quality Control Plans. The Regional Water Board adopted a *Water Quality Control Plan for the North Coast Region* (hereinafter the Basin Plan) that designates beneficial uses, establishes water quality objectives, and contains implementation programs and policies to achieve those objectives for all waters addressed through the plan. In addition, the Basin Plan implements State Water Board Resolution No. 88-63, which establishes State policy that all waters, with certain exceptions, should be considered suitable or potentially suitable for municipal or domestic supply. Beneficial uses applicable to the Pacific Ocean and freshwater wetlands are described in Table 5, below.

Table 5. Basin Plan Beneficial Uses

| Discharge Point | Receiving Water Name | Beneficial Use(s) |
|-----------------|----------------------|---|
| 001 | Pacific Ocean | <p><u>Existing:</u></p> <ul style="list-style-type: none"> • Navigation (NAV) • Water Contact Recreation (REC1) • Non-Contact Water Recreation (REC2) • Commercial and Sport Fishing (COMM) • Marine Habitat (MAR) • Wildlife Habitat (WILD) • Preservation of Rare, Threatened, or Endangered Species (RARE) • Migration of Aquatic Organisms (MIGR) • Spawning, Reproduction, and/or Early Development (SPWN) • Shellfish Harvesting (SHELL) • Aquaculture (AQUA) <p><u>Potential:</u></p> <ul style="list-style-type: none"> • Industrial Service Supply (IND) • Industrial Process Supply (PRO) • Preservation of Areas of Special Biological Significance (ASBS) |

Requirements of this Order implement the Basin Plan.

The State Water Board adopted the *Water Quality Control Plan for control of Temperature in the Coastal and Interstate Water and Enclosed Bays and Estuaries of California* (Thermal Plan) on May 18, 1972, and amended this plan on September 18, 1975. This plan contains temperature objectives for coastal waters. Requirements of this Order implement the Thermal Plan.

- I. **California Ocean Plan.** The State Water Board adopted the Water Quality Control Plan for Ocean Waters of California, California Ocean Plan (Ocean Plan) in 1972 and amended it in 1978, 1983, 1988, 1990, 1997, 2000, 2005, and 2009. The State Water Board adopted the latest amendment on September 15, 2009 and it became effective on March 10, 2010. The Ocean Plan is applicable, in its entirety, to point source discharges to the ocean. The Ocean Plan identifies beneficial uses of ocean waters of the State to be protected as summarized below.

Table 6. Ocean Plan Beneficial Uses

| Discharge Point | Receiving Water Name | Beneficial Use(s) |
|-----------------|----------------------|--|
| 001 | Pacific Ocean | <u>Existing:</u> <ul style="list-style-type: none"> • Industrial Water Supply • Water Contact and Non-Contact Recreation (including aesthetic enjoyment) • Navigation • Commercial and Sport Fishing • Mariculture • Preservation and enhancement of designated Areas of Special Biological Significance (ASBS) • Rare and Endangered Species • Marine Habitat • Fish Migration • Fish Spawning; and • Shellfish Harvesting |

Requirements of this Order implement the Ocean Plan.

J. Alaska Rule. On March 30, 2000, USEPA revised its regulation that specifies when new and revised state and tribal water quality standards (WQS) become effective for CWA purposes. (section 131.21; 65 Fed. Reg. 24641 (April 27, 2000)). Under the revised regulation (also known as the Alaska rule), new and revised standards submitted to USEPA after May 30, 2000, must be approved by USEPA before being used for CWA purposes. The final rule also provides that standards already in effect and submitted to USEPA by May 30, 2000 may be used for CWA purposes, whether or not approved by USEPA.

K. Stringency of Requirements for Individual Pollutants. This Order contains both technology-based effluent limitations and WQBELs for individual pollutants. The technology-based effluent limitations consist of restrictions on total suspended solids, oil and grease, polychlorinated biphenyls (PCBs), free available chlorine, total recoverable zinc and the remaining priority pollutants. Restrictions on these pollutants are discussed in section IV.B.2 of the Fact Sheet. This Order's technology-based pollutant restrictions implement the minimum, applicable federal technology-based requirements.

WQBELs have been scientifically derived to implement water quality objectives that protect beneficial uses. Both the beneficial uses and the water quality objectives have been approved pursuant to federal law and are the applicable federal water quality standards. To the extent that toxic pollutant WQBELs were derived from the CTR, the CTR is the applicable standard pursuant to section 131.38. The scientific procedures for calculating the individual WQBELs for

priority pollutants discharged to the freshwater wetland are based on the CTR-SIP, which was approved by USEPA on May 18, 2000. Most beneficial uses and water quality objectives contained in the Basin Plan were approved under state law and submitted to and approved by USEPA prior to May 30, 2000. Any water quality objectives and beneficial uses submitted to USEPA prior to May 30, 2000, but not approved by USEPA before that date, are nonetheless “applicable water quality standards for purposes of the CWA” pursuant to section 131.21(c)(1). To the extent that toxic pollutant WQBELs were derived from Table B of the Ocean Plan, the Ocean Plan is the applicable standard pursuant to section 131.38. The scientific procedures for calculating the individual WQBELs for Table B parameters discharged to the Pacific Ocean are based on the Ocean Plan, which was approved by USEPA on October 8, 2010. Collectively, this Order’s restrictions on individual pollutants are no more stringent than required to implement the requirements of the CWA.

- L. Antidegradation Policy.** Section 131.12 requires that the State water quality standards include an antidegradation policy consistent with the federal policy. The State Water Board established California’s antidegradation policy in State Water Board Resolution No. 68-16. Resolution No. 68-16 incorporates the federal antidegradation policy where the federal policy applies under federal law. Resolution No. 68-16 requires that existing quality of waters be maintained unless degradation is justified based on specific findings. The Regional Water Board’s Basin Plan implements, and incorporates by reference, both the State and federal antidegradation policies. As discussed in detail in the Fact Sheet the permitted discharge is consistent with the antidegradation provision of section 131.12 and State Water Board Resolution No. 68-16.
- M. Anti-Backsliding Requirements.** Sections 402(o)(2) and 303(d)(4) of the CWA and federal regulations at 40 CFR § 122.44(l) prohibit backsliding in NPDES permits. These anti-backsliding provisions require effluent limitations in a reissued permit to be as stringent as those in the previous permit, with some exceptions where limitations may be relaxed. All effluent limitations in this Order are at least as stringent as the effluent limitations in Order No. R1-2002-0076.
- N. Endangered Species Act.** This Order does not authorize any act that results in the taking of a threatened or endangered species or any act that is now prohibited, or becomes prohibited in the future, under either the California Endangered Species Act (Fish and Game Code sections 2050 to 2097) or the Federal Endangered Species Act (16 U.S.C.A. sections 1531 to 1544). This Order requires compliance with effluent limitations, receiving water limits, and other requirements to protect the beneficial uses of waters of the State. The Discharger is responsible for meeting all requirements of the applicable Endangered Species Act.

- O. Monitoring and Reporting.** Section 122.48 requires that all NPDES permits specify requirements for recording and reporting monitoring results. Water Code sections 13267 and 13383 authorizes the Regional Water Board to require technical and monitoring reports. The Monitoring and Reporting Program establishes monitoring and reporting requirements to implement federal and State requirements. This Monitoring and Reporting Program is provided in Attachment E.
- P. Standard and Special Provisions.** Standard Provisions, which apply to all NPDES permits in accordance with section 122.41, and additional conditions applicable to specified categories of permits in accordance with section 122.42, are provided in Attachment D. The Discharger must comply with all standard provisions and with those additional conditions that are applicable under section 122.42. The Regional Water Board has also included in this Order special provisions applicable to the Discharger. A rationale for the special provisions contained in this Order is provided in the attached Fact Sheet.
- Q. Provisions and Requirements Implementing State Law.** The provisions/requirements in section V.C of this Order are included to implement State law only. These provisions/requirements are not required or authorized under the federal CWA; consequently, violations of these provisions/requirements are not subject to the enforcement remedies that are available for NPDES violations.
- R. Notification of Interested Parties.** The Regional Water Board has notified the Discharger and interested agencies and persons of its intent to prescribe Waste Discharge Requirements for the discharge and has provided them with an opportunity to submit their written comments and recommendations. Details of notification are provided in the Fact Sheet of this Order.
- S. Consideration of Public Comment.** The Regional Water Board, in a public meeting, heard and considered all comments pertaining to the discharge. Details of the Public Hearing are provided in the Fact Sheet of this Order.

III. DISCHARGE PROHIBITIONS

- A.** The discharge of any waste not disclosed by the Discharger or not within the reasonable contemplation of the Regional Water Board is prohibited.
- B.** The discharge of waste to Humboldt Bay is prohibited.
- C.** Creation of a pollution, contamination, or nuisance, as defined by section 13050 of the Water Code is prohibited.

- D. The discharge of domestic waste, treated or untreated, to surface waters is prohibited.
- E. The discharge of waste at any point not described in Finding II.B. or authorized by any State Water Board or other Regional Water Board permit is prohibited.
- F. The discharge of waste to land that is not owned by, or under agreement to use by, the Discharger is prohibited.
- G. The intentional introduction of pollutant-free wastewater to the collection, treatment, and disposal system for purposes of dilution is prohibited. The discharge of noncontact cooling water is not subject to this prohibition.
- H. The discharge of waste to shallow usable groundwaters of the Samoa Peninsula is prohibited. Notwithstanding this prohibition, the discharge of wastes from employee sanitary facilities in compliance with the North Coast Basin Plan Policy on the Control of Water Quality with Respect to On-Site Waste Treatment and Disposal Practices is authorized.
- I. Discharge of any radiological, chemical, or biological warfare agent, or high-level radioactive wastewater into the ocean is prohibited.
- J. Discharge of sludge directly into the ocean or into a waste stream that discharges to the ocean is prohibited.
- K. Discharge of metal cleaning wastes into the ocean or into a waste stream that discharges to the ocean is prohibited.

IV. EFFLUENT LIMITATIONS AND DISCHARGE SPECIFICATIONS

A. Final Effluent Limitations

1. Final Effluent Limitations – Discharge Point 001

- a. The Discharger shall maintain compliance with the following effluent limitations at Discharge Point 001, with compliance measured at Monitoring Location M-001 as described in the Monitoring and Reporting Program (Attachment E):

Table 7. Effluent Limitations at Discharge Point 001 (Gross Effluent Monitoring Location M-001)

| Parameters | Units | Effluent Limitations | | | |
|---------------------------|-----------------|-----------------------------|----------------------------|-----------------------|------------------------------------|
| | | 6-Month Median ¹ | Daily Maximum ² | Instantaneous Minimum | Instantaneous Maximum ³ |
| Copper, Total Recoverable | µg/L | 118 | 1162 | -- | 3200 |
| Copper, Total Recoverable | lb/day | 0.172 | 1.698 | -- | 4.749 |
| pH | s.u. | -- | -- | 6.0 | 9.0 |
| Acute Toxicity | TU _a | -- | 3.75 | -- | -- |
| Chronic Toxicity | TU _c | -- | 116 | -- | -- |

2. Final Effluent Limitations – Discharge Point 010

- a. The Discharger shall maintain compliance with the following effluent limitations for low volume wastes, with compliance measured at Monitoring Locations M-010, as described in the Monitoring and Reporting Program (Attachment E):

Table 8. Effluent Limitations at Discharge Point 010 (Low Volume Waste Streams)

| Parameter | Units | Effluent Limitations | | | | |
|------------------------------|-------|----------------------|----------------|---------------|-----------------------|-----------------------|
| | | 6-Month Median | 30-Day Average | Daily Maximum | Instantaneous Minimum | Instantaneous Maximum |
| Total Suspended Solids (TSS) | mg/L | -- | 30 | 100 | -- | -- |
| Oil and Grease | mg/L | -- | 15 | 20 | -- | -- |

¹ This six-month median limit shall apply as a moving median of daily values for any 180-day period in which daily values represent flow weighted average concentrations within a 24-hour period. For intermittent discharges, the daily value shall be considered to equal zero for days on which no discharge occurred based on Section III.C.4.f of the Ocean Plan.

² This daily maximum limit shall apply to flow weighted 24-hour composite samples based on Section III.C.4.g of the Ocean Plan.

³ This instantaneous maximum limit shall apply to grab sample determinations based on Section III.C.4.h of the Ocean Plan.

| Parameter | Units | Effluent Limitations | | | | |
|-----------|-------|----------------------|----------------|---------------|-----------------------|-----------------------|
| | | 6-Month Median | 30-Day Average | Daily Maximum | Instantaneous Minimum | Instantaneous Maximum |
| pH | s.u. | | | | 6.0 | 9.0 |

3. Final Effluent Limitations – Discharge Point 020

- a. The discharge of recirculated cooling water blowdown as defined by 40 CFR § 423.13 shall comply with the following effluent limitations at Discharge Point 020. Compliance shall be measured at Monitoring Location M-020 as described in the Monitoring and Reporting Program (Attachment E):

Table 9. Effluent Limitations at Discharge Point 020 (Cooling Tower Blowdown)

| Parameters | Units | Effluent Limitations | | | | | |
|----------------------------------|-------|----------------------|----------------------|----------------------|----------------------|-----------------------|-----------------------|
| | | 30-Day Average | Maximum Daily | Average ⁴ | Maximum ⁵ | Instantaneous Minimum | Instantaneous Maximum |
| Free Available Chlorine | mg/L | -- | -- | 0.2 | 0.5 | -- | -- |
| Chromium, Total Recoverable | mg/L | 0.2 | 0.2 | -- | -- | -- | -- |
| Zinc, Total Recoverable | mg/L | 1.0 | 1.0 | -- | -- | -- | -- |
| Priority Pollutants ⁶ | mg/L | No detectable amount | No detectable amount | -- | -- | -- | -- |
| pH | s.u. | -- | -- | -- | -- | 6.0 | 9.0 |

B. Interim Effluent Limitations

This section of the standardized permit form is not applicable.

⁴ The term “average concentration”, as it relates to chlorine discharge under ELGs at 40 CFR 423, means the average of analyses made over a single period of chlorine release which does not exceed two hours (See Attachment A).

⁵ The term “maximum concentration”, as it relates to chlorine discharge under ELGs at 40 CFR 423, means the maximum of analyses made over a single period of chlorine release which does not exceed two hours (See Attachment A).

⁶ Applies to those pollutants contained in chemicals added for cooling tower maintenance except Total Chromium and Total Zinc. Priority pollutants to be monitored shall be identified according to the requirements contained in section IX.A of the MRP.

C. Land Discharge Specifications

This section of the standardized permit form is not applicable.

D. Reclamation Specifications

This section of the standardized permit form is not applicable.

E. Other Requirements

This section of the standardized permit form is not applicable.

V. RECEIVING WATER LIMITATIONS

A. Surface Water Limitations – Pacific Ocean (Discharge Point 001)

The following receiving water conditions are based on water quality objectives established by the Ocean Plan and are a required part of this Order. The discharge of waste shall not cause the following water quality objectives to be violated upon completion of final dilution.

1. Bacterial Characteristics

a. Body Contact Standards

Within a zone bounded by the shoreline and a distance of 1,000 feet from the shoreline or the 30-foot depth contour, whichever is further from the shoreline, and in areas outside this zone used for water contact sports, as determined by the Regional Water Board (i.e., waters designated as REC-1), but including all kelp beds, the following bacteriological objectives shall be maintained throughout the water column:

30-Day Geometric Mean – The following standards are based on the geometric mean of the five most recent samples from each receiving water monitoring location:

- i.** Total coliform density shall not exceed 1,000 per 100 mL;
- ii.** Fecal coliform density shall not exceed 200 per 100 mL; and
- iii.** Enterococcus density shall not exceed 35 per 100 mL.

Single Sample Maximum:

- i.** Total coliform density shall not exceed 10,000 per 100 mL;
- ii.** Fecal coliform density shall not exceed 400 per 100 mL;
- iii.** Enterococcus density shall not exceed 104 per 100 mL; and

- iv. Total coliform density shall not exceed 1,000 per 100 mL when the fecal coliform to total coliform ratio exceeds 0.1

b. Shellfish Harvesting Standards

At all areas where shellfish may be harvested for human consumption, as determined by the Regional Water Board, the following bacteriological objectives shall be maintained throughout the water column:

- i. The median total coliform density shall not exceed 70 organisms per 100 mL, and in not more than 10 percent of samples shall coliform density exceed 230 organisms per 100 mL.

2. Physical Characteristics

- a. Floating particulates and grease and oil shall not be visible.
- b. The discharge of waste shall not cause aesthetically undesirable discoloration of the ocean surface.
- c. Natural light shall not be significantly reduced at any point outside the initial dilution zone as the result of the discharge of waste.
- d. The rate of deposition of inert solids and the characteristics of inert solids in ocean sediments shall not be changed such that benthic communities are degraded.

3. Chemical Characteristics

- a. The dissolved oxygen concentration shall not at any time be depressed more than 10 percent from that which occurs naturally as a result of the discharge of oxygen demanding waste material.
- b. The pH shall not be changed at any time more than 0.2 units from that which occurs naturally.
- c. The dissolved sulfide concentration of waters in and near sediments shall not be significantly increased above that present under natural conditions.
- d. The concentration of substances set forth in Chapter IV, Table B of the Ocean Plan in marine sediments shall not be increased to levels that would degrade indigenous biota.
- e. The concentration of organic materials in marine sediments shall not be increased to levels that would degrade marine life.

- f. Nutrient levels shall not cause objectionable aquatic growths or degrade indigenous biota.
- g. Discharges shall not cause exceedances of water quality objectives for ocean waters of the State established in Table B of the Ocean Plan.
- h. Discharge of radioactive waste shall not degrade marine life.

4. Biological Characteristics

- a. Marine communities, including vertebrate, invertebrate and plant species, shall not be degraded.
- b. The natural taste, odor, and color of fish, shellfish, or other marine resources used for human consumption shall not be altered.
- c. The concentration of organic materials in fish, shellfish, or other marine resources used for human consumption shall not bioaccumulate to levels that are harmful to human health.

5. General Standards

- a. The discharge shall not cause a violation of any applicable water quality standard for the receiving waters adopted by the Regional Water Board or the State Water Board as required by the Clean Water Act and regulations adopted thereunder.
- b. The discharge shall be essentially free of:
 - i. Material that is floatable or will become floatable upon discharge.
 - ii. Settleable material or substances that may form sediments that will degrade benthic communities or other aquatic life.
 - iii. Substances that will accumulate to toxic levels in marine waters, sediments or biota.
 - iv. Substances that significantly decrease natural light to benthic communities and other marine life.
 - v. Material that results in aesthetically undesirable discoloration of the ocean surface.

- c. Waste effluent shall be discharged in a manner that provides sufficient initial dilution to minimize the concentrations of substances not removed in the treatment.
- d. Location of waste discharges must be determined after a detailed assessment of the oceanographic characteristics and current patterns to assure that:
 - i. Pathogenic organisms and viruses are not present in areas where shellfish are harvested for human consumption or in areas used for swimming or other body contact sports.
 - ii. Natural water quality conditions are not altered in areas designated as being of special biological significance.
 - iii. Maximum protection is provided to the marine environment.
 - iv. The discharge does not adversely affect recreational beneficial uses such as surfing and beach walking.

B. Groundwater Limitations

This section is not applicable.

VI. PROVISIONS

A. Standard Provisions

- 1. Federal Standard Provisions.** The Discharger shall comply with all Standard Provisions included in Attachment D of this Order.
- 2. Regional Water Board Standard Provisions.** The Discharger shall comply with the following provisions:
 - a. Failure to comply with provisions or requirements of this Order, or violation of other applicable laws or regulations governing discharges from this facility, may subject the Discharger to administrative or civil liabilities, criminal penalties, and/or other enforcement remedies to ensure compliance. Additionally, certain violations may subject the Discharger to civil or criminal enforcement from appropriate local, state, or federal law enforcement entities.
 - b. In the event the Discharger does not comply or will be unable to comply for any reason, with any prohibition, interim or final effluent limitation, land discharge specification, reclamation specification, receiving water

limitation, or provision of this Order that may result in a significant threat to human health or the environment, such as inundation of treatment components, breach of pond containment, sanitary sewer overflow, irrigation runoff, etc., and/or that results in a discharge to a drainage channel or a surface water, the Discharger shall report orally and in writing to the Regional Water Board staff all unauthorized spills. Spill notification and reporting shall be conducted in accordance with section X.E. of the Monitoring and Reporting Program (Attachment E).

- c. Prior to making any change in the point of discharge, place of use, or purpose of use of treated wastewater that results in a decrease of flow in any portion of a watercourse, the Discharger must file a petition with the State Water Board, Division of Water Rights, and receive approval for such a change. (Water Code § 1211)

B. Monitoring and Reporting Program (MRP)

The Discharger shall comply with the MRP, and future revisions thereto, in Attachment E of this Order.

C. Special Provisions

1. Reopener Provisions

- a. **Standard Revisions.** If applicable water quality standards are promulgated or approved pursuant to section 303 of the CWA, or amendments thereto, the Regional Water Board may reopen this Order and make modifications in accordance with such revised standards.
- b. **Reasonable Potential.** This Order may be reopened for modification to include an effluent limitation if monitoring establishes that the discharge causes, or has the reasonable potential to cause or contribute to, an excursion above a water quality criterion or objective applicable to the receiving water.
- c. **Whole Effluent Toxicity (WET).** As a result of a Toxicity Reduction Evaluation (TRE), this Order may be reopened to include a limitation for a specific toxic pollutant identified by a TRE.

2. Special Studies, Technical Reports and Additional Monitoring Requirements

a. Toxicity Reduction Requirements

- i. **Whole Effluent Toxicity.** The MRP of this Order requires routine monitoring for whole effluent toxicity of Discharge Point 001 at Monitoring Location M-001 as described in section V of the MRP, to determine compliance with the Ocean Plan's water quality objective for chronic toxicity, implemented as an effluent limitation in Section IV, above. As established by the MRP, if chronic toxicity is measured in the effluent above 115 TUc, the Discharger shall conduct accelerated toxicity monitoring as specified in Section V of the MRP.

Results of accelerated toxicity monitoring will indicate a need to conduct a Toxicity Reduction Evaluation (TRE) if toxicity persists; or it will indicate that a return to routine toxicity monitoring is justified because persistent toxicity has not been identified by accelerated monitoring. TREs shall be conducted in accordance with the TRE Workplan prepared by the Discharger pursuant to section VI.C.2.a.ii. of this Order and section V.B.1 of the MRP.

- ii. **Toxicity Reduction Evaluations (TRE) Workplan.** The Discharger shall prepare and submit to the Regional Water Board Executive Officer a TRE Workplan within 90 days of the effective date of this Order, by **July 30, 2012**. This plan shall be reviewed and updated as necessary in order to remain current and applicable to the discharge and discharge facilities. The TRE Workplan shall describe the steps the Discharger intends to follow if toxicity is detected above the effluent limitation, and should include at least the following items:
 - (a) A description of the investigation and evaluation techniques that would be used to identify potential causes and sources of toxicity, effluent variability, and treatment system efficiency.
 - (b) A description of the Facility's methods of maximizing in-house treatment efficiency and good housekeeping practices.
 - (c) If a toxicity identification evaluation (TIE) is necessary, an indication of the person who would conduct the TIE (i.e., an in-house expert or an outside contractor).
- iii. **Toxicity Reduction Evaluation.** The TRE shall be conducted in accordance with the following:

- (a)** The TRE shall be initiated within 30 days of the date of completion of the accelerated monitoring test, required by section V of the MRP, if that test result exceeds the whole effluent toxicity limitation or trigger.
- (b)** The TRE shall be conducted in accordance with the Discharger's workplan.
- (c)** The TRE shall be in accordance with current technical guidance and reference material including, at a minimum, USEPA manual EPA/833B-99/002 or EPA/600/2-88/070.
- (d)** The TRE may end at any stage if, through monitoring results, it is determined that there is no longer consistent toxicity.
- (e)** The Discharger may initiate a TIE as part of the TRE process to identify the cause(s) of toxicity. As guidance, the Discharger shall use the USEPA chronic manual, EPA/600/6-91/005F (Phase I), EPA/600/R-92/080 (Phase II), and EPA-600/R-92/081 (Phase III).
- (f)** As toxic substances are identified or characterized, the Discharger shall continue the TRE by determining the source(s) and evaluating alternative strategies for reducing or eliminating the substances from the discharge. All reasonable steps shall be taken to reduce toxicity to levels consistent with acute or chronic toxicity parameters.
- (g)** Many recommended TRE elements may be implemented in tandem with required efforts of source control, pollution prevention, and storm water control programs. TRE efforts should be coordinated with such efforts. To prevent duplication of efforts, evidence of complying with requirements of recommendations of such programs may be acceptable to comply with requirements of the TRE.
- (h)** The Regional Water Board recognizes that toxicity may be episodic and identification of a reduction of sources of toxicity may not be successful in all cases. Consideration of enforcement action by the Regional Water Board will be based in part on the Discharger's actions and efforts to identify and control or reduce sources of consistent toxicity.

3. Best Management Practices and Pollution Prevention

a. Pollutant Minimization Program (PMP)

The Discharger shall, as required by the Executive Officer, develop and conduct a PMP as further described below when there is evidence (e.g., sample results reported as detected, not quantified (DNQ) when the effluent limitation is less than the minimum detection limit (MDL), sample results from analytical methods more sensitive than those methods required by this Order, presence of whole effluent toxicity, health advisories for fish consumption, results of benthic or aquatic organism tissue sampling) that a priority pollutant is present in the effluent above an effluent limitation and either:

- i.** A sample result is reported as DNQ and the effluent limitation is less than the reporting limit (RL); or
 - ii.** A sample result is reported as ND and the effluent limitation is less than the MDL, using definitions described in Attachment A and reporting protocols described in MRP section XI.B.4.
- b.** The PMP shall include, but not be limited to, the following actions and submittals acceptable to the Regional Water Board:
 - i.** An annual review and semi-annual monitoring of potential sources of the reportable priority pollutant(s), which may include fish tissue monitoring and other bio-uptake sampling;
 - ii.** Quarterly monitoring for the reportable priority pollutant(s) in the influent to the wastewater treatment system;
 - iii.** Submittal of a control strategy designed to proceed toward the goal of maintaining concentrations of the reportable priority pollutant(s) in the effluent at or below the effluent limitation;
 - iv.** Implementation of appropriate cost-effective control measures for the reportable priority pollutant(s), consistent with the control strategy; and
 - v.** An annual status report that shall be submitted on March 1st to the Regional Water Board and shall include:
 - (a)** All PMP monitoring results for the previous year;
 - (b)** A list of potential sources of the reportable priority pollutant(s);

(c) A summary of all actions undertaken pursuant to the control strategy; and

(d) A description of actions to be taken in the following year.

4. Construction, Operation and Maintenance Specifications

- a. The Discharger shall at all times properly operate and maintain all facilities and systems of treatment and control (and related appurtenances) that are installed or used by the Discharger to achieve compliance with this Order. Proper operation and maintenance includes adequate laboratory quality control and appropriate quality assurance of procedures. This provision requires the operation of backup or auxiliary facilities or similar systems that are installed by the Discharger only when necessary to achieve compliance with the conditions of this Order. (40 CFR § 122.41(e).)
- b. The Discharger shall maintain an updated Operation and Maintenance (O&M) Manual for the Facility. The Discharger shall update the O&M Manual, as necessary, to conform to changes in operation and maintenance of the Facility. The O&M Manual shall be readily available to operating personnel onsite for review by state or federal inspectors. The O&M Manual shall include the following:
 - i. Description of the treatment facility, table of organization showing the number of employees, duties and qualifications and plant attendance schedules (daily, weekends and holidays, part-time, etc). The description should include documentation that the personnel are knowledgeable and qualified to operate the treatment facility so as to achieve the required level of treatment at all times.
 - ii. Detailed description of safe and effective operation and maintenance of treatment processes, process control instrumentation and equipment.
 - iii. Description of laboratory and quality assurance procedures.
 - iv. Process and equipment inspection and maintenance schedules.
 - v. Description of safeguards to assure that, should there be reduction, loss, or failure of electric power, the Discharger will be able to comply with requirements of this Order.
 - vi. Description of preventive (fail-safe) and contingency (response and cleanup) plans for controlling accidental discharges, and for minimizing the effect of such events. These plans shall identify the possible

sources (such as loading and storage areas, power outage, waste treatment unit failure, process equipment failure, tank and piping failure) of accidental discharges, untreated or partially treated waste bypass, and polluted drainage.

5. Special Provisions for Municipal Facilities (POTWs Only)

This section is not applicable.

6. Other Special Provisions

a. Storm Water

For the control of storm water discharge from the Facility, the Discharger shall seek authorization to discharge under and meet the requirements of the State Water Board's Water Quality Order No. 97-03-DWQ, NPDES General Permit No. CAS000001, *Waste Discharge Requirements for Discharges of Storm Water Associated with Industrial Activities Excluding Construction Activities* (or subsequent renewed versions of the General Permit).

b. Solids Disposal and Handling Requirements.

- i. By July 1, 2013, Bottom and Fly Ash generated at the Facility shall be stored in a Title 27 compliant area with an impermeable cover until it can be either disposed at a solid waste facility for which waste discharge requirements have been prescribed by a Regional Water Board or disposed in a manner approved by the Regional Water Board.
- ii. This Order does not authorize waste discharge to land except for the discharge of domestic wastes to an on-site sewage disposal system, which meets the limitations contained in the Basin Plan. Collected screenings, sludges, and other solids (including residual solids that collect in storage tanks) shall be disposed of at a legal solid waste disposal facility. Solid waste disposal sites used in California shall be regulated by waste discharge requirements prescribed by the Regional Water Board.

7. Compliance Schedules

This section is not applicable.

VII. COMPLIANCE DETERMINATION

Compliance with the effluent limitations contained in section IV of this Order will be determined as specified below.

A. General

Compliance with effluent limitations for priority pollutants shall be determined using sample reporting protocols defined in the MRP of this Order. For purposes of reporting and administrative enforcement by the Regional and State Water Boards, the Discharger shall be deemed out of compliance with effluent limitations if the concentration of the priority pollutant in the monitoring sample is greater than the effluent limitation and greater than or equal to the reporting level (RL).

B. Multiple Sample Data

When determining compliance with an AMEL for priority pollutants, and more than one sample result is available, the Discharger shall compute the arithmetic mean unless the data set contains one or more reported determinations of "Detected, but Not Quantified" (DNQ) or "Not Detected" (ND). In those cases, the Discharger shall compute the median in place of the arithmetic mean in accordance with the following procedure.

1. The data set shall be ranked from low to high, ranking the reported ND determinations lowest, DNQ determinations next, followed by quantified values (if any). The order of the individual ND or DNQ determinations is unimportant.
2. The median value of the data set shall be determined. If the data set has an odd number of data points, then the median is the middle value. If the data set has an even number of data points, then the median is the average of the two values around the middle unless one or both of the points are ND or DNQ, in which case the median value shall be the lower of the two data points where DNQ is lower than a value and ND is lower than DNQ.

C. Average Monthly Effluent Limitation (AMEL)

If the average (or when applicable, the median determined by subsection B above for multiple sample data) of daily discharges over a calendar month exceeds the AMEL for a given parameter, this will represent a single violation, though the Discharger will be considered out of compliance for each day of that month for that parameter (e.g., resulting in 31 days of non-compliance in a 31-day month). If only a single sample is taken during the calendar month and the analytical result for that sample exceeds the AMEL, the Discharger will be

considered out of compliance for that calendar month. The Discharger will only be considered out of compliance for days when the discharge occurs. For any one calendar month during which no sample (daily discharge) is taken, no compliance determination can be made for that calendar month.

D. Average Weekly Effluent Limitation (AWEL)

If the average (or when applicable, the median determined by subsection B above for multiple sample data) of daily discharges over a calendar week exceeds the AWEL for a given parameter, this will represent a single violation, though the Discharger will be considered out of compliance for each day of that week for that parameter, resulting in 7 days of non-compliance. If only a single sample is taken during the calendar week and the analytical result for that sample exceeds the AWEL, the Discharger will be considered out of compliance for that calendar week. The Discharger will only be considered out of compliance for days when the discharge occurs. For any one calendar week during which no sample (daily discharge) is taken, no compliance determination can be made for that calendar week.

E. Maximum Daily Effluent Limitation (MDEL)

If a daily discharge (or when applicable, the median determined by subsection B, above, for multiple sample data of a daily discharge) exceeds the MDEL for a given parameter, the Discharger will be considered out of compliance for that parameter for that 1 day only within the reporting period. For any 1 day during which no sample is taken, no compliance determination can be made for that day.

F. Instantaneous Minimum Effluent Limitation

If the analytical result of a single grab sample is lower than the instantaneous minimum effluent limitation for a parameter, the Discharger will be considered out of compliance for that parameter for that single sample. Non-compliance for each sample will be considered separately (e.g., the results of two grab samples taken within a calendar day that both are lower than the instantaneous minimum effluent limitation would result in two instances of non-compliance with the instantaneous minimum effluent limitation).

G. Mass Emission Limitation Calculation

Calculation of the mass emission rates in lbs/day shall be performed using the appropriate resulting concentration from either a grab sample or a flow weighted 24-hour composite sample multiplied by the respective instantaneous or 24-hour average combined low volume waste flow measured at M-010.

H. Instantaneous Maximum Effluent Limitation

If the analytical result of a single grab sample is higher than the instantaneous maximum effluent limitation for a parameter, the Discharger will be considered out of compliance for that parameter for that single sample. Non-compliance for each sample will be considered separately (e.g., the results of two grab samples taken within a calendar day that both exceed the instantaneous maximum effluent limitation would result in two instances of non-compliance with the instantaneous maximum effluent limitation).

ATTACHMENT A – DEFINITIONS

Acute Toxicity: This parameter shall be used to measure the acceptability of waters for supporting a healthy marine biota until improved methods are developed to evaluate biological response.

a. Acute Toxicity

Expressed in Toxic Units Acute (TUa)

$$\text{TUa} = \frac{100}{96\text{-hr LC } 50\%}$$

b. Lethal Concentration 50% (LC 50)

LC 50 (percent waste giving 50% survival of test organisms) shall be determined by static or continuous flow bioassay techniques using standard marine test species as specified in Appendix III, Chapter II of the Ocean Plan. If specific identifiable substances in wastewater can be demonstrated by the discharger as being rapidly rendered harmless upon discharge to the marine environment, but not as a result of dilution, the LC 50 may be determined after the test samples are adjusted to remove the influence of those substances.

When it is not possible to measure the 96-hour LC 50 due to greater than 50 percent survival of the test species in 100 percent waste, the toxicity concentration shall be calculated by the expression:

$$\text{TUa} = \frac{\log(100-S)}{1.7}$$

where:

S = percentage survival in 100% waste. If S>99, TUa shall be reported as zero.

Arithmetic Mean (μ): also called the average, is the sum of measured values divided by the number of samples. For ambient water concentrations, the arithmetic mean is calculated as follows:

Arithmetic mean = $\mu = \Sigma x / n$ where: Σx is the sum of the measured ambient water concentrations, and n is the number of samples.

Average Monthly Effluent Limitation (AMEL): the highest allowable average of daily discharges over a calendar month, calculated as the sum of all daily discharges measured during a calendar month divided by the number of daily discharges measured during that month.

Average Weekly Effluent Limitation (AWEL): the highest allowable average of daily discharges over a calendar week (Sunday through Saturday), calculated as the sum of all daily discharges measured during a calendar week divided by the number of daily discharges measured during that week.

Bioaccumulative: pollutants are those substances taken up by an organism from its surrounding medium through gill membranes, epithelial tissue, or from food and subsequently concentrated and retained in the body of the organism.

BMPs: means “best management practices.” Best management practices means schedules of activities, prohibitions of practices, maintenance procedures, and other management practices to prevent or reduce the pollution of “waters of the United States.” BMPs also include treatment requirements, operating procedures, and practices to control plant site runoff, spillage or leaks, sludge or waste disposal, or drainage from raw material storage.

Bottom Ash: the ash that drops out of the furnace gas stream in the furnace and in the economizer sections. Economizer ash is included when it is collected with bottom ash.

Carcinogenic: pollutants are substances that are known to cause cancer in living organisms.

Chemical Metal Cleaning Waste: any wastewater resulting from the cleaning of any metal process equipment with chemical compounds, including, but not limited to, boiler tube cleaning.

Chronic Toxicity: This parameter shall be used to measure the acceptability of waters for supporting a healthy marine biota until improved methods are developed to evaluate biological response.

a. Chronic Toxicity (TUc)

Expressed as Toxic Units Chronic (TUc)

$$\text{TUc} = \frac{100}{\text{NOEL}}$$

b. No Observed Effect Level (NOEL)

The NOEL is expressed as the maximum percent effluent or receiving water that causes no observable effect on a test organism, as determined by the result of a critical life stage toxicity test listed in Ocean Plan Appendix III, Table III-1.

Coefficient of Variation (CV): a measure of the data variability and is calculated as the estimated standard deviation divided by the arithmetic mean of the observed values.

Daily Discharge: Daily Discharge is defined as either: (1) the total mass of the constituent discharged over the calendar day (12:00 am through 11:59 pm) or any 24-hour period that reasonably represents a calendar day for purposes of sampling (as specified in the permit), for a constituent with limitations expressed in units of mass or; (2) the unweighted arithmetic mean measurement of the constituent over the day for a constituent with limitations expressed in other units of measurement (e.g., concentration).

The daily discharge may be determined by the analytical results of a composite sample taken over the course of one day (a calendar day or other 24-hour period defined as a day) or by the arithmetic mean of analytical results from one or more grab samples taken over the course of the day.

For composite sampling, if 1 day is defined as a 24-hour period other than a calendar day, the analytical result for the 24-hour period will be considered as the result for the calendar day in which the 24-hour period ends.

Detected, but Not Quantified (DNQ): those sample results less than the RL, but greater than or equal to the laboratory's MDL.

Dilution Credit: the amount of dilution granted to a discharge in the calculation of a water quality-based effluent limitation, based on the allowance of a specified mixing zone. It is calculated from the dilution ratio or determined through conducting a mixing zone study or modeling of the discharge and receiving water.

Effective Concentration (EC): a point estimate of the toxicant concentration that would cause an adverse effect on a quantal, “all or nothing,” response (such as death, immobilization, or serious incapacitation) in a given percent of the test organisms. If the effect is death or immobility, the term lethal concentration (LC) may be used. EC values may be calculated using point estimation techniques such as probit, logit, and Spearman-Kärber. EC25 is the concentration of toxicant (in percent effluent) that causes a response in 25 percent of the test organisms.

Effluent Concentration Allowance (ECA): a value derived from the water quality criterion/objective, dilution credit, and ambient background concentration that is used, in conjunction with the coefficient of variation for the effluent monitoring data, to calculate a long-term average (LTA) discharge concentration. The ECA has the same meaning as waste load allocation (WLA) as used in USEPA guidance (Technical Support Document For Water Quality-based Toxics Control, March 1991, second printing, EPA/505/2-90-001).

Enclosed Bays: indentations along the coast that enclose an area of oceanic water within distinct headlands or harbor works. Enclosed bays include all bays where the narrowest distance between the headlands or outermost harbor works is less than 75 percent of the greatest dimension of the enclosed portion of the bay. Enclosed bays include, but are not limited to, Humboldt Bay, Bodega Harbor, Tomales Bay, Drake’s Estero, San Francisco Bay, Morro Bay, Los Angeles-Long Beach Harbor, Upper and Lower Newport Bay, Mission Bay, and San Diego Bay. Enclosed bays do not include inland surface waters or ocean waters.

Estimated Chemical Concentration: the estimated chemical concentration that results from the confirmed detection of the substance by the analytical method below the ML value.

Estuaries: waters, including coastal lagoons, located at the mouths of streams that serve as areas of mixing for fresh and ocean waters. Coastal lagoons and mouths of streams that are temporarily separated from the ocean by sandbars shall be considered estuaries. Estuarine waters shall be considered to extend from a bay or the open ocean to a point upstream where there is no significant mixing of fresh water and seawater. Estuarine waters included, but are not limited to, the Sacramento-San Joaquin Delta, as defined in Water Code section 12220, Suisun Bay, Carquinez Strait downstream to the Carquinez Bridge, and appropriate areas of the Smith, Mad, Eel, Noyo, Russian, Klamath, San Diego, and Otay rivers. Estuaries do not include inland surface waters or ocean waters.

First runoff-producing storm event: The term “first runoff-producing storm event” means the first precipitation sequence following any log deck sprinkler use meeting all of the following criteria:

1. The precipitation causes overflow from the detention basin to Hensley Creek.
2. Required weekly and monthly analyses are reported for a sample of that overflow.

Fly Ash: the ash that is carried out of the furnace by the gas stream and collected by mechanical precipitators, electrostatic precipitators, and /or fabric filters. Economizer ash is included when it is collected with fly ash.

Free Available Chlorine: the value obtained using the amperometric titration method for free available chlorine described in Standard Methods for the Examination of Water and Wastewater, page 112, (13th edition).

Inhibition Concentration (IC): The IC25 is typically calculated as a percentage of effluent. It is the level at which the organisms exhibit 25 percent reduction in biological measurement such as reproduction or growth. It is calculated statistically and used in chronic toxicity testing.

Inland Surface Waters: all surface waters of the State that do not include the ocean, enclosed bays, or estuaries.

Instantaneous Maximum Effluent Limitation: the highest allowable value for any single grab sample or aliquot (i.e., each grab sample or aliquot is independently compared to the instantaneous maximum limitation).

Instantaneous Minimum Effluent Limitation: the lowest allowable value for any single grab sample or aliquot (i.e., each grab sample or aliquot is independently compared to the instantaneous minimum limitation).

Low Volume Wastes: The term low volume waste sources means, taken collectively as if from one source, wastewater from all sources except those for which specific limitations are otherwise established in 40 CFR 423. Low volume wastes sources include, but are not limited to: wastewaters from wet scrubber air pollution control systems, ion exchange water treatment systems, water treatment evaporator blowdown, laboratory and sampling streams, boiler blowdown, floor drains, cooling tower basin cleaning wastes, and recirculating house service water systems. Sanitary and air conditioning wastes are not included.

Maximum Daily Effluent Limitation (MDEL): the highest allowable daily discharge of a pollutant, over a calendar day (or 24-hour period). For pollutants with limitations expressed in units of mass, the daily discharge is calculated as the total mass of the pollutant discharged over the day. For pollutants with limitations expressed in other units of measurement, the daily discharge is calculated as the arithmetic mean measurement of the pollutant over the day.

Median: the middle measurement in a set of data. The median of a set of data is found by first arranging the measurements in order of magnitude (either increasing or decreasing order). If the number of measurements (n) is odd, then the median = $X_{(n+1)/2}$. If n is even, then the median = $(X_{n/2} + X_{(n/2)+1})/2$ (i.e., the midpoint between the $n/2$ and $n/2+1$).

Metal Cleaning Waste: any wastewater resulting from cleaning [with or without chemical cleaning compounds] any metal process equipment including, but not limited to, boiler tube cleaning, boiler fire side cleaning, and air preheater cleaning.

Method Detection Limit (MDL): the minimum concentration of a substance that can be measured and reported with 99 percent confidence that the analyte concentration is greater than zero, as defined in title 40 of the Code of Federal Regulations, Part 136, Attachment B, revised as of July 3, 1999.

Minimum Level (ML): the concentration at which the entire analytical system must give a recognizable signal and acceptable calibration point. The ML is the concentration in a sample that is equivalent to the concentration of the lowest calibration standard analyzed by a specific analytical procedure, assuming that all the method specified sample weights, volumes, and processing steps have been followed.

Mixing Zone: a limited volume of receiving water that is allocated for mixing with a wastewater discharge where water quality criteria can be exceeded without causing adverse effects to the overall water body.

Not Detected (ND): those sample results less than the laboratory's MDL.

Ocean Waters: the territorial marine waters of the State as defined by California law to the extent these waters are outside of enclosed bays, estuaries, and coastal lagoons. Discharges to ocean waters are regulated in accordance with the State Water Board's California Ocean Plan.

Persistent Pollutants: substances for which degradation or decomposition in the environment is nonexistent or very slow.

Pollutant Minimization Program (PMP): waste minimization and pollution prevention actions that include, but are not limited to, product substitution, waste stream recycling, alternative waste management methods, and education of the public and businesses. The goal of the PMP shall be to reduce all potential sources of a priority pollutant(s) through pollutant minimization (control) strategies, including pollution prevention measures as appropriate, to maintain the effluent concentration at or below the water quality-based effluent limitation. Pollution prevention measures may be particularly appropriate for persistent bioaccumulative priority pollutants where there is evidence

that beneficial uses are being impacted. The Regional Water Board may consider cost effectiveness when establishing the requirements of a PMP. The completion and implementation of a Pollution Prevention Plan, if required pursuant to Water Code section 13263.3(d), shall be considered to fulfill the PMP requirements.

Pollution Prevention: any action that causes a net reduction in the use or generation of a hazardous substance or other pollutant that is discharged into water and includes, but is not limited to, input change, operational improvement, production process change, and product reformulation (as defined in Water Code section 13263.3). Pollution prevention does not include actions that merely shift a pollutant in wastewater from one environmental medium to another environmental medium, unless clear environmental benefits of such an approach are identified to the satisfaction of the State or Regional Water Board.

Priority Pollutants: Those pollutants identified by the California Toxics Rule (CTR) at section 131.38.

Reporting Level (RL): the ML (and its associated analytical method) chosen by the Discharger for reporting and compliance determination from the MLs included in this Order. The MLs included in this Order correspond to approved analytical methods for reporting a sample result that are selected by the Regional Water Board either from Appendix 4 of the SIP in accordance with section 2.4.2 of the SIP or established in accordance with section 2.4.3 of the SIP. The ML is based on the proper application of method-based analytical procedures for sample preparation and the absence of any matrix interferences. Other factors may be applied to the ML depending on the specific sample preparation steps employed. For example, the treatment typically applied in cases where there are matrix-effects is to dilute the sample or sample aliquot by a factor of ten. In such cases, this additional factor must be applied to the ML in the computation of the RL.

Satellite Collection System: the portion, if any, of a sanitary sewer system owned or operated by a different public agency than the agency that owns and operates the wastewater treatment facility that a sanitary sewer system is tributary to.

Six-month Median Effluent Limitation: the highest allowable moving median of all daily discharges for any 180-day period.

Source of Drinking Water: any water designated as municipal or domestic supply (MUN) in a Regional Water Board Basin Plan.

Standard Deviation (σ): a measure of variability that is calculated as follows:

$$\sigma = \left(\frac{\sum[(x - \mu)^2]}{(n - 1)} \right)^{0.5}$$

where:

- x is the observed value;
- μ is the arithmetic mean of the observed values; and
- n is the number of samples.

Toxicity Reduction Evaluation (TRE): a study conducted in a step-wise process designed to identify the causative agents of effluent or ambient toxicity, isolate the sources of toxicity, evaluate the effectiveness of toxicity control options, and then confirm the reduction in toxicity. The first steps of the TRE consist of the collection of data relevant to the toxicity, including additional toxicity testing, and an evaluation of facility operations and maintenance practices, and best management practices. A Toxicity Identification Evaluation (TIE) may be required as part of the TRE, if appropriate. (A TIE is a set of procedures to identify the specific chemical(s) responsible for toxicity. These procedures are performed in three phases (characterization, identification, and confirmation) using aquatic organism toxicity tests.)

ATTACHMENT B – MAP

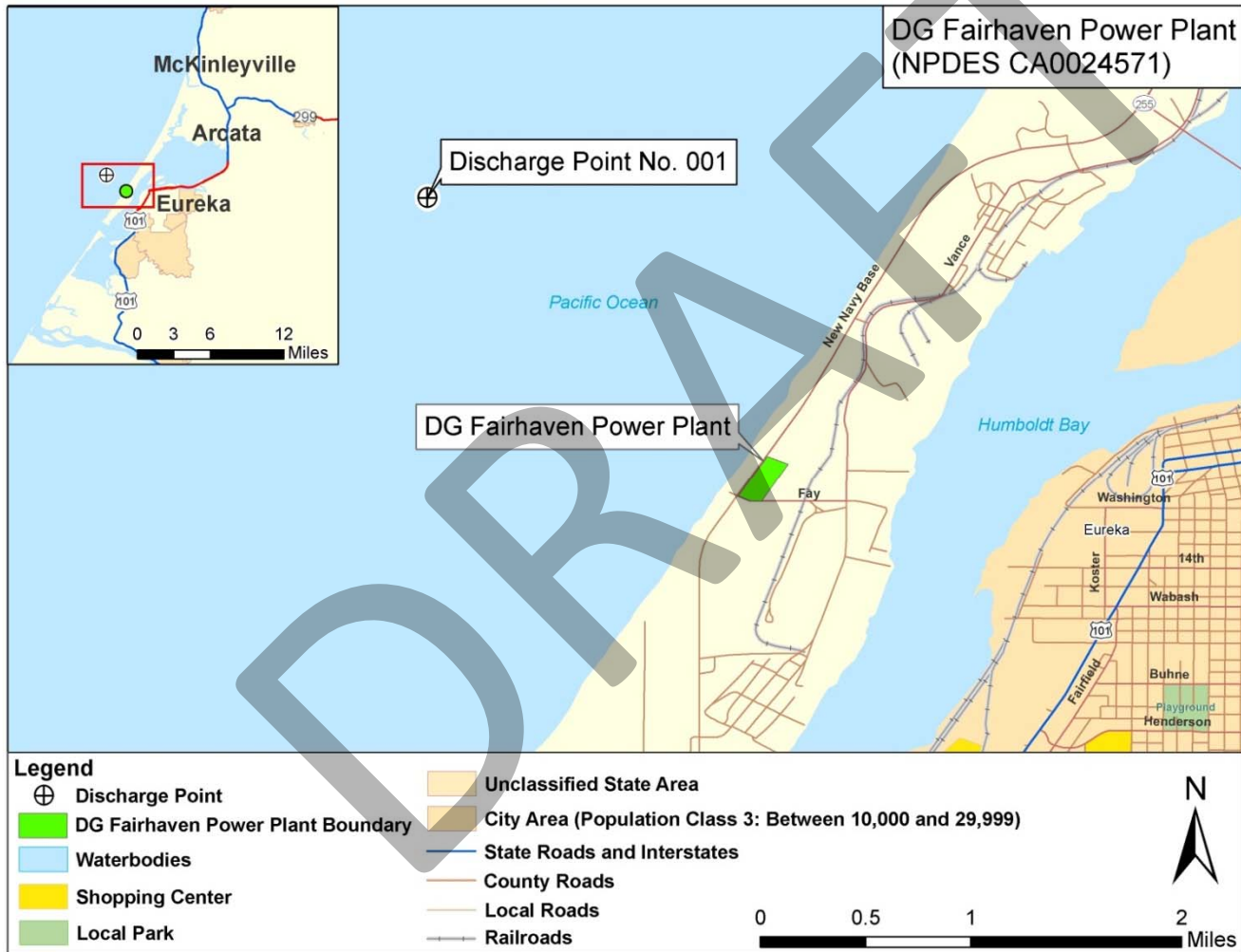

ATTACHMENT C – FLOW SCHEMATIC

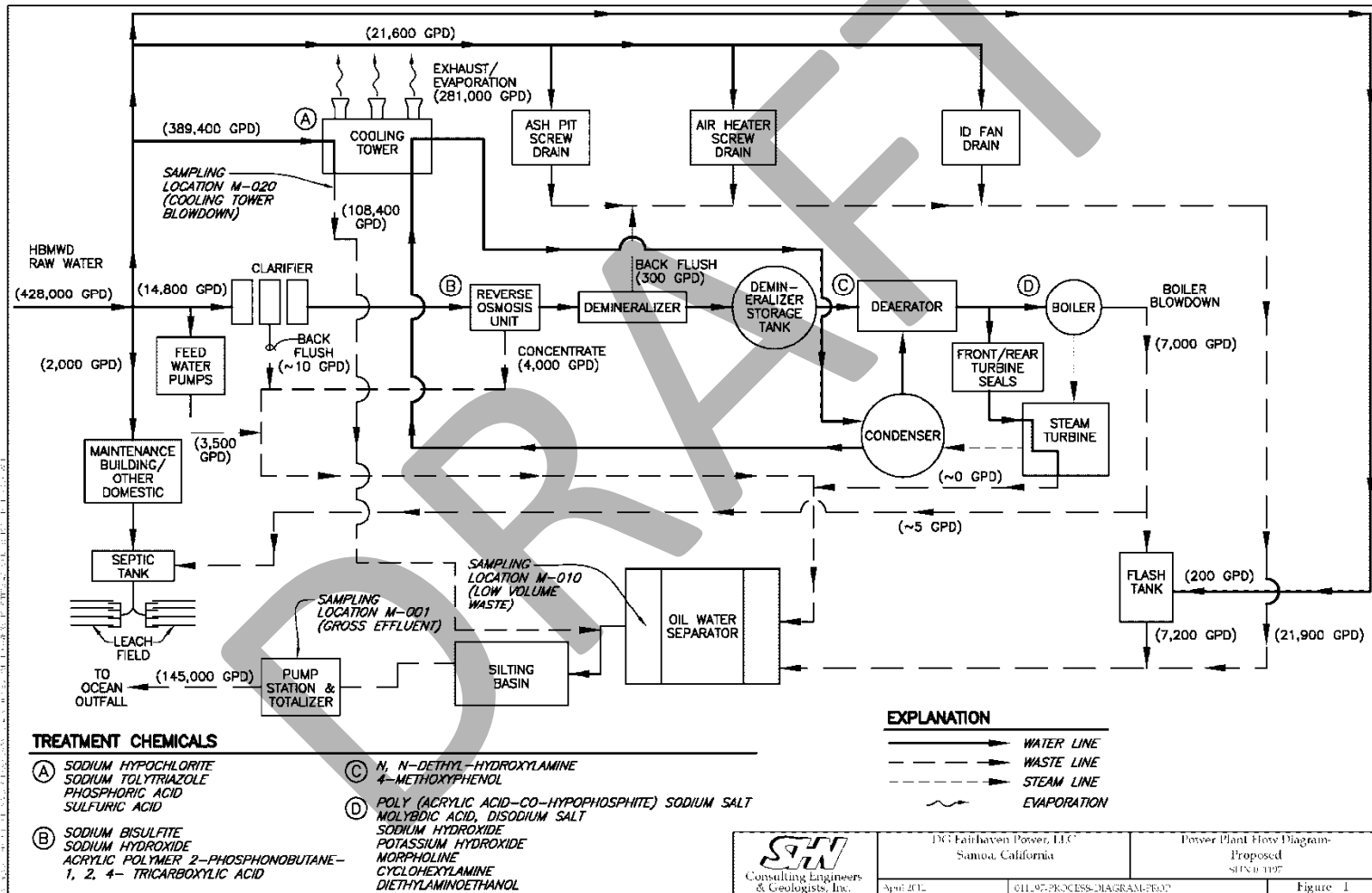

ATTACHMENT D – STANDARD PROVISIONS

I. STANDARD PROVISIONS – PERMIT COMPLIANCE

A. Duty to Comply

1. The Discharger must comply with all of the conditions of this Order. Any noncompliance constitutes a violation of the Clean Water Act (CWA) and the California Water Code and is grounds for enforcement action, for permit termination, revocation and reissuance, or modification; or denial of a permit renewal application. (40 C.F.R. § 122.41(a).)
2. The Discharger shall comply with effluent standards or prohibitions established under Section 307(a) of the CWA for toxic pollutants and with standards for sewage sludge use or disposal established under Section 405(d) of the CWA within the time provided in the regulations that establish these standards or prohibitions, even if this Order has not yet been modified to incorporate the requirement. (40 C.F.R. § 122.41(a)(1).)

B. Need to Halt or Reduce Activity Not a Defense

It shall not be a defense for a Discharger in an enforcement action that it would have been necessary to halt or reduce the permitted activity in order to maintain compliance with the conditions of this Order. (40 C.F.R. § 122.41(c).)

C. Duty to Mitigate

The Discharger shall take all reasonable steps to minimize or prevent any discharge or sludge use or disposal in violation of this Order that has a reasonable likelihood of adversely affecting human health or the environment. (40 C.F.R. § 122.41(d).)

D. Proper Operation and Maintenance

The Discharger shall at all times properly operate and maintain all facilities and systems of treatment and control (and related appurtenances) which are installed or used by the Discharger to achieve compliance with the conditions of this Order. Proper operation and maintenance also includes adequate laboratory controls and appropriate quality assurance procedures. This provision requires the operation of backup or auxiliary facilities or similar systems that are installed by a Discharger only when necessary to achieve compliance with the conditions of this Order. (40 C.F.R. § 122.41(e).)

E. Property Rights

1. This Order does not convey any property rights of any sort or any exclusive privileges. (40 C.F.R. § 122.41(g).)
2. The issuance of this Order does not authorize any injury to persons or property or invasion of other private rights, or any infringement of state or local law or regulations. (40 C.F.R. § 122.5(c).)

F. Inspection and Entry

The Discharger shall allow the Regional Water Board, State Water Board, United States Environmental Protection Agency (USEPA), and/or their authorized representatives (including an authorized contractor acting as their representative), upon the presentation of credentials and other documents, as may be required by law, to (40 C.F.R. § 122.41(i); Wat. Code, § 13383):

1. Enter upon the Discharger's premises where a regulated facility or activity is located or conducted, or where records are kept under the conditions of this Order (40 C.F.R. § 122.41(i)(1));
2. Have access to and copy, at reasonable times, any records that must be kept under the conditions of this Order (40 C.F.R. § 122.41(i)(2));
3. Inspect and photograph, at reasonable times, any facilities, equipment (including monitoring and control equipment), practices, or operations regulated or required under this Order (40 C.F.R. § 122.41(i)(3)); and
4. Sample or monitor, at reasonable times, for the purposes of assuring Order compliance or as otherwise authorized by the CWA or the Water Code, any substances or parameters at any location. (40 C.F.R. § 122.41(i)(4).)

G. Bypass

1. Definitions
 - a. "Bypass" means the intentional diversion of waste streams from any portion of a treatment facility. (40 C.F.R. § 122.41(m)(1)(i).)
 - b. "Severe property damage" means substantial physical damage to property, damage to the treatment facilities, which causes them to become inoperable, or substantial and permanent loss of natural resources that can reasonably be expected to occur in the absence of a bypass. Severe property damage does not mean economic loss caused by delays in production. (40 C.F.R. § 122.41(m)(1)(ii).)

- 2. Bypass not exceeding limitations.** The Discharger may allow any bypass to occur which does not cause exceedances of effluent limitations, but only if it is for essential maintenance to assure efficient operation. These bypasses are not subject to the provisions listed in Standard Provisions – Permit Compliance I.G.3, I.G.4, and I.G.5 below. (40 C.F.R. § 122.41(m)(2).)
- 3. Prohibition of bypass.** Bypass is prohibited, and the Regional Water Board may take enforcement action against a Discharger for bypass, unless (40 C.F.R. § 122.41(m)(4)(i)):
 - a.** Bypass was unavoidable to prevent loss of life, personal injury, or severe property damage (40 C.F.R. § 122.41(m)(4)(i)(A));
 - b.** There were no feasible alternatives to the bypass, such as the use of auxiliary treatment facilities, retention of untreated wastes, or maintenance during normal periods of equipment downtime. This condition is not satisfied if adequate back-up equipment should have been installed in the exercise of reasonable engineering judgment to prevent a bypass that occurred during normal periods of equipment downtime or preventive maintenance (40 C.F.R. § 122.41(m)(4)(i)(B)); and
 - c.** The Discharger submitted notice to the Regional Water Board as required under Standard Provisions – Permit Compliance I.G.6 below. (40 C.F.R. § 122.41(m)(4)(i)(C).)
- 4. Burden of Proof.** In any enforcement proceeding, the Discharger seeking to establish the bypass defense has the burden of proof.
- 5.** The Regional Water Board may approve an anticipated bypass, after considering its adverse effects, if the Regional Water Board determines that it will meet the three conditions listed in Standard Provisions – Permit Compliance I.G.3 above. (40 C.F.R. § 122.41(m)(4)(ii).)
- 6. Notice**
 - a.** Anticipated bypass. If the Discharger knows in advance of the need for a bypass, it shall submit a notice, if possible at least 10 days before the date of the bypass. (40 C.F.R. § 122.41(m)(3)(i).)
 - b.** Unanticipated bypass. The Discharger shall submit notice of an unanticipated bypass as required in Standard Provisions - Reporting V.E below (24-hour notice). (40 C.F.R. § 122.41(m)(3)(ii).)

H. Upset

Upset means an exceptional incident in which there is unintentional and temporary noncompliance with technology based permit effluent limitations because of factors beyond the reasonable control of the Discharger. An upset does not include noncompliance to the extent caused by operational error, improperly designed treatment facilities, inadequate treatment facilities, lack of preventive maintenance, or careless or improper operation. (40 C.F.R. § 122.41(n)(1).)

1. Effect of an upset. An upset constitutes an affirmative defense to an action brought for noncompliance with such technology based permit effluent limitations if the requirements of Standard Provisions – Permit Compliance I.H.2 below are met. No determination made during administrative review of claims that noncompliance was caused by upset, and before an action for noncompliance, is final administrative action subject to judicial review. (40 C.F.R. § 122.41(n)(2).)
2. Conditions necessary for a demonstration of upset. A Discharger who wishes to establish the affirmative defense of upset shall demonstrate, through properly signed, contemporaneous operating logs or other relevant evidence that (40 C.F.R. § 122.41(n)(3)):
 - a. An upset occurred and that the Discharger can identify the cause(s) of the upset (40 C.F.R. § 122.41(n)(3)(i));
 - b. The permitted facility was, at the time, being properly operated (40 C.F.R. § 122.41(n)(3)(ii));
 - c. The Discharger submitted notice of the upset as required in Standard Provisions – Reporting V.E.2.b below (24-hour notice) (40 C.F.R. § 122.41(n)(3)(iii)); and
 - d. The Discharger complied with any remedial measures required under Standard Provisions – Permit Compliance I.C above. (40 C.F.R. § 122.41(n)(3)(iv).)
3. Burden of proof. In any enforcement proceeding, the Discharger seeking to establish the occurrence of an upset has the burden of proof. (40 C.F.R. § 122.41(n)(4).)

II. STANDARD PROVISIONS – PERMIT ACTION

A. General

This Order may be modified, revoked and reissued, or terminated for cause. The filing of a request by the Discharger for modification, revocation and reissuance, or termination, or a notification of planned changes or anticipated noncompliance does not stay any Order condition. (40 C.F.R. § 122.41(f).)

B. Duty to Reapply

If the Discharger wishes to continue an activity regulated by this Order after the expiration date of this Order, the Discharger must apply for and obtain a new permit. (40 C.F.R. § 122.41(b).)

C. Transfers

This Order is not transferable to any person except after notice to the Regional Water Board. The Regional Water Board may require modification or revocation and reissuance of the Order to change the name of the Discharger and incorporate such other requirements as may be necessary under the CWA and the Water Code. (40 C.F.R. § 122.41(l)(3); § 122.61.)

III. STANDARD PROVISIONS – MONITORING

- A.** Samples and measurements taken for the purpose of monitoring shall be representative of the monitored activity. (40 C.F.R. § 122.41(j)(1).)
- B.** Monitoring results must be conducted according to test procedures under Part 136 or, in the case of sludge use or disposal, approved under Part 136 unless otherwise specified in Part 503 unless other test procedures have been specified in this Order. (40 C.F.R. § 122.41(j)(4); § 122.44(i)(1)(iv).)

IV. STANDARD PROVISIONS – RECORDS

- A.** Except for records of monitoring information required by this Order related to the Discharger's sewage sludge use and disposal activities, which shall be retained for a period of at least five years (or longer as required by Part 503), the Discharger shall retain records of all monitoring information, including all calibration and maintenance records and all original strip chart recordings for continuous monitoring instrumentation, copies of all reports required by this Order, and records of all data used to complete the application for this Order, for a period of at least three (3) years from the date of the sample, measurement, report or application. This period may be extended by request of the Regional Water Board Executive Officer at any time. (40 C.F.R. § 122.41(j)(2).)

B. Records of monitoring information shall include:

1. The date, exact place, and time of sampling or measurements (40 C.F.R. § 122.41(j)(3)(i));
1. The individual(s) who performed the sampling or measurements (40 C.F.R. § 122.41(j)(3)(ii));
2. The date(s) analyses were performed (40 C.F.R. § 122.41(j)(3)(iii));
3. The individual(s) who performed the analyses (40 C.F.R. § 122.41(j)(3)(iv));
4. The analytical techniques or methods used (40 C.F.R. § 122.41(j)(3)(v)); and
5. The results of such analyses. (40 C.F.R. § 122.41(j)(3)(vi).)

C. Claims of confidentiality for the following information will be denied (40 C.F.R. § 122.7(b)):

1. The name and address of any permit applicant or Discharger (40 C.F.R. § 122.7(b)(1)); and
2. Permit applications and attachments, permits and effluent data. (40 C.F.R. § 122.7(b)(2).)

V. STANDARD PROVISIONS – REPORTING

A. Duty to Provide Information

The Discharger shall furnish to the Regional Water Board, State Water Board, or USEPA within a reasonable time, any information which the Regional Water Board, State Water Board, or USEPA may request to determine whether cause exists for modifying, revoking and reissuing, or terminating this Order or to determine compliance with this Order. Upon request, the Discharger shall also furnish to the Regional Water Board, State Water Board, or USEPA copies of records required to be kept by this Order. (40 C.F.R. § 122.41(h); Wat. Code, § 13267.)

B. Signatory and Certification Requirements

1. All applications, reports, or information submitted to the Regional Water Board, State Water Board, and/or USEPA shall be signed and certified in accordance with Standard Provisions – Reporting V.B.2, V.B.3, V.B.4, and V.B.5 below. (40 C.F.R. § 122.41(k).)

- 2.** All permit applications shall be signed by either a principal executive officer or ranking elected official. For purposes of this provision, a principal executive officer of a federal agency includes: (i) the chief executive officer of the agency, or (ii) a senior executive officer having responsibility for the overall operations of a principal geographic unit of the agency (e.g., Regional Administrators of USEPA). (40 C.F.R. § 122.22(a)(3).)
- 3.** All reports required by this Order and other information requested by the Regional Water Board, State Water Board, or USEPA shall be signed by a person described in Standard Provisions – Reporting V.B.2 above, or by a duly authorized representative of that person. A person is a duly authorized representative only if:

 - a.** The authorization is made in writing by a person described in Standard Provisions – Reporting V.B.2 above (40 C.F.R. § 122.22(b)(1));
 - b.** All permit applications shall be signed by a responsible corporate officer. For the purpose of this section, a responsible corporate officer means: (i) A president, secretary, treasurer, or vice-president of the corporation in charge of a principal business function, or any other person who performs similar policy- or decision-making functions for the corporation, or (ii) the manager of one or more manufacturing, production, or operating facilities, provided, the manager is authorized to make management decisions which govern the operation of the regulated facility including having the explicit or implicit duty of making major capital investment recommendations, and initiating and directing other comprehensive measures to assure long term environmental compliance with environmental laws and regulations; the manager can ensure that the necessary systems are established or actions taken to gather complete and accurate information for permit application requirements; and where authority to sign documents has been assigned or delegated to the manager in accordance with corporate procedures. (40 CFR 122.22(a)(1).)
 - c.** The written authorization is submitted to the Regional Water Board and State Water Board. (40 C.F.R. § 122.22(b)(3).)
- 4.** If an authorization under Standard Provisions – Reporting V.B.3 above is no longer accurate because a different individual or position has responsibility for the overall operation of the facility, a new authorization satisfying the requirements of Standard Provisions – Reporting V.B.3 above must be submitted to the Regional Water Board and State Water Board prior to or together with any reports, information, or applications, to be signed by an authorized representative. (40 C.F.R. § 122.22(c).)

5. Any person signing a document under Standard Provisions – Reporting V.B.2 or V.B.3 above shall make the following certification:

“I certify under penalty of law that this document and all attachments were prepared under my direction or supervision in accordance with a system designed to assure that qualified personnel properly gather and evaluate the information submitted. Based on my inquiry of the person or persons who manage the system or those persons directly responsible for gathering the information, the information submitted is, to the best of my knowledge and belief, true, accurate, and complete. I am aware that there are significant penalties for submitting false information, including the possibility of fine and imprisonment for knowing violations.” (40 C.F.R. § 122.22(d).)

C. Monitoring Reports

1. Monitoring results shall be reported at the intervals specified in the Monitoring and Reporting Program (Attachment E) in this Order. (40 C.F.R. § 122.22(l)(4).)
2. Monitoring results must be reported on a Discharge Monitoring Report (DMR) form or forms provided or specified by the Regional Water Board or State Water Board for reporting results of monitoring of sludge use or disposal practices. (40 C.F.R. § 122.41(l)(4)(i).)
3. If the Discharger monitors any pollutant more frequently than required by this Order using test procedures approved under Part 136 or, in the case of sludge use or disposal, approved under Part 136 unless otherwise specified in Part 503, or as specified in this Order, the results of this monitoring shall be included in the calculation and reporting of the data submitted in the DMR or sludge reporting form specified by the Regional Water Board. (40 C.F.R. § 122.41(l)(4)(ii).)
4. Calculations for all limitations, which require averaging of measurements, shall utilize an arithmetic mean unless otherwise specified in this Order. (40 C.F.R. § 122.41(l)(4)(iii).)

D. Compliance Schedules

Reports of compliance or noncompliance with, or any progress reports on, interim and final requirements contained in any compliance schedule of this Order, shall be submitted no later than 14 days following each schedule date. (40 C.F.R. § 122.41(l)(5).)

E. Twenty-Four Hour Reporting

1. The Discharger shall report any noncompliance that may endanger health or the environment. Any information shall be provided orally within 24 hours from the time the Discharger becomes aware of the circumstances. A written submission shall also be provided within five (5) days of the time the Discharger becomes aware of the circumstances. The written submission shall contain a description of the noncompliance and its cause; the period of noncompliance, including exact dates and times, and if the noncompliance has not been corrected, the anticipated time it is expected to continue; and steps taken or planned to reduce, eliminate, and prevent reoccurrence of the noncompliance. (40 C.F.R. § 122.41(l)(6)(i))
2. The following shall be included as information that must be reported within 24 hours under this paragraph (40 C.F.R. § 122.41(l)(6)(ii)):
 - a. Any unanticipated bypass that exceeds any effluent limitation in this Order. (40 C.F.R. § 122.41(l)(6)(ii)(A).)
 - b. Any upset that exceeds any effluent limitation in this Order. (40 C.F.R. § 122.41(l)(6)(ii)(B))
 - c. Violation of a maximum daily discharge limitation for any of the pollutants listed in this Order to be reported within 24 hours [40 CFR § 122.41(l)(6)(ii)(C)]
 - d. The Regional Water Board may waive the above-required written report under this provision on a case-by-case basis if an oral report has been received within 24 hours. (40 C.F.R. § 122.41(l)(6)(iii).)

F. Planned Changes

The Discharger shall give notice to the Regional Water Board as soon as possible of any planned physical alterations or additions to the permitted facility. Notice is required under this provision only when (40 C.F.R. § 122.41(l)(1)):

1. The alteration or addition to a permitted facility may meet one of the criteria for determining whether a facility is a new source in section 122.29(b) (40 C.F.R. § 122.41(l)(1)(i)); or
2. The alteration or addition could significantly change the nature or increase the quantity of pollutants discharged. This notification applies to pollutants that are subject neither to effluent limitations in this Order nor to notification requirements under 40 CFR 122.42(a)(1) (see Additional Provisions— Notification Levels VII.A.1). (40 CFR 122.41(l)(1)(ii).)

3. The alteration or addition results in a significant change in the Discharger's sludge use or disposal practices, and such alteration, addition, or change may justify the application of permit conditions that are different from or absent in the existing permit, including notification of additional use or disposal sites not reported during the permit application process or not reported pursuant to an approved land application plan. (40 C.F.R. § 122.41(l)(1)(iii).)

G. Anticipated Noncompliance

The Discharger shall give advance notice to the Regional Water Board or State Water Board of any planned changes in the permitted facility or activity that may result in noncompliance with General Order requirements. (40 C.F.R. § 122.41(l)(2).)

H. Other Noncompliance

The Discharger shall report all instances of noncompliance not reported under Standard Provisions – Reporting V.C, V.D, and V.E above at the time monitoring reports are submitted. The reports shall contain the information listed in Standard Provision – Reporting V.E above. (40 C.F.R. § 122.41(l)(7).)

I. Other Information

When the Discharger becomes aware that it failed to submit any relevant facts in a permit application, or submitted incorrect information in a permit application or in any report to the Regional Water Board, State Water Board, or USEPA, the Discharger shall promptly submit such facts or information. (40 C.F.R. § 122.41(l)(8).)

VI. STANDARD PROVISIONS – ENFORCEMENT

- A. The Regional Water Board is authorized to enforce the terms of this permit under several provisions of the Water Code, including, but not limited to, sections 13385, 13386, and 13387

VII. ADDITIONAL PROVISIONS – NOTIFICATION LEVELS

A. Non-Municipal Facilities

Existing manufacturing, commercial, mining, and silvicultural Dischargers shall notify the Regional Water Board as soon as they know or have reason to believe (40 CFR 122.42(a)):

1. That any activity has occurred or will occur that would result in the discharge, on a routine or frequent basis, of any toxic pollutant that is not limited in this

Order, if that discharge will exceed the highest of the following "notification levels" (40 CFR 122.42(a)(1)):

- a. 100 micrograms per liter ($\mu\text{g/L}$) (40 CFR 122.42(a)(1)(i));
 - b. 200 $\mu\text{g/L}$ for acrolein and acrylonitrile; 500 $\mu\text{g/L}$ for 2,4-dinitrophenol and 2-methyl-4,6-dinitrophenol; and 1 milligram per liter (mg/L) for antimony (40 CFR 122.42(a)(1)(ii));
 - c. Five (5) times the maximum concentration value reported for that pollutant in the Report of Waste Discharge (40 CFR 122.42(a)(1)(iii)); or
 - d. The level established by the Regional Water Board in accordance with 40 CFR 122.44(f). (40 CFR 122.42(a)(1)(iv).)
2. That any activity has occurred or will occur that would result in the discharge, on a non-routine or infrequent basis, of any toxic pollutant that is not limited in this Order, if that discharge will exceed the highest of the following "notification levels" (40 CFR 122.42(a)(2)):
- a. 500 micrograms per liter ($\mu\text{g/L}$) (40 CFR 122.42(a)(2)(i));
 - b. 1 milligram per liter (mg/L) for antimony (40 CFR 122.42(a)(2)(ii));
 - c. Ten (10) times the maximum concentration value reported for that pollutant in the Report of Waste Discharge (40 CFR 122.42(a)(2)(iii)); or
 - d. The level established by the Regional Water Board in accordance with section 122.44(f). (40 CFR 122.42(a)(2)(iv).)

ATTACHMENT E – MONITORING AND REPORTING PROGRAM

Table of Contents

| | | |
|-------|--|------|
| I. | General Monitoring Provisions | E-2 |
| II. | Monitoring Locations | E-3 |
| III. | Effluent Monitoring Requirements | E-3 |
| IV. | Whole Effluent Toxicity Testing Requirements | E-6 |
| V. | Land Discharge Monitoring Requirements | E-12 |
| VI. | Reclamation Monitoring Requirements | E-12 |
| VII. | Receiving Water Monitoring Requirements | E-12 |
| VIII. | Other Monitoring Requirements | E-12 |
| IX. | Reporting Requirements | E-12 |
| | A. General Monitoring and Reporting Requirements | E-12 |
| | B. Self Monitoring Reports (SMRs) | E-13 |
| | C. Other Reports | E-15 |
| | D. Spills and Overflows Notification | E-16 |
| | E. Discharge Monitoring Reports (DMRs) | E-18 |

List of Tables

| | | |
|------------|--|------|
| Table E-1. | Monitoring Station Locations | E-3 |
| Table E-2. | Gross Effluent Monitoring – Location M-001 | E-4 |
| Table E-3. | Low Volume Waste Monitoring – Location M-010 | E-5 |
| Table E-4. | Cooling Tower Blowdown Monitoring – Location M-020 | E-5 |
| Table E-5. | Approved Tests – Chronic Toxicity | E-7 |
| Table E-6. | Monitoring Periods and Reporting Schedule | E-13 |

ATTACHMENT E – MONITORING AND REPORTING PROGRAM (MRP)

Title 40 of the Code of Federal Regulations section 122.48 (section 122.48) requires that all National Pollutant Discharge Elimination System (NPDES) permits specify monitoring and reporting requirements. California Water Code (Water Code) Sections 13267 and 13383 also authorize the Regional Water Quality Control Board (Regional Water Board) to require technical and monitoring reports. This MRP establishes monitoring and reporting requirements, which implement the federal and California regulations.

I. GENERAL MONITORING PROVISIONS

- A.** Composite samples may be taken by a proportional sampling device approved by the Executive Officer or by grab samples composited in proportion to flow. In compositing grab samples, the sampling interval shall not exceed 1 hour.
- B.** If the Discharger monitors any pollutant more frequently than required by this Order, using test procedures approved by 40 CFR Part 136, or as specified in this Order, the results of this monitoring shall be included in the calculation and reporting of the data submitted in the monthly and annual discharger monitoring reports.
- C.** Laboratories analyzing monitoring samples shall be certified by the California Department of Public Health (DPH; formerly the Department of Health Services), in accordance with the provision of Water Code section 13176, and must include quality assurance/quality control data with their reports.
- D.** The Discharger shall develop, maintain and adhere to a standard operating procedure that follows the appropriate Standard Method for any sampling analysis performed by the Discharger for compliance with this order or MRP. Common examples of such analyses include flow, pH, chlorine residual and dissolved oxygen because the holding times for these analyses are sufficiently short that Dischargers often perform the analyses on-site or in the field. Any standard operating procedure kept for such analyses shall include, at a minimum:
 - 1.** Instrument calibration protocols and a log of such calibrations;
 - 2.** Staff training procedures and a log of such trainings; and
 - 3.** A procedure for taking multiple readings of the same sample for data quality assurance.
- E.** Compliance and reasonable potential monitoring analyses shall be conducted using commercially available and reasonably achievable detection limits that are lower than the applicable effluent limitation. If no minimum level (ML) value is

below the effluent limitation, the lowest ML shall be selected as the reporting level (RL).

II. MONITORING LOCATIONS

The Discharger shall establish the following monitoring locations to demonstrate compliance with the effluent limitations, discharge specifications, and other requirements in this Order:

Table E-1. Monitoring Station Locations

| Discharge Point Name | Monitoring Location Name | Monitoring Location Description |
|----------------------|--------------------------|--|
| 001 | M-001 | Process Water Gross Effluent combined discharge (including: Low Volume Wastes and Cooling Tower Blowdown) following all treatment processes prior to contact with receiving water (Pacific Ocean). |
| 010 | M-010 | Combined low volume wastewaters (screw and bearing cooling process water, boiler blowdown, demineralizer back flush, and reverse osmosis concentrate) prior to commingling with cooling tower blowdown. Low volume wastes may be monitored as separate waste streams or as a combined low volume waste stream. If measured as separate waste streams, a flow weighted aliquate, consisting of all low volume waste stream contributions, shall be used to determine compliance with applicable effluent limitations. |
| 020 | M-020 | Cooling tower blowdown process wastewater prior to commingling with low volume wastewaters. |
| -- | M-030 | Internal monitoring point for metal cleaning wastes |
| -- | M-040 | Internal monitoring point for bottom ash wash water |

III. EFFLUENT MONITORING REQUIREMENTS

A. Monitoring Location M-001

The Discharger shall monitor at Monitoring Location M-001 as follows when process water is being discharged to the Pacific Ocean:

Table E-2. Gross Effluent Monitoring – Location M-001

| Parameter | Units | Sample Type | Minimum Sampling Frequency | Required Analytical Test Method ^{1,2} |
|-------------------------------------|-----------|---------------------------------|----------------------------|--|
| Flow (Instantaneous) | MGD | Meter | Monthly ³ | -- |
| Flow (24-hour average) | MGD | Meter | Continuous | -- |
| Flow (Monthly Average) | MGD | Meter | Continuous | -- |
| Copper, Total Recoverable | µg/L | Flow weighted 24-hour Composite | Monthly | 40 CFR Part 136 |
| | µg/L | Grab | Monthly | Part 136 |
| | lbs/day | Calculation ⁴ | Monthly | Calculation |
| | lbs/day | Calculation ⁵ | Monthly | Calculation |
| Chromium, Total Recoverable | µg/L | Grab | Monthly ⁶ | Part 136 |
| Zinc, Total Recoverable | µg/L | Grab | Monthly ⁶ | Part 136 |
| pH | std units | Grab | Monthly | Part 136 |
| All Table B Pollutants ⁷ | µg/L | Grab | Once every five years | Std Methods |
| Acute Toxicity | TUa | Grab | Semi-annually | See Acute Toxicity Monitoring Requirements Section IV. |
| Chronic Toxicity | TUc | Grab | Quarterly ⁸ | See Chronic Toxicity |

¹ Minimum levels and monitoring procedures shall comply with Appendix II and Appendix III of the California Ocean Plan. Detection limits shall enable compliance determination with the respective effluent limitation or, if this is unachievable, the lowest minimum level in Appendix II of the California Ocean Plan shall be used.

² In accordance with the current edition of *Standard Methods (std method) for the Examination of Water and Wastewater* (American Public Health Administration) or current test procedures specified in section Part 136.

³ The time of the reported instantaneous flow shall coincide with the grab sample time of the Total Recoverable Copper at M-001.

⁴ Calculation of the mass emission rates in lbs/day shall be performed using the resulting concentration from a grab sample multiplied by the instantaneous flow at M-001.

⁵ Calculation of the mass emission rates in lbs/day shall be performed using the resulting concentration from a flow weighted 24-hour composite sample multiplied by the 24-hour average flow at M-001.

⁶ The minimum sampling frequency for this constituent may be reduced to quarterly upon six consecutive monitoring results in compliance with the respective effluent limitation, however, if at any time monitoring results in an exceedance of the respective effluent limitation, the minimum sampling frequency shall be reduced to monthly.

⁷ Pollutants specified in Table B of Section II.D.7 of the California Ocean Plan.

| Parameter | Units | Sample Type | Minimum Sampling Frequency | Required Analytical Test Method ^{1,2} |
|-----------|-------|-------------|----------------------------|--|
| | | | | Monitoring Requirements Section IV. |

B. Monitoring Location M-010

The Discharger shall monitor process water at all low volume waste streams as follows:

Table E-3. Low Volume Waste Monitoring – Location M-010

| Parameter | Units | Sample Type | Minimum Sampling Frequency | Required Analytical Test Method ^{1,2} |
|------------------------|-------|-------------|----------------------------|--|
| Flow (Instantaneous) | MGD | Meter | Monthly ⁹ | -- |
| Flow (24-hour average) | MGD | Meter | Continuous | -- |
| Flow (Monthly Average) | MGD | Meter | Continuous | -- |
| Total Suspended Solids | mg/L | Grab | Monthly ⁶ | Std Method 2540D |
| Oil and Grease | mg/L | Grab | Monthly ⁶ | Std Method 5520 |
| pH | s.u. | Grab | Monthly | 40 CFR Part 136 |

Table E-4. Cooling Tower Blowdown Monitoring – Location M-020

| Parameter | Units | Sample Type | Minimum Sampling Frequency | Required Analytical Test Method ^{1,2} |
|-----------------------------|-------|-------------|----------------------------|--|
| Flow (Mean) ⁴ | MGD | Meter | Continuous | -- |
| Free Available Chlorine | mg/L | Grab | Monthly | Std Method 4500-Cl D. |
| Total Residual Chlorine | mg/L | Grab | Monthly | Std Method 4500-Cl D. |
| Chromium, Total Recoverable | mg/L | Grab | Monthly ⁶ | 40 CFR Part 136 |
| Zinc, Total Recoverable | mg/L | Grab | Monthly ⁶ | 40 CFR Part 136 |

⁸ The Discharger may reduce the monitoring frequency for chronic toxicity from quarterly to semi-annually after six consecutive quarterly monitoring results demonstrating compliance with the chronic toxicity effluent limitation. If an exceedance of the chronic toxicity effluent limitation is detected, monitoring shall return to quarterly for the remainder of the permit term.

⁹ The time of the instantaneous flow shall coincide with the grab sample time of the Total Recoverable Copper at M-010.

| Parameter | Units | Sample Type | Minimum Sampling Frequency | Required Analytical Test Method ^{1,2} |
|-----------------------------------|-------|-------------|-----------------------------|--|
| Flow (Mean) ⁴ | MGD | Meter | Continuous | -- |
| Priority Pollutants ¹⁰ | µg/L | Grab | Semi-Annually ¹¹ | Std Methods |
| pH | s.u. | Grab | Monthly | 40 CFR Part 136 |

IV. WHOLE EFFLUENT TOXICITY TESTING REQUIREMENTS

A. Acute Toxicity Testing

The Discharger shall conduct acute whole effluent toxicity (WET) testing to determine compliance with the effluent limitation for acute toxicity established by section IV.A.1.a of the Order.

- 1. Test Frequency.** The Discharger shall conduct acute WET testing in accordance with the schedule established by this MRP, as summarized in Table E-2, above, when discharging to the Pacific Ocean.
- 2. Sample Type.** For 96-hour static renewal or 96-hour static non-renewal testing, the effluent samples shall be 24-hour composite samples representative of the volume and quality of the discharge from the Facility, collected at Monitoring Location M-001. For toxicity tests requiring renewals, 24-hour composite samples collected on consecutive days are required.
- 3. Test Species.** Test species for acute WET testing shall be conducted using an approved test, and test species, as described by Table III-1 of the Ocean Plan and presented below in Table E-5. Initial testing for the first suite of tests, shall be conducted with a vertebrate, an invertebrate, and a plant species, and thereafter, monitoring can be reduced to the most sensitive species. At least once every 5 years, the Discharger shall re-screen with the two species described above and continue routine monitoring with the most sensitive species.

B. Chronic Toxicity Testing

The Discharger shall conduct quarterly chronic toxicity testing to demonstrate compliance with the chronic toxicity effluent limitation contained in the Order for Discharge Point 001, with compliance determined at Monitoring Location

¹⁰ Applies to those pollutants contained in chemicals added for cooling tower maintenance except Total Chromium and Total Zinc. Priority pollutants to be monitored shall be identified according to the requirements contained in section IX.A of the MRP.

¹¹ Increased monitoring frequency will apply if chemicals used in process make-up water change between scheduled sampling periods

M-001. The monitoring frequency may be reduced to semiannually following 3 years of consecutive quarterly monitoring, demonstrating compliance with the applicable effluent limitation. However, if chronic toxicity is detected within the effluent exceeding the applicable effluent limitation, the monitoring frequency shall return to quarterly for the duration of the permit term. The Discharger shall meet the following chronic toxicity testing requirements:

1. **Test Frequency.** The Discharger shall conduct chronic WET testing in accordance with the schedule established by this MRP, as summarized in Table E-2, above, when discharging to the Pacific Ocean.
2. **Sample Type.** Effluent samples from Monitoring Locations M-001 shall be grab samples that are representative of the volume and quality of the discharge from the Facility. For toxicity tests conducted on-site and requiring renewals, grab samples collected on consecutive days are required. When tests are conducted off-site, a minimum of three samples shall be collected, in accordance with USEPA test methods.
3. **Test Species.** Critical life stage bioassay testing shall be conducted using an approved test, and test species, as described by Table III-1 of the Ocean Plan and presented below. Initial testing for the first suite of tests, shall be conducted with a vertebrate, an invertebrate, and a plant species, and thereafter, monitoring can be reduced to the most sensitive species. At least once every five years, the Discharger shall rescreen once with the three species listed above, and continue to monitor with the most sensitive species.

Table E-5. Approved Tests – Chronic Toxicity

| Species | Test | Tier ¹ | Reference ² |
|---|--|-------------------|------------------------|
| Giant kelp, <i>Macrocystis pyrifera</i> | percent germination; germ tube length | 1 | a, c |
| Red abalone, <i>Haliotis rufescens</i> | abnormal shell development | 1 | a, c |
| Oyster, <i>Crassostrea gigas</i> ; mussels, <i>Mytilus spp.</i> | abnormal shell development; percent survival | 1 | a, c |
| Urchin, <i>Strongylocentrotus purpuratus</i> ; sand dollar, <i>Dendraster excentricus</i> | percent normal development | 1 | a, c |
| Urchin, <i>Strongylocentrotus purpuratus</i> ; sand dollar, <i>Dendraster excentricus</i> | percent fertilization | 1 | a, c |
| Shrimp, <i>Homesimysis costata</i> | percent survival; growth | 1 | a, c |
| Shrimp, <i>Mysidopsis bahia</i> | percent survival; fecundity | 2 | b, d |
| Topsmelt, <i>Atherinops affinis</i> | larval growth rate; percent survival | 1 | a, c |
| Silverside, <i>Menidia beryllina</i> | larval growth rate; percent survival | 2 | b, d |

¹ First tier methods are preferred for compliance monitoring. If first tier organisms are not available, the Discharger can use a second tier test method following approval by the Regional Water Board.

² Protocol References:

- a. Chapman, G.A., D.L. Denton, and J.M. Lazorchak. 1995. *Short-term Methods for Estimating the Chronic Toxicity of Effluents and Receiving Waters to West Coast Marine and Estuarine Organisms*. U.S. EPA Report No. EPA/600/R-95/136.
- b. Klemm, D.J., G.E. Morrison, T.J. Norberg-King, W.J. Peltier, and M.A. Heber. 1994. *Short-term Methods for Estimating the Chronic Toxicity of Effluents and Receiving Water to Marine and Estuarine Organisms*. U.S. EPA Report No. EPA-600-4-91-003.
- c. SWRCB 1996. *Procedures Manual for Conducting Toxicity Tests Developed by the Marine Bioassay Project*. 96-1WQ.
- d. Weber, C.I., W.B. Horning, I.I., D.J. Klemm, T.W. Nieheisel, P.A. Lewis, E.L. Robinson, J. Menkedick and F. Kessler (eds). 1998. *Short-term Methods for Estimating the Chronic Toxicity of Effluents and Receiving Waters to Marine and Estuarine Organisms*. EPA/600/4-87/028. National Information Service, Springfield, VA.

4. Test Methods. The presence of chronic toxicity shall be estimated as specified in USEPA's Short-Term Methods for Estimating the Chronic Toxicity of Effluents and Receiving Water to West Coast Marine and Estuarine Organisms (USEPA Report No. EPA/600/R-95/136, or subsequent editions), Short-Term Methods for Estimating the Chronic Toxicity of Effluents and Receiving Water to Marine and Estuarine Organisms (USEPA Report No. EPA-821-R-02-014 or subsequent editions), or other methods approved by the Executive Officer.

5. Test Dilutions. For this discharge, a mixing zone or dilution allowance is authorized. The series shall consist of the following dilution series: 3.4, 1.75, 0.87, 0.45, and 0.25 percent, and a control. Control and dilution water shall be receiving water collected at an appropriate location beyond the influence of the discharge. Laboratory water may be substituted for receiving water, as described in the USEPA test methods manual, upon approval by the Executive Officer. If the dilution water used is different from the culture water, a second control using culture water shall be used.

6. Reference Toxicant. If organisms are not cultured in-house, concurrent testing with a reference toxicant shall be conducted. Where organisms are cultured in-house, monthly reference toxicant testing is sufficient. Reference toxicant tests also shall be conducted using the same test conditions as the effluent toxicity tests (e.g., same test duration, etc).

7. Test Failure. If either the reference toxicant test or the chronic toxicity test does not meet all test acceptability criteria, as specified in the test method, the Discharger shall re-sample and re-test as soon as possible, not to exceed 7 days following notification of test failure.

- 8. Notification.** The Discharger shall notify the Regional Water Board in writing 14 days after the receipt of test results, which indicate the exceedance of the water quality objective for chronic toxicity. The notification will describe actions the Discharger has taken or will take to investigate and correct the cause(s) of toxicity. It may also include a status report on any actions required by this Order, with a schedule for actions not yet completed. If no actions have been taken, the reasons shall be provided.
- 9. Accelerated Monitoring Requirements.** If the result of any chronic toxicity test exceeds the effluent limitation of 115 TUc, and the testing meets all test acceptability criteria, the Discharger shall initiate accelerated monitoring. Accelerated monitoring shall consist of four additional samples, with one test conducted approximately every week over a 4 week period. Testing shall commence within 14 days of receipt of initial sample results which indicated an exceedance of the chronic toxicity limitations (115 TUc). If the discharge will cease before the additional samples can be collected, the Discharger shall contact the Executive Officer within 21 days with a plan to address elevated levels of chronic toxicity in effluent and/or receiving water. The following protocol, which shall be incorporated into the TRE Workplan by the Discharger, shall be used for accelerated monitoring and TRE implementation:

 - a.** If the results of four consecutive accelerated monitoring tests do not exceed the chronic toxicity effluent limitation, the Discharger may cease accelerated monitoring and resume regular chronic toxicity monitoring. However, if there is adequate evidence of a pattern of effluent toxicity, the Regional Water Board's Executive Officer may require that the Discharger initiate a TRE.
 - b.** If the source(s) of the toxicity is easily identified (i.e., improper BMP implementation), the Discharger shall make necessary corrections to the Facility and shall continue accelerated monitoring until four consecutive accelerated tests do not exceed the effluent limitation. Upon confirmation that the chronic toxicity has been removed, the Discharger may cease accelerated monitoring and resume regular chronic toxicity monitoring.
 - c.** If the result of any accelerated toxicity test exceeds the effluent limitation, the Discharger shall cease accelerated monitoring and initiate a TRE to investigate the cause(s) and identify corrective actions to reduce or eliminate the chronic toxicity.

10. Chronic Toxicity Reporting

- a. Routine Reporting.** All toxicity test reports shall include the contracting laboratory's complete report provided to the Discharger and shall be in accordance with the appropriate "Report Preparation and Test Review" sections of the method manuals.

The WET test report shall contain a narrative report that includes details about WET test procedures and results, including the following:

i. Test Procedures.

- (a) Receipt and handling of the effluent sample that includes a tabular summary of initial water quality characteristics;
- (b) The source and make-up of the lab control/diluents water used for the test;
- (c) Any manipulations done to lab control/diluents and effluent such as filtration, nutrient addition, etc.;
- (d) Identification of any reference toxicant testing performed;
- (e) Tabular summary of test results for control water and each effluent dilution and statistics summary to include calculation of NOEC, TU_c , and IC_{25} ;
- (f) Identification of any anomalies or nuances in the test procedures or results; and
- (g) Summary and Conclusions section.

ii. Test Results. Test results shall include at a minimum, for each test:

- (a) Sample date(s);
- (b) Test initiation date;
- (c) Test species;
- (d) End point values for each dilution (e.g., number of young, growth rate, percent survival);
- (e) NOEC value(s) in percent effluent;

- (f) IC₁₅, IC₂₅, IC₄₀, and IC₅₀ values (or EC₁₅, EC₂₅...etc.) in percent effluent;
 - (g) TU_c values (100/NOEC);
 - (h) Mean percent mortality (\pm s.d.) after 96 hours in 100 percent effluent (if applicable);
 - (i) NOEC and LOEC values for reference toxicant test(s);
 - (j) IC50 or EC50 values(s) for reference toxicant test(s);
 - (k) Available water quality measurements for each test (e.g., pH, DO, temperature, conductivity, hardness, salinity, ammonia);
 - (l) Statistical methods used to calculate endpoints;
 - (m) The statistical output page, which includes the calculation of percent minimum significant difference (PMSD); and
 - (n) Results of applicable reference toxicant data with the statistical output page giving the species, NOEC, LOEC, type of toxicant, dilution water used, concentrations used, PMSD and dates tested; the reference toxicant control charts for each endpoint, which include summaries of reference toxicant tests performed by the contracting laboratory; and any information on deviations from standard test procedures or problems encountered in completing the test and how the problems were resolved.
- b. Quality Assurance Reporting.** Because the permit requires sublethal hypothesis testing endpoints from methods 1006.0 and 1007.0 in the test methods manual titled Short-term Methods for Estimating the Chronic Toxicity of Effluents and Receiving Waters to Marine and Estuarine Organisms (EPA-821-R-02-014, 2002), with-in test variability must be reviewed for acceptability and variability criteria (upper and lower PMSD bounds) must be applied, as directed under section 10.2.8 – Test Variability of the test methods manual. Under section 10.2.8, the calculated PMSD for both reference toxicant test and effluent toxicity test results must be compared with the upper and lower PMSD bounds variability criteria specified in Table 6 – Variability Criteria (Upper and Lower PMSD Bounds) for Sublethal Hypothesis Testing Endpoints Submitted Under NPDES Permits, following the review criteria in paragraphs 10.2.8.2.4.1 through 10.2.8.2.4.5 of the test methods manual. Based on this review, only accepted effluent toxicity test results shall be reported.

- c. Compliance Summary.** The results of the chronic toxicity testing shall be provided in the most recent self-monitoring report and shall include a summary table organized by test species, type of test (survival, growth or reproduction) and monitoring frequency (routine, accelerated or TRE) of toxicity data from at least three of the most recent samples. The final report shall clearly demonstrate that the Discharger is in compliance with water quality objectives and other permit requirements.

V. LAND DISCHARGE MONITORING REQUIREMENTS

This section is not applicable.

VI. RECLAMATION MONITORING REQUIREMENTS

This section is not applicable.

VII. RECEIVING WATER MONITORING REQUIREMENTS

No receiving water monitoring is required as part of this permit.

VIII. OTHER MONITORING REQUIREMENTS

A. Cooling Tower Maintenance Chemicals

The Discharger shall maintain a record of all chemicals used in cooling tower maintenance. This record shall indicate the date on which each maintenance chemical was used and whether that chemical contains any priority pollutants listed in 40 CFR 423, Appendix A. As discussed in section IV of the MRP, the addition of any chemicals used in cooling tower maintenance which contain priority pollutants shall trigger monitoring for the added priority pollutants. The Discharger shall submit a summary list of added chemicals in their monthly SMRs and indicate which chemicals contain priority pollutants.

IX. REPORTING REQUIREMENTS

A. General Monitoring and Reporting Requirements

1. The Discharger shall comply with all Standard Provisions (Attachment D) related to monitoring, reporting, and recordkeeping.
2. Schedules of Compliance. If applicable, the Discharger shall submit all reports and documentation required by compliance schedules that are established by this Order. Such reports and documentation shall be submitted to the Regional Water Board on or before each compliance date established by this Order. If noncompliance is reported, the Discharger shall

describe the reasons for noncompliance and a specific date when compliance will be achieved. The Discharger shall notify the Regional Water Board when it returns to compliance with applicable compliance dates established by schedules of compliance.

B. Self Monitoring Reports (SMRs)

1. The Discharger shall submit electronic Self-Monitoring Reports (SMRs) using the State Water Board’s California Integrated Water Quality System (CIWQS) Program Web site (<http://www.waterboards.ca.gov/ciwqs/index.html>). The CIWQS Web site provides additional directions for SMR submittal in the event there will be service interruption for electronic submittal.
2. The Discharger shall report in the SMR the results for all monitoring specified in this MRP under sections III through IX. The Discharger shall submit monthly SMRs including the results of all required monitoring using USEPA-approved test methods or other test methods specified in this Order. If the Discharger monitors any pollutant more frequently than required by this Order, the results of this monitoring shall be included in the calculations and reporting of the data submitted in the SMR.
3. Monitoring periods and reporting for all required monitoring shall be completed according to the following schedule:

Table E-6. Monitoring Periods and Reporting Schedule

| Sampling Frequency | Monitoring Period Begins On... | Monitoring Period | SMR Due Date |
|--------------------|--|---|--|
| Continuous | Permit effective date | All | First day of second calendar month following month of sampling |
| Daily | Permit effective date | (Midnight through 11:59 PM) or any 24-hour period that reasonably represents a calendar day for purposes of sampling. | First day of second calendar month following month of sampling |
| Weekly | Sunday following permit effective date or on permit effective date if on a Sunday | Sunday through Saturday | First day of second calendar month following month of sampling |
| Monthly | First day of calendar month following permit effective date or on permit effective date if that date is first day of the month | First day of calendar month through last day of calendar month | First day of second calendar month following month of sampling |

| Sampling Frequency | Monitoring Period Begins On... | Monitoring Period | SMR Due Date |
|--------------------|---|---|---|
| Quarterly | Closest of January 1, April 1, July 1, or October 1 following (or on) permit effective date | January through March April through June July through September October through December | First day of second calendar month following end of quarter |
| Annually | January 1 following (or on) permit effective date | January 1 through December 31 | March 1, each year |

4. Reporting Protocols. The Discharger shall report with each sample result the applicable reported Reporting Level (RL) and the current Method Detection Limit (MDL), as determined by the procedure in 40 CFR Part 136.

The Discharger shall report the results of analytical determinations for the presence of chemical constituents in a sample using the following reporting protocols:

- a. Sample results greater than or equal to the reported ML shall be reported as measured by the laboratory (i.e., the measured chemical concentration in the sample).
- b. Sample results less than the RL, but greater than or equal to the laboratory's MDL, shall be reported as "Detected, but Not Quantified," or DNQ. The estimated chemical concentration of the sample shall also be reported.

For the purposes of data collection, the laboratory shall write the estimated chemical concentration next to DNQ as well as the words "Estimated Concentration" (may be shortened to "Est. Conc."). The laboratory may, if such information is available, include numerical estimates of the data quality for the reported result. Numerical estimates of data quality may be percent accuracy (+ a percentage of the reported value), numerical ranges (low to high), or any other means considered appropriate by the laboratory.

- c. Sample results less than the laboratory's MDL shall be reported as "Not Detected," or ND.
- d. Dischargers are to instruct laboratories to establish calibration standards so that the ML value (or its equivalent if there is differential treatment of samples relative to calibration standards) is the lowest calibration standard. At no time is the Discharger to use analytical data derived from extrapolation beyond the lowest point of the calibration curve.

5. The Discharger shall submit SMRs in accordance with the following requirements:
 - a. The Discharger shall arrange all reported data in a tabular format. The data shall be summarized to clearly illustrate whether the Facility is operating in compliance with interim and/or final effluent limitations. The reported data shall include calculation of all effluent limitations that require averaging, taking of a median, or other computation. The Discharger is not required to duplicate the submittal of data that is entered in a tabular format within CIWQS. When CIWQS does not provide for entry into a tabular format within the system, the Discharger shall electronically submit the data in a tabular format as an attachment.
 - b. The Discharger shall attach a cover letter to the SMR. The information contained in the cover letter shall clearly identify:
 - i. Facility name and address;
 - ii. WDID number;
 - iii. Applicable period of monitoring and reporting;
 - iv. Violations of the WDRs (identified violations must include a description of the requirement that was violated and a description of the violation);
 - v. Corrective actions taken or planned; and
 - vi. The proposed time schedule for corrective actions.
 - c. SMRs must be submitted to the Regional Water Board, signed and certified as required by the Standard Provisions (Attachment D), to the address listed below:

Regional Water Quality Control Board
North Coast Region
5550 Skylane Blvd., Suite A
Santa Rosa, CA 95403

C. Other Reports

1. **Special Studies and Technical Report Submittals.** The Discharger shall report the results of any special studies, acute and chronic toxicity testing, TRE/TIE, PMP, and Pollution Prevention Plan required by Special Provisions – VI.C.2 and 3 of this Order. The Discharger shall submit reports with the first monthly SMR scheduled to be submitted on or immediately following the

report due date in compliance with SMR reporting requirements described in subsection X.B.5 above.

2. Annual Report. The Discharger shall submit an Annual Report to the Regional Water Board for each calendar year. The report shall be submitted by March 1st of the following year. The report shall, at a minimum, include the following:

a. Monitoring Data Summaries. Both tabular and, where appropriate, graphical summaries of the monitoring data and disposal records from the previous year. If the Discharger monitors any pollutant more frequently than required by this Order, using test procedures approved under title 40, section 136 or as specified in this Order, the results of this monitoring shall be included in the calculation and report of the data submitted SMR.

b. Compliance Reporting. A comprehensive discussion of the Facility's compliance (or lack thereof) with all effluent limitations and other WDRs, and the corrective actions taken or planned, which may be needed to bring the discharge into full compliance with the Order.

c. Solids Handling and Disposal Activity Reporting. The Dischargers shall both submit, as part of the annual report to the Regional Water Board, a description of the Dischargers' solids handling, disposal, and reuse activities over the previous calendar year. At a minimum, the report shall contain:

i. Annual fly ash production, in dry tons.

ii. Annual bottom ash production, in dry tons.

iii. A schematic diagram showing all ash handling facilities, if any, and an ash flow diagram.

iv. Methods of final disposal of fly and bottom ash.

D. Spills and Overflows Notification

1. All spills equal to or in excess of 1,000 gallons or any size spill that results in a discharge to a drainage channel or a surface water:

a. As soon as possible, but not later than 2 hours after becoming aware of the discharge, the Discharger shall notify the State Office of Emergency Services (OES), the local health officer or directors of environmental

health with jurisdiction over affected water bodies or land areas, and the Regional Water Board¹².

Information to be provided verbally to the Regional Water Board includes:

- i. Name and contact information of caller;
 - ii. Date, time and location of spill occurrence;
 - iii. Estimates of spill volume, rate of flow, and spill duration;
 - iv. Surface water bodies impacted, if any;
 - v. Cause of spill;
 - vi. Cleanup actions taken or repairs made; and
 - vii. Responding agencies.
- b.** As soon as possible, but not later than 24 hours after becoming aware of a discharge, the Discharger shall submit to the Regional Water Board a certification that the State Office of Emergency Services and the local health officer or directors of environmental health with jurisdiction over affected water bodies or land areas have been notified of the discharge. For the purpose of this requirement, "certification" means an OES certification number and, for the local health department, name of local health staff, department name, phone number and date and time contacted.
- c. Within five (5) business days**, the Discharger shall submit a written report to the Regional Water Board office. The report must include all available details related to the cause of the spill and corrective action taken or planned to be taken, as well as copies of reports submitted to other agencies.

Information to be provided in writing includes:

- i. Information provided in verbal notification;
 - ii. Other agencies notified by phone;
 - iii. Detailed description of cleanup actions and repairs taken; and
 - iv. Description of actions that will be taken to minimize or prevent future spills.
- d.** In the cover letter of the monthly monitoring report, the Discharger shall include a brief written summary of the event and any additional details

¹² The contact number for spill reporting for the Office of Emergency Services is (800) 852-7550. The contact number of the Regional Water Board during normal business hours is (707) 576-2220. After normal business hours, spill reporting to OES will satisfy the 2 hour notification requirement for the Regional Water Board.

related to the cause or resolution of the event, including, but not limited to results of any water quality monitoring conducted.

2. Discharges less than 1,000 gallons that do not reach a drainage channel or a surface water:
 - a. As soon as possible, but not later than 24 hours after becoming aware of the discharge, the Discharger shall notify the Regional Water Board and provide the applicable information specified in requirement X.E1.A of this MRP.
 - b. In the cover letter of the monthly monitoring report, the Discharger shall include a written description of the event.

E. Discharge Monitoring Reports (DMRs)

This section is not applicable.

ATTACHMENT F – FACT SHEET

Table of Contents

| | | |
|-------|--|------|
| I. | Permit Information..... | F-3 |
| II. | Facility Description | F-4 |
| | A. Description of Wastewater Treatment or Controls | F-5 |
| | B. Discharge Points and Receiving Waters | F-5 |
| | C. Summary of Existing Requirements and Self-Monitoring Report (SMR) Data..... | F-5 |
| | D. Planned Changes | F-6 |
| III. | Applicable Plans, Policies, and Regulations..... | F-7 |
| | A. Legal Authorities..... | F-7 |
| | B. California Environmental Quality Act (CEQA)..... | F-8 |
| | C. State and Federal Regulations, Policies, and Plans..... | F-8 |
| IV. | Rationale For Effluent Limitations and Discharge Specifications | F-12 |
| | A. Discharge Prohibitions..... | F-13 |
| | B. Technology-Based Effluent Limitations | F-15 |
| | C. Water Quality-Based Effluent Limitations (WQBELs) | F-21 |
| | D. Final Effluent Limitations | F-40 |
| | E. Interim Effluent Limitations | F-44 |
| | F. Land Discharge Specifications | F-44 |
| | G. Reclamation Specifications | F-44 |
| V. | Rationale for Receiving Water Limitations..... | F-45 |
| | A. Surface Water..... | F-45 |
| VI. | Rationale for Monitoring and Reporting Requirements | F-45 |
| | A. Influent Monitoring | F-45 |
| | B. Effluent Monitoring..... | F-46 |
| | C. Whole Effluent Toxicity Testing Requirements | F-47 |
| | D. Land Discharge Monitoring Requirements | F-47 |
| | E. Receiving Water Monitoring | F-47 |
| | F. Other Monitoring Requirements..... | F-48 |
| VII. | Rationale for Provisions | F-48 |
| | A. Standard Provisions | F-48 |
| | B. Regional Water Board Standard Provisions | F-48 |
| | C. Special Provisions | F-49 |
| VIII. | Public Participation..... | F-52 |
| | A. Notification of Interested Parties..... | F-52 |
| | B. Written Comments..... | F-52 |
| | C. Public Hearing | F-52 |

| | |
|---|------|
| D. Waste Discharge Requirements Petitions | F-53 |
| E. Information and Copying | F-53 |
| F. Register of Interested Persons | F-53 |
| G. Additional Information..... | F-54 |

List of Tables

| | |
|--|------|
| Table F-1. Facility Information..... | F-3 |
| Table F-2. Historic Effluent Limitations and Monitoring Data for Boiler and Cooling Tower Blowdown | F-6 |
| Table F-3. Historical Effluent Limitations and Monitoring Data for Low Volume Wastes..... | F-6 |
| Table F-4. Historical Effluent Limitations and Monitoring Data for Gross Effluent..... | F-6 |
| Table F-5. Basin Plan Beneficial Uses | F-8 |
| Table F-6. Ocean Plan Beneficial Uses | F-10 |
| Table F-7. Low Volume Wastes BPT ELGs | F-18 |
| Table F-8. Cooling Tower Blowdown BPT ELGs | F-18 |
| Table F-9. Cooling Water Blowdown BAT ELGs..... | F-19 |
| Table F-10. TBELs at Monitoring Locations M-010..... | F-21 |
| Table F-11. TBELs at Monitoring Location M-020..... | F-21 |
| Table F-12. TBELs at Monitoring Locations M-001..... | F-21 |
| Table F-13. Ocean RPA Summary Results..... | F-26 |
| Table F-14. Background Seawater Concentration – Ocean Plan..... | F-36 |
| Table F-15. Table B Water Quality Objectives | F-36 |
| Table F-16. Table B Mass-based Effluent Limitations..... | F-38 |
| Table F-17. Final WQBELs for Ocean Plan Table B Pollutants for Gross Effluent Waste (Monitoring Location M-001)..... | F-39 |
| Table F-18. Summary of Final Effluent Limitations at Discharge Point 001 (Monitoring Location M-001) | F-43 |
| Table F-19. Summary of Final Effluent Limitations at Discharge Point 010 (Monitoring Locations M-010) | F-43 |
| Table F-20. Summary of Final Effluent Limitations at Discharge Point 020 | F-44 |

ATTACHMENT F – FACT SHEET

As described in section II of this Order, this Fact Sheet includes the legal requirements and technical rationale that serve as the basis for the requirements of this Order.

This Order has been prepared under a standardized format to accommodate a broad range of discharge requirements for dischargers in California. Only those sections or subsections of this Order that are specifically identified as “not applicable” have been determined not to apply to this Discharger. Sections or subsections of this Order not specifically identified as “not applicable” are fully applicable to this Discharger.

I. PERMIT INFORMATION

The following table summarizes administrative information related to the Facility.

Table F-1. Facility Information

| | |
|---|---|
| WDID | 1B85026RHUM |
| Discharger | DG Fairhaven Power, LLC |
| Name of Facility | Fairhaven Power Facility |
| Facility Address | 97 Bay Street |
| | Samoa, CA 95564 |
| | Humboldt County |
| Facility Contact, Title and Phone | Bob Marino, General Manager, (707) 445-5434 |
| Authorized Person to Sign and Submit Reports | Bob Marino, General Manager |
| Mailing Address | 97 Bay Street |
| | Samoa, CA 95564 |
| | Humboldt County |
| Billing Address | Same as Mailing Address |
| Type of Facility | Electricity Generation (SIC code 4911) |
| Major or Minor Facility | Minor |
| Threat to Water Quality | 2 |
| Complexity | C |
| Pretreatment Program | Not Applicable |
| Reclamation Requirements | Not Applicable |
| Facility Maximum Anticipated Discharge Flow | 0.350 million gallons per day (MGD) |
| Facility Median Flow | 0.146 MGD |
| Watershed | Eureka Plain |

| | |
|-----------------------------|---------------|
| Receiving Water | Pacific Ocean |
| Receiving Water Type | Ocean |

- A.** DG Fairhaven Power, LLC (hereinafter Discharger) is the owner and operator of the Fairhaven Power Facility (hereinafter Facility).

For the purposes of this Order, references to the “discharger” or “permittee” in applicable federal and state laws, regulations, plans, or policy are held to be equivalent to references to the Discharger herein.

- B.** The Facility discharges process water to the Pacific Ocean a waters of the United States. The Facility is currently regulated by Order No. R1-2002-0076 which was adopted on August 22, 2002. The terms and conditions of the current Order have been automatically continued and remain in effect until new Waste Discharge Requirements (WDRs) and National Pollutant Discharge Elimination System (NPDES) permit are adopted pursuant to this Order.
- C.** The Discharger filed a Report of Waste Discharge and submitted an application for renewal of its WDRs and NPDES permit on March 17, 2010.

II. FACILITY DESCRIPTION

The Discharger owns and operates a power generation facility in Samoa, California. The Facility is located on the Samoa Peninsula of Humboldt Bay, with Humboldt Bay to the east and the Pacific Ocean to the west. The Facility was formerly owned by Eel River Sawmills and in April 2005 was acquired by DG Fairhaven Power, LLC.

The Facility combusts wood waste to produce electricity using a steam-turbine power generation process. Power generation uses approximately 145,000 gallons of process water per day from the Humboldt Bay Municipal Water District as a source water.

The source water from Humboldt Bay Municipal Water District is used in non-contact processes to cool screws and bearings and to condense steam (via cooling tower). Additionally, source water is treated via reverse osmosis, a demineralizer, and a deaerator prior to being pumped to the boiler to generate steam. A schematic of process waters is provided in Attachment C to this Order.

Process waters discharged under this Order include cooling tower blowdown, low volume wastes (including: boiler water blowdown, screw and bearing cooling water, reverse osmosis concentrate, and demineralizer back-wash),

and intermittent wastes (including: cooling tower cleaning wastes). The metal cleaning wastes from boiler cleaning also represent an intermittent waste stream, which is applied to incoming fuel and is not discharged to the Pacific Ocean.

A. Description of Wastewater Treatment or Controls

Process water is treated at various points in the power generation cycle before being discharged as effluent. The reverse osmosis (RO) unit and a demineralizer are used to reduce the concentration of total dissolved solids in the boiler water. The demineralizer back-wash, boiler blowdown and RO concentrate are then routed back to the cooling tower. More than 60% of the cooling tower water is evaporated. The remaining cooling tower water is blown down via a valve to an oil/water separator and then discharged.

The Discharger currently stores filtered bottom ash and associated wash water (FBAWW) in an on-site containment unit that does not produce a discharge. The Discharger plans to develop a closed-loop treatment system to handle the FBAWW waste which will not commingle with existing process waters or discharge to a water of the United States.

Sanitary wastewater flows originating from employee facilities (i.e., washrooms, restrooms) are discharged to an on-site septic tank and leach field treatment system. Sanitary flows are not discharged to a water of the United States. The on-site system has been designed and constructed in accordance with Humboldt County regulations and Regional Water Quality Control Board, North Coast Region (Regional Water Board) policies.

B. Discharge Points and Receiving Waters

The process water is discharged to the Pacific Ocean via the Freshwater Tissue outfall (Discharge Point 001). The outfall is a 48-inch diameter pipeline that terminates approximately 1.5 miles off-shore.

C. Summary of Existing Requirements and Self-Monitoring Report (SMR) Data

1. Effluent limitations contained in Order No. R1-2002-0076 for discharges from Discharge Point 001 (Monitoring Location M-001) and internal outfalls with representative monitoring data from the term of Order No. R1-2002-0076 are as follows:

Table F-2. Historic Effluent Limitations and Monitoring Data for Boiler and Cooling Tower Blowdown

| Parameter | Units | Effluent Limitations | | Monitoring Data (from Nov 2002 to Sept 2010) | |
|-------------------------|-------|----------------------|----------------|---|------------------------|
| | | Daily Max | 30-Day Average | Highest Daily Max | Highest 30-Day Average |
| Free Available Chlorine | mg/L | 0.5 | 0.2 | 0.2 | 0.2 |
| Total Chromium | mg/L | 0.2 | 0.2 | <0.05 | <0.05 |
| Zinc | mg/L | 1.0 | 1.0 | 0.18 | 0.18 |
| pH | s.u. | 6.0 – 9.0 | | 9 | |

Table F-3. Historical Effluent Limitations and Monitoring Data for Low Volume Wastes

| Parameter | Units | Effluent Limitations | | Monitoring Data (from March 2003 to Sept 2010) | |
|------------------------|-------|----------------------|----------------|---|------------------------|
| | | Daily Max | 30-Day Average | Highest Daily Max | Highest 30-Day Average |
| Total Suspended Solids | mg/L | 100 | 30 | 16 | 16 |
| Grease and Oil | mg/L | 20 | 15 | 7.6 | 7.6 |
| pH | s.u. | 6.0 – 9.0 | | 7.3 – 8.7 | |

Table F-4. Historical Effluent Limitations and Monitoring Data for Gross Effluent

| Parameter | Units | Effluent Limitations | | | Monitoring Data (from Nov 2002 to Sept 2010) | | |
|------------------|-------|----------------------|-----------|-------------------|--|-------------------|---------------------------|
| | | 6-Month Median | Daily Max | Instantaneous Max | Highest 6-Month Median | Highest Daily Max | Highest Instantaneous Max |
| Copper | mg/L | 0.12 | 1.2 | 3.2 | 0.82 | 0.99 | 0.99 |
| Lead | mg/L | 0.23 | 0.93 | 2.3 | 0.05 | 0.05 | 0.05 |
| Zinc | mg/L | 1.4 | 8.4 | 22.3 | 0.51 | 0.72 | 0.72 |
| Acute Toxicity | TUa | --- | --- | --- | --- | --- | --- |
| Chronic Toxicity | TUc | 115 | --- | --- | 1 | --- | --- |

D. Planned Changes

In May 2009, Freshwater Tissue shut down and disconnected its water supply, which eliminated the pulp mill contribution of 2.85 MGD of effluent discharged through the shared outfall. Since then, the Facility's discharge of 145,000 gallons per day has been the only effluent discharging through the outfall. This reduced discharge volume increases the probability of a

silt blockage of the outfall which could render effluent disposal through Discharge Point 001 infeasible.

In 2009, the Regional Water Board issued ACL Order No. R1-2009-0042 which formalized an agreement between the Regional Water Board and the Discharger regarding the creation and enhancement of an area of freshwater wetlands located in close proximity to the Facility. Due to comments received from the Coastal Commission during the California Environmental Quality Act (CEQA) process and water quality concerns from the Regional Water Board, the Discharger is performing a feasibility study to analyze the viability of this project relative to various alternatives. Upon completion of the feasibility study, and receipt of a new report of waste discharge (ROWD), this permit may be reopened to permit a new discharge location.

Further, the Discharger is investigating the use of a closed loop system to wash bottom ash and recycle the wash water onto incoming fuel just prior to incineration. The Discharger currently has approximately 7,500 tons of Bottom Ash stored onsite, but has been trucking it offsite to Anderson Landfill as of July, 2011. Since November 2011, the Discharge has been trucking Bottom Ash to Anderson Landfill at a rate of two truckloads of 25 tons each per week. The Discharger has requested authorization to use washed Bottom Ash as roadbase. Fly Ash is currently disposed of to land in accordance with a diversion program administered by SHN Consulting Engineers & Geologists, Inc. This Permit requires that any Fly Ash disposal program be concurred by the Executive Officer. Regional Water Board staff is currently reviewing all available Bottom Ash analytical data to determine a region-wide permitting mechanism for disposal of Bottom and Fly Ash. Bottom and Fly Ash disposal must comply with Section VI.C.6.a.i of this Permit.

III. APPLICABLE PLANS, POLICIES, AND REGULATIONS

The requirements contained in the proposed Order are based on the requirements and authorities described in this section. This section provides supplemental information, where appropriate, for the plans, policies, and regulations relevant to the discharge.

A. Legal Authorities

This Order is issued pursuant to section 402 of the federal Clean Water Act (CWA) and implementing regulations adopted by the U.S. Environmental Protection Agency (USEPA) and chapter 5.5, division 7 of the California Water Code (commencing with section 13370). It shall serve as a NPDES

permit for point source discharges from this Facility to surface waters. This Order also serves as WDRs pursuant to article 4, chapter 4, division 7 of the Water Code (commencing with section 13260).

B. California Environmental Quality Act (CEQA)

Under Water Code section 13389, this action to adopt an NPDES permit is exempt from the provisions of CEQA, Public Resources Code sections 21100 through 21177.

C. State and Federal Regulations, Policies, and Plans

1. Water Quality Control Plans. The Regional Water Board adopted a *Water Quality Control Plan for the North Coast Region* (hereinafter Basin Plan) that designates beneficial uses, establishes water quality objectives, and contains implementation programs and policies to achieve those objectives for all waters addressed through the plan. In addition, the Basin Plan implements State Water Resources Control Board (State Water Board) Resolution No. 88-63, which establishes State policy that all waters, with certain exceptions, should be considered suitable or potentially suitable for municipal or domestic supply. Beneficial uses applicable to the Pacific Ocean and freshwater wetlands are summarized in Table F-5, below:

Table F-5. Basin Plan Beneficial Uses

| Discharge Point | Receiving Water Name | Beneficial Use(s) |
|-----------------|----------------------|-------------------|
|-----------------|----------------------|-------------------|

| Discharge Point | Receiving Water Name | Beneficial Use(s) |
|-----------------|----------------------|---|
| 001 | Pacific Ocean | <p><u>Existing:</u></p> <ul style="list-style-type: none"> • Navigation (NAV) • Water Contact Recreation (REC1) • Non-Contact Water Recreation (REC2) • Commercial and Sport Fishing (COMM) • Marine Habitat (MAR) • Wildlife Habitat (WILD) • Preservation of Rare, Threatened, or Endangered Species (RARE) • Migration of Aquatic Organisms (MIGR) • Spawning, Reproduction, and/or Early Development (SPWN) • Shellfish Harvesting (SHELL) • Aquaculture (AQUA) <p><u>Potential:</u></p> <ul style="list-style-type: none"> • Industrial Service Supply (IND) • Industrial Process Supply (PRO) • Preservation of Areas of Special Biological Significance (ASBS) |

Requirements of this Order implement the Basin Plan.

2. Thermal Plan. The State Water Board adopted a *Water Quality Control Plan for Control of Temperature in the Coastal and Interstate Water and Enclosed Bays and Estuaries of California* (Thermal Plan) on May 18, 1972, and amended this plan on September 18, 1975. This plan contains temperature objectives for coastal waters. Requirements of this Order implement the Thermal Plan.

3. California Ocean Plan. The State Water Board adopted the Ocean Plan in 1972 and amended it in 1978, 1983, 1988, 1990, 1997, 2000, 2005, and 2009. The State Water Board adopted the latest amendment on September 15, 2009 and it became effective on March 10, 2010. The Ocean Plan is applicable, in its entirety, to point source discharges to the ocean. The Ocean Plan identifies beneficial uses of ocean waters of the State to be protected as summarized below.

Table F-6. Ocean Plan Beneficial Uses

| Discharge Point | Receiving Water Name | Beneficial Use(s) |
|-----------------|----------------------|--|
| 001 | Pacific Ocean | <u>Existing:</u> <ul style="list-style-type: none"> • Industrial Water Supply • Water Contact and Non-Contact Recreation (including aesthetic enjoyment) • Navigation • Commercial and Sport Fishing • Mariculture • Preservation and enhancement of designated Areas of Special Biological Significance (ASBS) • Rare and Endangered Species • Marine Habitat • Fish Migration • Fish Spawning; and • Shellfish Harvesting |

4. National Toxics Rule (NTR) and California Toxics Rule (CTR).

USEPA adopted the NTR on December 22, 1992, and later amended it on May 4, 1995 and November 9, 1999. About forty criteria in the NTR applied in California. On May 18, 2000, USEPA adopted the CTR. The CTR promulgated new toxics criteria for California and, in addition, incorporated the previously adopted NTR criteria that were applicable in the State. The CTR was amended on February 13, 2001. These rules contain water quality criteria for priority pollutants.

5. Technology Based Effluent Limitations.

Section 301(b) of the CWA and implementing USEPA permit regulations at section 122.44, title 40 of the Code of Federal Regulations, require that permits include conditions meeting applicable technology-based requirements at a minimum, and any more stringent effluent limitations necessary to meet applicable water quality standards. As described in section IV.B.2 of the Fact Sheet, based on BPJ, the discharge authorized by this Order must meet minimum federal technology-based requirements based on Effluent Limitations Guidelines, Pretreatment Standards, and New Source Performance Standards for the Steam Electric Power Generating Point Source Category in 40 CFR Part 423 (ELGs). The Regional Water Board has considered the factors listed in the California Water Code (CWC) sections 13241 and 13263 in establishing these requirements. A detailed discussion of the technology-based effluent limitations development is included in the Fact Sheet (Attachment F).

6. Water Quality-Based Effluent Limitations.

Section 301(b) of the CWA and section 122.44(d) require that permits include limitations

more stringent than applicable federal technology-based requirements where necessary to achieve applicable water quality standards.

Section 122.44(d)(1)(i) mandates that permits include effluent limitations for all pollutants that are or may be discharged at levels that have the reasonable potential to cause or contribute to an exceedance of a water quality standard, including numeric and narrative objectives within a standard. Where reasonable potential has been established for a pollutant, but there is no numeric criterion or objective for the pollutant, water quality-based effluent limitations (WQBELs) must be established using: (1) USEPA criteria guidance under CWA section 304(a), supplemented where necessary by other relevant information; (2) an indicator parameter for the pollutant of concern; or (3) a calculated numeric water quality criterion, such as a proposed state criterion or policy interpreting the state's narrative criterion, supplemented with other relevant information, as provided in section 122.44(d)(1)(vi).

- 7. Compliance Schedules and Interim Requirements.** The State Water Board adopted Resolution No. 2008-0025 on April 15, 2008, titled Policy for Compliance Schedules in National Pollutant Discharge Elimination System Permits, which includes compliance schedule policies for pollutants that are not addressed by the SIP. This Policy became effective on August 27, 2008. This Order does not include compliance schedules or interim effluent limitations.
- 8. Alaska Rule.** On March 30, 2000, USEPA revised its regulation that specifies when new and revised state and tribal water quality standards (WQS) become effective for CWA purposes (section 131.21, 65 Fed. Reg. 24641 (April 27, 2000)). Under the revised regulation (also known as the Alaska rule), new and revised standards submitted to USEPA after May 30, 2000, must be approved by USEPA before being used for CWA purposes. The final rule also provides that standards already in effect and submitted to USEPA by May 30, 2000, may be used for CWA purposes, whether or not approved by USEPA.
- 9. Antidegradation Policy.** Section 131.12, title 40 of the Code of Federal Regulations (section 131.12) requires that the state water quality standards include an antidegradation policy consistent with the federal policy. The State Water Board established California's antidegradation policy in State Water Board Resolution No. 68-16. Resolution No. 68-16 incorporates the federal antidegradation policy where the federal policy applies under federal law. Resolution No. 68-16 requires that existing water quality be maintained unless degradation

is justified based on specific findings. The Regional Water Board's Basin Plan implements, and incorporates by reference, both the State and federal antidegradation policies. The permitted discharge must be consistent with the antidegradation provision of section 131.12 and State Water Board Resolution No. 68-16. Section IV.D.2 of this Fact Sheet discusses how the requirements of this Order satisfy the Antidegradation Policy.

10. Anti-Backsliding Requirements. Sections 402(o)(2) and 303(d)(4) of the CWA and federal regulations at title 40, Code of Federal Regulations¹ section 122.44(l) prohibit backsliding in NPDES permits. These anti-backsliding provisions require that effluent limitations in a reissued permit must be as stringent as those in the previous permit, with some exceptions in which limitations may be relaxed. Section IV.D.1 of this Fact Sheet provides a detailed discussion of how the requirements of this Order satisfy anti-backsliding requirements.

IV. RATIONALE FOR EFFLUENT LIMITATIONS AND DISCHARGE SPECIFICATIONS

The CWA requires point source dischargers to control the amount of conventional, non-conventional, and toxic pollutants that are discharged into the waters of the United States. The control of pollutants discharged is established through effluent limitations and other requirements in NPDES permits. There are two principal bases for effluent limitations: Section 122.44(a) requires that permits include applicable technology-based limitations and standards; and Section 122.44(d) requires that permits include water quality-based effluent limitations (WQBELs) to attain and maintain applicable numeric and narrative water quality criteria to protect the beneficial uses of the receiving water. Where the discharge has the reasonable potential to cause or contribute to an excursion above a narrative criterion, but numeric water quality objectives have not been established, WQBELs may be established using one or more of three methods described at section 122.44(d)(vi). First, WQBELs may be established using a calculated water quality criterion, such as a proposed State criterion or an explicit State policy or regulation interpreting its narrative criterion. Second, WQBELs may be established on a case-by-case basis using USEPA criteria guidance published under CWA section 304(a). Third, WQBELs may be established using an indicator parameter for the pollutant of concern.

¹ All further statutory references are to title 40 of the Code of Federal Regulations unless otherwise indicated.

A. Discharge Prohibitions

- 1. Discharge Prohibition III.A.** The discharge of any waste not disclosed by the Discharger or not within the reasonable contemplation of the Regional Water Board is prohibited.

This prohibition is based on the Basin Plan and State Water Board Order WQO No. 2002-0012 regarding the petition of WDRs Order No. 01-072 for the East Bay Municipal Utility District and Bay Area Clean Water Agencies. In State Water Board Order No. WQO 2002-0012, the State Water Board found that this prohibition is acceptable in orders, but should be interpreted to apply only to constituents that are either not disclosed by the Discharger, or are not reasonably anticipated to be present in the discharge but have not been disclosed by the Discharger. It specifically does not apply to constituents in the discharge that do not have “reasonable potential” to exceed water quality objectives.

The State Water Board has stated that the only pollutants not covered by this prohibition are those which were “*disclosed to the Ordering and ... can be reasonably contemplated.*” [In re the Petition of East Bay Municipal Utilities District et al., (State Water Board, 2002) Order No. WQO 2002-0012, p. 24] In that Order, the State Water Board cited a case which held the Discharger is liable for the discharge of pollutants “*not within the reasonable contemplation of the permitting authority ... whether spills or otherwise...*” [*Piney Run Preservation Assn. v. County Commissioners of Carroll County, Maryland* (4th Cir. 2001) 268 F. 3d 255, 268.] Thus the State Water Board authority provides that, to be permissible, the constituent discharged (1) must have been disclosed by the Discharger and (2) can be reasonably contemplated by the Regional Water Board.

Whether or not the Discharger reasonably contemplates the discharge of a constituent is not relevant. What matters is whether the Discharger disclosed the constituent to the Regional Water Board or whether the presence of the pollutant in the discharge can otherwise be reasonably contemplated by the Regional Water Board at the time of Order adoption

- 2. Discharge Prohibition III.B.** The discharge of waste to Humboldt Bay is prohibited.

This prohibition is retained from Order No. R1-2002-0076.

- 3. Discharge Prohibition III.C.** Creation of pollution, contamination, or nuisance, as defined by Section 13050 of the California Water Code is prohibited.

This prohibition is based on Section 13050 of the Water Code, and has been retained from Order No. R1-2002-0076.

- 4. Discharge Prohibition III.D.** The discharge of domestic waste, treated or untreated, to surface waters is prohibited.

This prohibition is based on the Basin Plan policy on the control of water quality with respect to on-site waste treatment and disposal practices, and has been retained from Order No. R1-2002-0076.

- 5. Discharge Prohibition III.E.** The discharge of waste at any point not described in Finding II.B. or authorized by any State Water Board or other Regional Water Board permit is prohibited.

This is a general prohibition that allows the Discharger to discharge waste only in accordance with waste discharge requirements. It is based on Sections 301 and 402 of the federal CWA and CWC Section 13263. This prohibition replaces Discharge Prohibition A.2 of Order No. R1-2002-0076 which prohibited discharges from the Facility to Humboldt Bay.

- 6. Discharge Prohibition III.F.** The discharge of waste to land that is not owned by, or under agreement to use by, the Discharger is prohibited.

This prohibition is retained from Order No. R1-2002-0076. Land used for the application of wastewater must be owned by the Discharger or be under control of the Discharger by contract so that the Discharger maintains a means for ultimate disposal of treated wastewater.

- 7. Discharger Prohibition III.G.** The intentional introduction of pollutant-free wastewater to the collection, treatment, and disposal system for purposes of dilution is prohibited. The discharge of noncontact cooling water is not subject to this prohibition.

This prohibition is retained from Order No. R1-2002-0076 and is necessary to ensure that the Discharger's treatment system is demonstrating adequate treatment performance necessary to prevent an exceedance of receiving water quality standards or objectives.

- 8. Discharge Prohibition III.H.** The discharge of waste to shallow usable groundwaters of the Samoa Peninsula is prohibited. Notwithstanding

this prohibition, the discharge of wastes from employee sanitary facilities in compliance with the North Coast Basin Plan Policy on the Control of Water Quality with Respect to On-Site Waste Treatment and Disposal Practices is authorized.

This prohibition is retained from Order No. R1-2002-0076 and is based on the Basin Plan and Section 13263 of the Water Code. The Facility has an on-site septic system for subsurface disposal of sanitary waste. The discharge of sanitary waste to either Discharge Points 001 or 002 is neither anticipated nor permitted.

- 9. Discharge Prohibition III.I.** Discharge of any radiological, chemical, or biological warfare agent, or high-level radioactive waste into the ocean is prohibited.

This prohibition is established by this Order and is based on the discharge prohibitions contained in the Ocean Plan.

- 10. Discharge Prohibition III.J.** Discharge of sludge directly into the ocean or into a waste stream that discharges to the ocean is prohibited.

This prohibition is established by this Order and is based on the discharge prohibitions contained in the Ocean Plan.

- 11. Discharge Prohibition III.K.** Discharge of metal cleaning wastes directly into the ocean or into a waste stream that discharges to the ocean is prohibited.

This prohibition is established by this Order to ensure compliance with 40 CFR 423.12 (b) (5), which contains technology-based effluent limitations for metal cleaning wastes. Since this waste stream exists, but it has not been monitored and is not anticipated for discharge into the ocean, this prohibition is a substitute for the otherwise requisite effluent limitations.

B. Technology-Based Effluent Limitations

1. Scope and Authority

CWA Section 301(b) and 40 CFR 122.44(a) require that permits include applicable technology-based limitations and standards. The CWA requires that technology-based effluent limitations are established based on several levels of controls:

- a. Best practicable treatment control technology (BPT) represents the average of the best performance by plants within an industrial category or subcategory. BPT standards apply to toxic, conventional, and non-conventional pollutants.
- b. Best available technology economically achievable (BAT) represents the best existing performance of treatment technologies that are economically achievable within an industrial point source category. BAT standards apply to toxic and non-conventional pollutants.
- c. Best conventional pollutant control technology (BCT) represents the control from existing industrial point sources of conventional pollutants including five-day biochemical oxygen demand (BOD), total suspended solids (TSS), fecal coliform, pH, and oil and grease. The BCT standard is established after considering the “cost reasonableness” of the relationship between the cost of attaining a reduction in effluent discharge and the benefits that would result, and also the cost effectiveness of additional industrial treatment beyond BPT.
- d. New source performance standards (NSPS) represent the best available demonstrated control technology standards. The intent of NSPS guidelines is to set limitations that represent state-of-the-art treatment technology for new sources.

The CWA requires USEPA to develop effluent limitations, guidelines and standards (ELGs) representing application of BPT, BAT, BCT, and NSPS. Section 402(a)(1) of the CWA and Section 125.3 of the Code of Federal Regulations authorize the use of best professional judgment (BPJ) to derive technology-based effluent limitations on a case-by-case basis where ELGs are not available for certain industrial categories and/or pollutants of concern. Where BPJ is used, the permit writer must consider specific factors outlined in Section 125.3.

2. Applicable Technology-Based Effluent Limitations

Pursuant to CWA Section 306(b)(1)(B), USEPA has established standards of performance (technology-based limitations and standards) for steam electric power plants at 40 CFR 423, Effluent Limitations Guidelines, Pretreatment Standards, and New Source Performance Standards for the Steam Electric Power Generating Point Source Category. The requirements of 40 CFR 423 are applicable to discharges resulting from the operation of a generating unit by an establishment primarily engaged in the generation of electricity for

distribution and sale which results primarily from a process utilizing fossil-type fuel or nuclear fuel. The Facility combusts wood waste to produce electricity using a steam-turbine power generation process, however operations and wastes generated are similar to those addressed in 40 CFR 423 for facilities utilizing fossil-type fuels. Because operations and wastes generated at the Facility are similar to those addressed in 40 CFR 423, the previous Order established effluent limitations and permit conditions for the Discharger similar to those contained in 40 CFR 423. Consistent with the previous Order, this Order applies the requirements of 40 CFR 423 to the Facility based on BPJ.

When establishing permit requirements based on BPJ, 40 CFR 125.3(c)(2) requires the consideration of appropriate factors listed in 40 CFR 125.3(d), including cost of application of technology, age of equipment, process employed, engineering aspects, process changes, and non-water quality environmental impacts. Because the requirements of 40 CFR 423 have historically been applied to the Facility, additional costs associated with the application of these requirements are not expected to be significant. Further, because the requirements of 40 CFR 423 have been applied in the previous Order, the available technology, process wastewaters, and engineering are sufficient to meet the requirements established in 40 CFR 423.

The Facility is considered an existing facility; therefore, the Order includes effluent limitations based on BPT and BAT. The ELGs do not include standards of performance based on BCT. Section IV.B.2.a details the specific technology-based effluent limitations (BPT and BAT) applicable to the Facility.

Table A of the Ocean Plan contains technology-based effluent limitations for discharges to the Ocean. Effluent limitations based on Table A of the Ocean Plan are not applicable to the Discharger's process wastewater because effluent guidelines have been established.

a. Effluent Limitation Guidelines Based on 40 CFR 423

i. Standards of Performance Based on BPT

- (a) The pH of all discharges, except once-through cooling water, shall be within the range of 6.0 – 9.0. [40 CFR 423.12(b)(1)].

- (b) There shall be no discharge of polychlorinated biphenyl compounds such as those commonly used for transformer fluid. [40 CFR 423.12(b)(2)].
- (c) The quantity of pollutants discharged from low volume waste sources shall not exceed the quantity determined by multiplying the flow of low volume waste sources times the concentration listed in Table F-7 below [40 CFR 423.12(b)(3)]. Low volume wastes are defined as those wastewater sources for which specific limitations are not established by the ELGs at 40 CFR 423 (i.e. all process streams other than cooling tower blowdown). This includes, but is not limited to, boiler blowdown, screw and bearing cooling water, reverse osmosis concentrate, and demineralizer backwash water.

Table F-7. Low Volume Wastes BPT ELGs

| Parameter | Units | 30-Day Average Concentration | Daily Maximum Concentration |
|------------------------------|-------|------------------------------|-----------------------------|
| Total Suspended Solids (TSS) | mg/L | 30 | 100 |
| Oil and Grease | mg/L | 15 | 20 |

- (d) The quantity of pollutants discharged in cooling tower blowdown shall not exceed the quantity determined by multiplying the cooling tower blowdown sources times the concentration listed in Table F-8. [40 CFR 423.12(b)(7)].

Table F-8. Cooling Tower Blowdown BPT ELGs

| Parameter | Units | Average Concentration ² | Maximum Concentration ³ |
|-------------------------|-------|------------------------------------|------------------------------------|
| Free Available Chlorine | mg/L | 0.2 | 0.5 |

- (e) Neither free available chlorine nor total residual chlorine may be discharged from any one unit for more than two hours in any one day and not more than one unit in any plant may

² The term “average concentration”, as it relates to chlorine discharge under ELGs at 40 CFR 423, means the average of analyses made over a single period of chlorine release which does not exceed two hours.

³ The term “maximum concentration”, as it relates to chlorine discharge under ELGs at 40 CFR 423, means the maximum of analyses made over a single period of chlorine release which does not exceed two hours.

discharge free available or total residual chlorine at any one time unless the utility can demonstrate that the units in a particular location cannot operate at or below this level of chlorination.

ii. Standards of Performance Based on BAT

- (a) There shall be no discharge of polychlorinated biphenyl compounds such as those commonly used for transformer fluid. [40 CFR 423.13(a)]
- (b) Total residual chlorine may not be discharged from any single generating unit for more than two hours per day unless the Discharger demonstrates to the permitting authority that discharges for more than two hours is required for macroinvertebrate control. Simultaneous multi-unit chlorination is permitted. [40 CFR 423.13(b)(2)]
- (c) The quantity of pollutants discharged in cooling tower blowdown shall not exceed the quantity determined by multiplying the flow of cooling tower blowdown times the concentrations listed in Table F-9, below. [40 CFR 423.13(d)(1)]

Table F-9. Cooling Water Blowdown BAT ELGs

| Parameter | Units | 30-day Average Concentration | Daily Maximum Concentration | Average Concentration ² | Maximum Concentration ³ |
|-----------------------------|-------|------------------------------|-----------------------------|------------------------------------|------------------------------------|
| Free Available Chlorine | mg/L | -- | -- | 0.2 | 0.5 |
| Chromium, Total Recoverable | mg/L | 0.2 | 0.2 | -- | -- |
| Zinc, Total Recoverable | mg/L | 1.0 | 1.0 | -- | -- |
| Priority Pollutants | mg/L | ⁴ | ⁴ | -- | -- |

3. Summary of Technology-Based Effluent Limitations

The Facility discharges process waters to the receiving waters via Discharge Points 001, 010, and 020. The total flow volume to the

⁴ No detectable amount of the 126 priority pollutants contained in chemicals added for cooling tower maintenance, as defined in 40 CFR 423, may be discharged from the cooling tower blowdown except for total chromium and total zinc.

receiving water through the outfall is a combination of cooling tower blowdown and in-plant waste streams that consist of low volume waste waters, as defined in 40 CFR 423. 40 CFR 423.12(b)(12) and 423.13(h) states that in the event that waste streams from various sources are combined for treatment or discharge, the quantity of each pollutant or pollutant property attributable to each pollutant waste source shall not exceed the specified limitation for that waste source. In order to ensure that the discharge from each individual waste stream is in compliance with 40 CFR 423, effluent limitations have been established at the discharge of each waste stream before commingling and prior to being discharged through Discharge Point 001. However, because the ELGs for pH contained in 40 CFR 423.12(b)(1) are applicable to all discharges covered under this Order, the technology-based effluent limitations for pH have been applied to the combined discharge.

As discussed in sections IV.B.2.a.i.(b) and IVB.2.a.ii.(a) of this Fact Sheet, 40 CFR 423 establishes ELGs for the discharge of PCBs. However, the Discharger has stated, and the Regional Water Board has confirmed, that there is no potential for PCBs to contaminate effluent discharged from the Facility. Thus, since the ELGs are being applied based on BPJ, and not because the Facility is a fossil fuel or nuclear fuel process generating facility, the Regional Water Board has flexibility in the application of the ELGs. Because it has been determined that there is no potential for PCBs to contaminate the effluent discharged by the Facility, the ELGs for PCBs have not been established in this Order. However, monitoring for PCBs shall be required at least once during this permit term with all other Ocean Plan Table B pollutants, as established in section IV of the MRP.

Effluent limitations in 40 CFR 423.12(b)(11) and 423.13(g) specify that, at the permitting authority's discretion, effluent limitations can be expressed as concentration-based or mass-based. To be consistent with the previous Order, technology-based effluent limitations in this Order are expressed as concentration-based limitations.

This Order establishes the following technology-based effluent limitations at the low volume waste sources discharge point (Monitoring Location M-010) and at the cooling water blowdown discharge point (M-020).

Table F-10. TBELs at Monitoring Locations M-010

| Parameter | Units | Effluent Limitations | | | |
|----------------|-------|----------------------|---------------|-----------------------|-----------------------|
| | | 30-Day Average | Maximum Daily | Instantaneous Minimum | Instantaneous Maximum |
| TSS | mg/L | 30 | 100 | -- | -- |
| Oil and Grease | mg/L | 15 | 20 | -- | -- |
| pH | s.u. | -- | -- | 6.0 | 9.0 |

Table F-11. TBELs at Monitoring Location M-020

| Parameter | Units | Effluent Limitations | | | | | |
|-----------------------------|-------|----------------------|---------------|----------------------|----------------------|-----------------------|-----------------------|
| | | 30-Day Average | Maximum Daily | Average ² | Maximum ³ | Instantaneous Minimum | Instantaneous Maximum |
| Free Available Chlorine | mg/L | -- | -- | 0.2 | 0.5 | -- | -- |
| Chromium, Total Recoverable | mg/L | 0.2 | 0.2 | -- | -- | -- | -- |
| Zinc, Total Recoverable | mg/L | 1.0 | 1.0 | -- | -- | -- | -- |
| Priority Pollutants | mg/L | 4 | 4 | -- | -- | -- | -- |
| pH | s.u. | -- | -- | -- | -- | 6.0 | 9.0 |

Table F-12. TBELs at Monitoring Locations M-001

| Parameter | Units | Effluent Limitations | |
|-----------|-------|-----------------------|-----------------------|
| | | Instantaneous Minimum | Instantaneous Maximum |
| pH | s.u. | 6.0 | 9.0 |

C. Water Quality-Based Effluent Limitations (WQBELs)

1. Scope and Authority

Section 301(b) of the CWA and Section 122.44(d) require that permits include limitations more stringent than applicable federal technology-based requirements where necessary to achieve applicable water quality standards. This Order contains requirements that are necessary to meet applicable water quality standards.

Section 122.44(d)(1)(i) mandates that permits include effluent limitations for all pollutants that are or may be discharged at levels that have the reasonable potential to cause or contribute to an exceedance of a water quality standard, including numeric and narrative objectives within a standard.

As discussed in section II.B of the Fact Sheet, the Facility may discharge at Discharge Point 001 to the Pacific Ocean. A reasonable potential analysis (RPA) was conducted for discharges to the Pacific Ocean according to procedures in the Ocean Plan.

Where reasonable potential has been established for a pollutant, but there is no numeric criterion or objective for the pollutant, WQBELs must be established using: (1) USEPA criteria guidance under CWA Section 304(a), supplemented where necessary by other relevant information; (2) an indicator parameter for the pollutant of concern; or (3) a calculated numeric water quality criterion, such as a proposed state criterion or policy interpreting the state's narrative criterion, supplemented with other relevant information, as provided in Section 122.44(d)(1)(vi).

The process for determining reasonable potential and calculating WQBELs when necessary is intended to protect the designated uses of the receiving water as specified in the Ocean Plan and the Basin Plan, and achieve applicable water quality objectives and criteria that are contained in other state plans and policies, or any applicable water quality criteria contained in the CTR and NTR.

2. Applicable Beneficial Uses and Water Quality Criteria and Objectives

- a. Beneficial Uses.** Beneficial use designations for receiving waters for discharges from the Facility are presented in Finding II.H of the Order and sections III.C.1 and III.C.2 of this Fact Sheet.
- b. Ocean Plan Water Quality Objectives.** Water quality criteria applicable to ocean waters of the Region are established by the Ocean Plan, which includes general provisions and water quality objectives for bacterial characteristics, physical characteristics, chemical characteristics, biological characteristics, and radioactivity. These water quality objectives from the Ocean Plan are incorporated as receiving water limitations into the Order. Table B of the Ocean Plan contains numeric water quality objectives for 83 toxic pollutants for the protection of marine aquatic life and human health. Pursuant to NPDES regulations at 40 CFR 122.44(d)(1), and in accordance with procedures established by the Ocean Plan, the Regional Water Board has performed an Ocean Plan RPA to determine the need for effluent limitations for the Table B toxic pollutants.

c. Basin Plan Water Quality Objectives. In addition to the water quality objectives indicated above, the Basin Plan contains narrative objectives for color, tastes and odors, floating material, suspended material, settleable material, oil and grease, biostimulatory substances, sediment, turbidity, pH, dissolved oxygen, bacteria, temperature, toxicity, pesticides, chemical constituents, and radioactivity that apply to inland surface waters, enclosed bays, and estuaries. For waters designated for use as domestic or municipal supply (MUN), the Basin Plan establishes as applicable water quality criteria the Maximum Contaminant Levels (MCLs) established by the California Department of Public Health for the protection of public water supplies at Title 22 of the California Code of Regulations Section 64431 (Inorganic Chemicals) and Section 64444 (Organic Chemicals).

3. Determining the Need for WQBELs

NPDES regulations at 40 CFR 122.44(d) require effluent limitations to control all pollutants which are or may be discharged at a level which will cause, have the reasonable potential to cause, or contribute to an excursion above any State water quality standard.

a. Ocean Plan RPA

i. Determining Reasonable Potential

Procedures for performing a RPA for ocean dischargers are described in Section III. C. and Appendix VI of the Ocean Plan. In general, the procedure is a statistical method that projects an effluent data set while taking into account the averaging period of water quality objectives, the long term variability of pollutants in the effluent, limitations associated with sparse data sets, and uncertainty associated with censored data sets. The procedure assumes a lognormal distribution of the effluent data set, and compares the 95th percentile concentration at 95 percent confidence of each Table B pollutant, accounting for dilution, to the applicable water quality criterion. The RPA results in one of three following endpoints.

Endpoint 1 – There is “reasonable potential,” and a WQBEL and monitoring are required.

Endpoint 2 – There is “no reasonable potential.” WQBELs are not required, and monitoring is required at the discretion of the Regional Water Board.

Endpoint 3 – The Ocean Plan RPA is inconclusive. Existing WQBELs are retained, and monitoring is required.

The State Water Resources Control Board has developed a reasonable potential calculator, which is available at <http://www.waterboards.ca.gov/plnspols/docs/oplans/rpcalc.zip>. The calculator (RPcalc 2.0) was used in conducting the RPA and considers several pathways in the determination of reasonable potential.

(a) First Path

If available information about the receiving water or the discharge supports a finding of reasonable potential without analysis of effluent data, the Regional Water Board may decide that WQBELs are necessary after a review of such information. Such information may include: the facility or discharge type, solids loading, lack of dilution, history of compliance problems, potential toxic effects, fish tissue data, 303 (d) status of the receiving water, or the presence of threatened or endangered species or their critical habitat, or other information.

(b) Second Path

If any pollutant concentration, adjusted to account for dilution, is greater than the most stringent applicable water quality objective, there is reasonable potential for that pollutant.

(c) Third Path

If the effluent data contains three or more detected and quantified values (i.e., values that are at or above the ML), and all values in the data set are at or above the ML, a parametric RPA is conducted to project the range of possible effluent values. The 95th percentile concentration is determined at 95 percent confidence for each pollutant, and compared to the most stringent applicable water quality objective to determine reasonable potential. A parametric

analysis assumes that the range of possible effluent values is distributed log normally. If the 95th percentile value is greater than the most stringent applicable water quality objective, there is reasonable potential for that pollutant.

(d) Fourth Path

If the effluent data contains three or more detected and quantified values (i.e., values that are at or above the ML), but at least one value in the data set is less than the ML, a parametric RPA is conducted according to the following steps.

- (1) If the number of censored values (those expressed as a “less than” value) account for less than 80 percent of the total number of effluent values, calculate the ML (the mean of the natural log of transformed data) and SL (the standard deviation of the natural log of transformed data) and conduct a parametric RPA, as described above for the Third Path.
- (2) If the number of censored values account for 80 percent or more of the total number of effluent values, conduct a non-parametric RPA, as described below for the Fifth Path. (A non-parametric analysis becomes necessary when the effluent data is limited, and no assumptions can be made regarding its possible distribution.)

(e) Fifth Path

A non-parametric RPA is conducted when the effluent data set contains less than 3 detected and quantified values, or when the effluent data set contains 3 or more detected and quantified values but the number of censored values accounts for 80 percent or more of the total number of effluent values. A non-parametric analysis is conducted by ordering the data, comparing each result to the applicable water quality objective, and accounting for ties. The sample number is reduced by one for each tie, when the dilution-adjusted method detection limit (MDL) is greater than the water quality objective. If the adjusted sample number, after accounting for ties, is greater than 15, the pollutant has no reasonable potential to exceed the water quality objective. If the sample number is 15 or less, the RPA is inconclusive,

monitoring is required, and any existing effluent limitations in the expiring permit are retained.

ii. Reasonable Potential Determination

The following table presents results of the RPA, performed in accordance with procedures described by the Ocean Plan and summarized above. The RPA was conducted using effluent monitoring data generated during monitoring events between November 2002 and September 2010. Consistent with Order No. R-2010-0033 for the Freshwater Tissue Company’s Samoa Pulp Mill, which shares the ocean outfall at Discharge Point 001, the Regional Water Board has granted a dilution ratio of 115:1 at Discharge Point 001, thus a dilution ratio of 115:1 was considered during the RPA.

The RPA endpoint for each Table B pollutant is identified. As shown in the following table, the RPA commonly leads to Endpoint 3, meaning that the RPA is inconclusive, when a majority of the effluent data is reported as ND (not detected). In these circumstances, the Regional Water Board views the “inconclusive” result as an indication of no concern for a particular pollutant; however, additional monitoring will be required for those pollutants during the term of the reissued permit.

The RPA showed “reasonable potential” for total recoverable copper; and therefore an effluent limitation for total recoverable copper is required for discharges to the Pacific Ocean at Discharge Point 001.

Table F-13. Ocean RPA Summary Results

| Table B Pollutant | Most Stringent WQO (µg/L) | No. of Samples | No. of Non-Detects | Max Effluent Conc. (µg/L) | RPA Result, Comment |
|---|---------------------------|----------------|--------------------|---------------------------|--|
| Objectives for Protection of Marine Aquatic Life | | | | | |
| Arsenic | 8 | 2 | 2 | ND | Endpoint 3- RPA is inconclusive. Less than 3 detects or greater than 80% ND. |
| Cadmium | 1 | 2 | 2 | ND | Endpoint 3- RPA is inconclusive. Less than 3 detects or |

| Table B Pollutant | Most Stringent WQO (µg/L) | No. of Samples | No. of Non-Detects | Max Effluent Conc. (µg/L) | RPA Result, Comment |
|--------------------------------------|---------------------------|----------------|--------------------|---------------------------|---|
| | | | | | greater than 80% ND. |
| Chlorinated Phenolics ⁵ | 1 | 2 | 2 | ND | Endpoint 3- RPA is inconclusive. Less than 3 detects or greater than 80% ND. |
| Chromium (VI) | 2 | 20 | 20 | ND | Endpoint 2- An effluent limitation is not required for this pollutant. Monitoring may be required as appropriate. |
| Copper | 3 | 33 | 18 | 8.61 | Endpoint 1- An effluent limitation must be developed for this pollutant. Monitoring is required. |
| Cyanide | 1 | 2 | 2 | ND | Endpoint 3- RPA is inconclusive. Less than 3 detects or greater than 80% ND. |
| Total Chlorine Residual ⁶ | 2 | 30 | 27 | 1.74 | Endpoint 2- An effluent limitation is not required for this pollutant. Monitoring may be required as appropriate. |
| Acute Toxicity | 0.3 (TUa) | 1 | 0 | 0.08 | Endpoint 3- RPA is inconclusive. Less than 3 detects or greater than 80% ND. |
| Chronic Toxicity | 1 (TUc) | 4 | 0 | 0.43 | Endpoint 1- An effluent limitation must be developed for this pollutant. Monitoring is required. |
| Ammonia (as N) | 600 | 1 | 1 | ND | Endpoint 3- RPA is inconclusive. Less than 3 detects or greater than 80% ND. |

⁵ Chlorinated phenolics shall mean the sum of 4-chloro-3-methylphenol, 2-chlorophenol, pentachlorophenol, 2,4,5-trichlorophenol, and 2,4,6-trichlorophenol.

⁶ RPA conducted using Free Chlorine Residual data because previous permit did not require Total Chlorine Residual monitoring.

| Table B Pollutant | Most Stringent WQO (µg/L) | No. of Samples | No. of Non-Detects | Max Effluent Conc. (µg/L) | RPA Result, Comment |
|--|---------------------------|----------------|--------------------|---------------------------|---|
| Endosulfan ⁷ | 0.009 | 3 | 3 | ND | Endpoint 3- RPA is inconclusive. Less than 3 detects or greater than 80% ND. |
| Endrin | 0.002 | 3 | 3 | ND | Endpoint 3- RPA is inconclusive. Less than 3 detects or greater than 80% ND. |
| HCH ⁸ | 0.004 | 3 | 3 | ND | Endpoint 3- RPA is inconclusive. Less than 3 detects or greater than 80% ND. |
| Lead | 2 | 33 | 31 | 0.43 | Endpoint 2- An effluent limitation is not required for this pollutant. Monitoring may be required as appropriate. |
| Mercury | 0.04 | 3 | 3 | ND | Endpoint 3- RPA is inconclusive. Less than 3 detects or greater than 80% ND. |
| Nickel | 5 | 2 | 1 | 0.13 | Endpoint 3- RPA is inconclusive. Less than 3 detects or greater than 80% ND. |
| Non-chlorinated Phenolics ⁹ | 30 | 4 | 4 | ND | Endpoint 3- RPA is inconclusive. Less than 3 detects or greater than 80% ND. |
| Selenium | 15 | 2 | 2 | ND | Endpoint 3- RPA is inconclusive. Less than 3 detects or greater than 80% ND. |
| Silver | 0.7 | 2 | 2 | ND | Endpoint 3- RPA is inconclusive. Less than 3 detects or greater than 80% ND. |

⁷ Endosulfan shall mean the sum of endosulfan-alpha and -beta and endosulfan sulfate.

⁸ HCH shall mean the sum of the alpha, beta, gamma (lindane) and delta isomers of hexachlorocyclohexane.

⁹ Non-chlorinated phenolics shall mean the sum of 2,4-dimethylphenol, 4,6-dinitro-2-methylphenol, 2,4-dinitrophenol, 2-methylphenol, 4-methylphenol, 2-nitrophenol, 4-nitrophenol, and phenol.

| Table B Pollutant | Most Stringent WQO (µg/L) | No. of Samples | No. of Non-Detects | Max Effluent Conc. (µg/L) | RPA Result, Comment |
|---|---------------------------|----------------|--------------------|---------------------------|---|
| Zinc | 20 | 32 | 23 | 6.26 | Endpoint 2- An effluent limitation is not required for this pollutant. Monitoring may be required as appropriate. |
| Objectives for Protection of Human Health – Noncarcinogens | | | | | |
| 1,1,1-Trichloroethane | 540,000 | 2 | 2 | ND | Endpoint 3- RPA is inconclusive. Less than 3 detects or greater than 80% ND. |
| 2,4-Dinitrophenol | 4 | 1 | 1 | ND | Endpoint 3- RPA is inconclusive. Less than 3 detects or greater than 80% ND. |
| 2-Methyl-4,6-Dinitrophenol | 220 | 1 | 1 | ND | Endpoint 3- RPA is inconclusive. Less than 3 detects or greater than 80% ND. |
| Acrolein | 220 | 1 | 1 | ND | Endpoint 3- RPA is inconclusive. Less than 3 detects or greater than 80% ND. |
| Antimony | 1,200 | 2 | 2 | ND | Endpoint 3- RPA is inconclusive. Less than 3 detects or greater than 80% ND. |
| Bis(2-Chloroethoxy) Methane | 4.4 | 1 | 1 | ND | Endpoint 3- RPA is inconclusive. Less than 3 detects or greater than 80% ND. |
| Bis(2-Chloroisopropyl)Ether | 1,200 | 1 | 1 | ND | Endpoint 3- RPA is inconclusive. Less than 3 detects or greater than 80% ND. |
| Chlorobenzene | 570 | 2 | 2 | ND | Endpoint 3- RPA is inconclusive. Less than 3 detects or greater than 80% ND. |
| Chromium (III) | 190,000 | 2 | 2 | ND | Endpoint 3- RPA is inconclusive. Less than 3 detects or greater than 80% ND. |
| Dichlorobenzenes ¹⁰ | 5,100 | 4 | 4 | ND | Endpoint 3- RPA is |

¹⁰ Dichlorobenzenes shall mean the sum of 1,2- and 1,3-dichlorobenzene.

| Table B Pollutant | Most Stringent WQO (µg/L) | No. of Samples | No. of Non-Detects | Max Effluent Conc. (µg/L) | RPA Result, Comment |
|--|---------------------------|----------------|--------------------|---------------------------|--|
| | | | | | inconclusive. Less than 3 detects or greater than 80% ND. |
| Diethyl Phthalate | 33,000 | 1 | 1 | ND | Endpoint 3- RPA is inconclusive. Less than 3 detects or greater than 80% ND. |
| Dimethyl Phthalate | 820,000 | 1 | 1 | ND | Endpoint 3- RPA is inconclusive. Less than 3 detects or greater than 80% ND. |
| Di-n-Butyl Phthalate | 3,500 | 1 | 1 | ND | Endpoint 3- RPA is inconclusive. Less than 3 detects or greater than 80% ND. |
| Ethylbenzene | 4,100 | 2 | 2 | ND | Endpoint 3- RPA is inconclusive. Less than 3 detects or greater than 80% ND. |
| Fluoranthene | 15 | 1 | 1 | ND | Endpoint 3- RPA is inconclusive. Less than 3 detects or greater than 80% ND. |
| Hexachlorocyclopentadiene | 58 | 1 | 1 | ND | Endpoint 3- RPA is inconclusive. Less than 3 detects or greater than 80% ND. |
| Nitrobenzene | 4.9 | 1 | 1 | 0.0083 | Endpoint 3- RPA is inconclusive. Less than 3 detects or greater than 80% ND. |
| Thallium | 2 | 3 | 3 | ND | Endpoint 3- RPA is inconclusive. Less than 3 detects or greater than 80% ND. |
| Toluene | 85,000 | 2 | 2 | ND | Endpoint 3- RPA is inconclusive. Less than 3 detects or greater than 80% ND. |
| Tributyltin | 0.0014 | NA | NA | NA | Endpoint 3- RPA is inconclusive. Less than 3 detects or greater than 80% ND. |
| Objectives for Protection of Human Health – Carcinogens | | | | | |
| 1,1,2,2-Tetrachloroethane | 2.3 | 2 | 2 | ND | Endpoint 3- RPA is inconclusive. Less |

| Table B Pollutant | Most Stringent WQO (µg/L) | No. of Samples | No. of Non-Detects | Max Effluent Conc. (µg/L) | RPA Result, Comment |
|--------------------------------|---------------------------|----------------|--------------------|---------------------------|--|
| | | | | | than 3 detects or greater than 80% ND. |
| 1,1,2-Trichloroethane | 9.4 | 2 | 2 | ND | Endpoint 3- RPA is inconclusive. Less than 3 detects or greater than 80% ND. |
| 1,1-Dichloroethylene | 0.9 | 2 | 2 | ND | Endpoint 3- RPA is inconclusive. Less than 3 detects or greater than 80% ND. |
| 1,2-Dichloroethane | 28 | 2 | 2 | ND | Endpoint 3- RPA is inconclusive. Less than 3 detects or greater than 80% ND. |
| 1,2-Diphenylhydrazine | 0.16 | 1 | 1 | ND | Endpoint 3- RPA is inconclusive. Less than 3 detects or greater than 80% ND. |
| 1,3-Dichloropropylene | 8.9 | 2 | 2 | ND | Endpoint 3- RPA is inconclusive. Less than 3 detects or greater than 80% ND. |
| 1,4 Dichlorobenzene | 18 | 2 | 2 | ND | Endpoint 3- RPA is inconclusive. Less than 3 detects or greater than 80% ND. |
| TCDD Equivalents ¹¹ | 3.9×10^{-9} | 2 | 1 | 1.2×10^{-10} | Endpoint 3- RPA is inconclusive. Less than 3 detects or greater than 80% ND. |
| 2,4,6-Trichlorophenol | 0.29 | 1 | 1 | ND | Endpoint 3- RPA is inconclusive. Less than 3 detects or greater than 80% ND. |
| 2,4-Dinitrotoluene | 2.6 | 1 | 1 | ND | Endpoint 3- RPA is inconclusive. Less than 3 detects or greater than 80% ND. |
| 3,3'-Dichlorobenzidine | 0.0081 | 1 | 1 | ND | Endpoint 3- RPA is inconclusive. Less than 3 detects or greater than 80% ND. |

¹¹ TCDD equivalents shall mean the sum of the concentrations of chlorinated dibenzodioxins (2,3,7,8-CDDs) and chlorinated dibenzofurans (2,3,7,8-CDFs) multiplied by their respective toxicity factors.

| Table B Pollutant | Most Stringent WQO (µg/L) | No. of Samples | No. of Non-Detects | Max Effluent Conc. (µg/L) | RPA Result, Comment |
|----------------------------|---------------------------|----------------|--------------------|---------------------------|--|
| Acrylonitrile | 0.1 | 1 | 1 | ND | Endpoint 3- RPA is inconclusive. Less than 3 detects or greater than 80% ND. |
| Aldrin | 0.000022 | 3 | 3 | ND | Endpoint 3- RPA is inconclusive. Less than 3 detects or greater than 80% ND. |
| Benzene | 5.9 | 2 | 2 | ND | Endpoint 3- RPA is inconclusive. Less than 3 detects or greater than 80% ND. |
| Benzidine | 0.000069 | 1 | 1 | ND | Endpoint 3- RPA is inconclusive. Less than 3 detects or greater than 80% ND. |
| Beryllium | 0.033 | 1 | 1 | ND | Endpoint 3- RPA is inconclusive. Less than 3 detects or greater than 80% ND. |
| Bis(2-Chloroethyl)Ether | 0.045 | 1 | 1 | ND | Endpoint 3- RPA is inconclusive. Less than 3 detects or greater than 80% ND. |
| Bis(2-Ethylhexyl)Phthalate | 3.5 | 2 | 1 | 0.16 | Endpoint 3- RPA is inconclusive. Less than 3 detects or greater than 80% ND. |
| Carbon Tetrachloride | 0.9 | 2 | 2 | ND | Endpoint 3- RPA is inconclusive. Less than 3 detects or greater than 80% ND. |
| Chlordane ¹² | 0.000023 | 3 | 3 | ND | Endpoint 3- RPA is inconclusive. Less than 3 detects or greater than 80% ND. |
| Chlorodibromomethane | 8.6 | 2 | 1 | 0.0035 | Endpoint 3- RPA is inconclusive. Less than 3 detects or greater than 80% ND. |
| Chloroform | 130 | 1 | 1 | ND | Endpoint 3- RPA is inconclusive. Less than 3 detects or |

¹² Chlordane shall mean the sum of chlordane-alpha, chlordane-gamma, chlordene-alpha, chlordene-gamma, nonachlor-alpha, nonachlor-gamma, and oxychlordane.

| Table B Pollutant | Most Stringent WQO (µg/L) | No. of Samples | No. of Non-Detects | Max Effluent Conc. (µg/L) | RPA Result, Comment |
|----------------------------|---------------------------|----------------|--------------------|---------------------------|--|
| | | | | | greater than 80% ND. |
| DDT ¹³ | 0.00017 | 9 | 9 | ND | Endpoint 3- RPA is inconclusive. Less than 3 detects or greater than 80% ND. |
| Dichlorobromomethane | 6.5 | 2 | 1 | 0.011 | Endpoint 3- RPA is inconclusive. Less than 3 detects or greater than 80% ND. |
| Dieldrin | 0.00004 | 3 | 3 | ND | Endpoint 3- RPA is inconclusive. Less than 3 detects or greater than 80% ND. |
| Halomethanes ¹⁴ | 130 | 3 | 3 | ND | Endpoint 3- RPA is inconclusive. Less than 3 detects or greater than 80% ND. |
| Heptachlor | 0.00005 | 3 | 3 | ND | Endpoint 3- RPA is inconclusive. Less than 3 detects or greater than 80% ND. |
| Heptachlor Epoxide | 0.00002 | 3 | 3 | ND | Endpoint 3- RPA is inconclusive. Less than 3 detects or greater than 80% ND. |
| Hexachlorobenzene | 0.00021 | 1 | 1 | ND | Endpoint 3- RPA is inconclusive. Less than 3 detects or greater than 80% ND. |
| Hexachlorobutadiene | 14 | 2 | 2 | ND | Endpoint 3- RPA is inconclusive. Less than 3 detects or greater than 80% ND. |
| Hexachloroethane | 2.5 | 1 | 1 | ND | Endpoint 3- RPA is inconclusive. Less than 3 detects or greater than 80% ND. |
| Isophorone | 730 | 1 | 1 | ND | Endpoint 3- RPA is inconclusive. Less than 3 detects or greater than 80% ND. |
| Methylene Chloride | 450 | 2 | 2 | ND | Endpoint 3- RPA is |

¹³ DDT shall mean the sum of 4,4'DDT, 2,4'DDT, 4,4'DDE, 2,4'DDE, 4,4'DDD, and 2,4'DDD.

¹⁴ Halomethanes shall mean the sum of bromoform, bromomethane (methyl bromide) and chloromethane (methyl chloride).

| Table B Pollutant | Most Stringent WQO (µg/L) | No. of Samples | No. of Non-Detects | Max Effluent Conc. (µg/L) | RPA Result, Comment |
|---------------------------|---------------------------|----------------|--------------------|---------------------------|--|
| | | | | | inconclusive. Less than 3 detects or greater than 80% ND. |
| N-Nitrosodimethylamine | 7.3 | 1 | 1 | ND | Endpoint 3- RPA is inconclusive. Less than 3 detects or greater than 80% ND. |
| N-Nitrosodi-n-Propylamine | 0.38 | 1 | 1 | ND | Endpoint 3- RPA is inconclusive. Less than 3 detects or greater than 80% ND. |
| N-Nitrosodiphenylamine | 2.5 | 1 | 1 | ND | Endpoint 3- RPA is inconclusive. Less than 3 detects or greater than 80% ND. |
| PAHs ¹⁵ | 0.0088 | 11 | 11 | ND | Endpoint 3- RPA is inconclusive. Less than 3 detects or greater than 80% ND. |
| PCBs ¹⁶ | 0.000019 | 3 | 3 | ND | Endpoint 3- RPA is inconclusive. Less than 3 detects or greater than 80% ND. |
| Tetrachloroethylene | 2 | 2 | 2 | ND | Endpoint 3- RPA is inconclusive. Less than 3 detects or greater than 80% ND. |
| Toxaphene | 0.00021 | 3 | 3 | ND | Endpoint 3- RPA is inconclusive. Less than 3 detects or greater than 80% ND. |
| Trichloroethylene | 27 | 2 | 2 | ND | Endpoint 3- RPA is inconclusive. Less than 3 detects or greater than 80% ND. |
| Vinyl Chloride | 36 | 1 | 1 | ND | Endpoint 3- RPA is inconclusive. Less than 3 detects or |

¹⁵ PAHs (polynuclear aromatic hydrocarbons) shall mean the sum of acenaphthylene, anthracene, 1,2-benzanthracene, 3,4-benzofluoranthene, benzo(k)fluoranthene, 1,12-benzoperylene, benzo(a)pyrene, chrysene, dibenzo(a,h)anthracene, fluorene, indeno(1,2,3-cd)pyrene, phenanthrene and pyrene.

¹⁶ PCBs (polychlorinated biphenyls) shall mean the sum of chlorinated biphenyls whose analytical characteristics resemble those of Aroclor-1016, Aroclor-1221, Aroclor-1232, Aroclor-1242, Aroclor-1248, Aroclor-1254 and Aroclor-1260.

| Table B Pollutant | Most Stringent WQO (µg/L) | No. of Samples | No. of Non-Detects | Max Effluent Conc. (µg/L) | RPA Result, Comment |
|-------------------|---------------------------|----------------|--------------------|---------------------------|----------------------|
| | | | | | greater than 80% ND. |

Notes to Table F-12:

ND indicates that the pollutant was not detected.

NA indicates that data was not available.

Minimum probable initial dilution for this discharger is 115:1.

The Maximum Effluent Concentration is the expected concentration after complete mixing, in accordance with reasonable potential procedure in Appendix VI of the Ocean Plan.

iii. WQBEL Calculations

Based on results of the RPA, performed in accordance with methods of the Ocean Plan for discharges to the Pacific Ocean, the Regional Water Board is establishing a WQBEL for total recoverable copper and chronic toxicity for the wastewater discharged through Discharge Point 001. Further, because ELGs have been established for total recoverable chromium, total recoverable zinc, and total chromium, WQBELs for these parameters must be calculated to ensure the technology-based effluent limitations do not allow for exceedances of water quality objectives.

As described by Section III. C of the Ocean Plan, effluent limitations for Table B pollutants are calculated according to the following equation.

$$C_e = C_o + D_m (C_o - C_s)$$

Where

C_e = the effluent limitation (µg/L)

C_o = the concentration (the water quality objective) to be met at the completion of initial dilution (µg/L)

C_s = background seawater concentration (µg/L), with all metals expressed as total recoverable concentrations

Dm = minimum probable initial dilution expressed as parts seawater per part wastewater (here, Dm = 115)

For the Discharger, the calculated minimum probable initial dilution is unchanged from the previous Order (R1-2002-0076). Initial dilution is the process that results in the rapid and irreversible turbulent mixing of wastewater with ocean water around the point of discharge. As site-specific water quality data is not available, in accordance with Table B implementing procedures, Cs equals zero for all pollutants, except the following:

Table F-14. Background Seawater Concentration – Ocean Plan

| Parameter | Background Seawater Concentration (µg/L) |
|------------------|--|
| Arsenic | 3 |
| Copper | 2 |
| Mercury | 0.0005 |
| Silver | 0.16 |
| Zinc | 8 |
| Chronic Toxicity | 0 |

Applicable water quality objectives from Table B of the Ocean Plan are as follows.

Table F-15. Table B Water Quality Objectives

| Parameter | Units | 6-Month Median | 30-Day Average | Daily Maximum | Instantaneous Maximum |
|-----------------------------|-------|----------------|----------------|---------------|-----------------------|
| Copper, Total Recoverable | µg/L | 3 | -- | 12 | 30 |
| Chromium, Total Recoverable | µg/L | 2 | -- | 8 | 20 |
| Lead | µg/L | 2 | -- | 8 | 20 |
| Zinc, Total Recoverable | µg/L | 20 | -- | 80 | 200 |
| Chronic Toxicity | TUc | -- | -- | 1 | -- |

Using the equation, $C_e = C_o + D_m (C_o - C_s)$, concentration based effluent limitations are calculated as follows:

Copper

$$C_e = 3 + 115 (3 - 2) = 118 \text{ µg/L (6-Month Median)}$$

$$C_e = 12 + 115 (12 - 2) = 1,162 \mu\text{g/L (Daily Maximum)}$$
$$C_e = 30 + 115 (30 - 2) = 3,250 \mu\text{g/L (Instantaneous Maximum)}$$

Technology-based effluent limitations prohibit the discharge of priority pollutants contained in chemicals added for cooling tower maintenance with the exception of chromium, and zinc. If copper is used as a chemical for cooling tower maintenance, the technology-based effluent limitation of no discharge of detectable priority pollutants shall be applicable to cooling tower blowdown.

Chromium

$$C_e = 2 + 115 (2 - 0) = 232 \mu\text{g/L (6-Month Median)}$$
$$C_e = 8 + 115 (8 - 0) = 928 \mu\text{g/L (Daily Maximum)}$$
$$C_e = 20 + 115 (20 - 0) = 2,320 \mu\text{g/L (Instantaneous Maximum)}$$

Technology-based effluent limitations of 200 $\mu\text{g/L}$ as a 30-day average and a daily maximum are applicable and are more stringent than the Ocean Plan-based WQBELs.

Lead

$$C_e = 2 + 115 (2 - 0) = 232 \mu\text{g/L (6-Month Median)}$$
$$C_e = 8 + 115 (8 - 0) = 928 \mu\text{g/L (Daily Maximum)}$$
$$C_e = 20 + 115 (20 - 0) = 2,320 \mu\text{g/L (Instantaneous Maximum)}$$

Zinc

$$C_e = 20 + 115 (20 - 8) = 1,400 \mu\text{g/L (6-Month Median)}$$
$$C_e = 80 + 115 (80 - 8) = 8,360 \mu\text{g/L (Daily Maximum)}$$
$$C_e = 200 + 115 (200 - 8) = 22,280 \mu\text{g/L (Instantaneous Maximum)}$$

Technology-based effluent limitations of 1,000 $\mu\text{g/L}$ as a 30-day average and a daily maximum are applicable and are more stringent than the Ocean Plan-based WQBELs.

Chronic Toxicity

$$C_e = 1 + 115 (1 - 0) = 116 \text{ TUc (Daily Maximum)}$$

The technology-based effluent limitations described in section IV.B of this Fact Sheet are more stringent than the respective Ocean Plan WQBELs for those parameters. Thus, technology-based effluent limitations have been established for those parameters.

However, the Ocean Plan requires development of concentration and mass-based WQBEL because there is reasonable potential for Copper. As described in Section III.C of the Ocean Plan, mass-based effluent limitations are calculated as follows:

$$\text{Mass-Based Effluent Limit (lbs/day)} = 0.00834 \times C_e \times Q$$

Where,

- C_e = the effluent limitation ($\mu\text{g/L}$)
- Q = flow rate in million gallons per day (MGD)
- 0.00834 = conversion factor (8.34 if C_e is in mg/L)

Mass-based limitations are established using the facility highest six month median flow of 0.146 MGD. Mass-based limitations for total recoverable copper are summarized below.

Table F-16. Table B Mass-based Effluent Limitations

| Parameter | Units | 6-Month Median | Daily Maximum | Instantaneous Maximum |
|---------------------------|---------|----------------|---------------|-----------------------|
| Copper, Total Recoverable | lbs/day | 0.172 | 1.698 | 4.749 |

As such, flow weighted mass-based effluent limitations for total recoverable copper of 0.172 lbs/day, 1.698 lbs/day, and 4.749 lbs/day are applied to the gross effluent waste stream as a 6-month median, a daily maximum, and an instantaneous maximum respectively, at Monitoring Location M-010. An instantaneous maximum effluent limitation of 3200 $\mu\text{g/L}$ is applied to the combined final effluent at Monitoring Location M-001. By not including mass emission limits, the previous permit incorrectly implemented provision III.C of the Ocean Plan. This permit correctly implements provision III.C of the Ocean Plan by including mass emission limits. Replacement of the previous concentration limits with mass limits does not constitute

backsliding because the mass limits are more restrictive under all historic and foreseeable flows.

WQBELs established by the Order are summarized below. Note that the limitations have been rounded to two significant digits from the calculations above.

**Summary of Ocean Plan Water Quality-based Effluent Limitations
 Discharge Point 001**

**Table F-17. Final WQBELs for Ocean Plan Table B Pollutants for
 Gross Effluent Waste (Monitoring Location M-001)**

| Parameter | Units | 6-Month Median | Daily Maximum | Instantaneous Maximum |
|---------------------------|---------|----------------|---------------|-----------------------|
| Copper, Total Recoverable | µg/L | 118 | 1162 | 3200 ¹⁷ |
| | lbs/day | 0.172 | 1.698 | 4.749 |
| Chronic Toxicity | TUc | --- | 116 | -- |

4. Whole Effluent Toxicity (WET)

Effluent limitations for whole effluent acute and chronic toxicity protect the receiving water from the aggregate effect of a mixture of pollutants that may be present in effluent. There are two types of WET tests – acute and chronic. An acute toxicity test is conducted over a short time period and measures mortality. A chronic test is conducted over a longer period of time and may measure mortality, reproduction, and/or growth.

a. Discharges to the Pacific Ocean (Discharge Point 001)

The Ocean Plan contains numeric water quality objectives for acute and chronic toxicity established in Table B. A RPA for whole effluent chronic toxicity was conducted in accordance with Appendix VI of the Ocean Plan using effluent monitoring data collected during monitoring events in December 2008 and in April 2009 for the wastewater discharged through Discharge Point 001. The test species were *Mytilus sp.* (mussel), *Selanastrum capricornutum* (freshwater algae), *Pimephales promelas* (fathead minnow), and

¹⁷ The previous permit contained a limit of 3200 µg/L, which is retained here because the calculated WQBEL of 3250 µg/L would have required an antidegradation analysis to support a finding for backsliding. Since no analysis was performed, the existing limitation is retained.

Ceriodaphnia dubia (daphnid). A maximum effluent concentration of 1 TUc was observed. The calculator (RPcalc 2.0) was used in conducting the RPA. The results for the RPA indicate that the analysis was inconclusive (Endpoint 3), thus the effluent limitation for chronic toxicity has been carried over for wastewater discharged through Discharge Point 001.

Consistent with the requirements of the Ocean plan, this Order establishes chronic monitoring requirements for effluent at Discharge Point 001. If the result of any chronic toxicity test exceeds the water quality objective, the Discharger must initiate accelerated monitoring as described in section V of the MRP. After accelerated monitoring, if conditions of chronic toxicity are found to persist, the Discharger will be required to conduct a Toxicity Reduction Evaluation (TRE), as described by the MRP. Accelerated toxicity testing and TRE/TIE requirements in the Order are consistent with the previous permit.

Further, this Order establishes a requirement for the Discharger to conduct a screening test using at least one vertebrate, invertebrate, and plant species. After the screening test is completed, monitoring can be reduced to the most sensitive species.

This Order also establishes a new dilution series for WET testing 3.4, 1.75, 0.87, 0.45, and 0.25 because the instream waste concentration (IWC) is approximately 0.87% wastewater and this dilution series brackets the IWC better than the existing Order, which will provide more accurate wet tests. This is consistent with US EPA Regions 9 and 10 Guidance For Implementing Whole Effluent Toxicity Testing Programs, which states in Appendix D "A series of at least five effluent dilutions and a control shall be tested. At minimum, the dilution series shall include and bracket the IWCs." (Emphasis original).

D. Final Effluent Limitations

1. Satisfaction of Anti-Backsliding Requirements

This Order contains restrictions on individual pollutants that are no more stringent than required by the federal CWA. Individual pollutant restrictions consist of technology-based restrictions and water quality-based effluent limitations. The technology-based effluent limitations consist of restrictions on certain pollutants as specified in federal

regulations. The permit's technology-based pollutant restrictions are no more stringent than required by the CWA. Water quality-based effluent limitations (WQBELs) have been scientifically derived to implement water quality objectives that protect beneficial uses. Both the beneficial uses and the water quality objectives have been approved pursuant to federal law and are the applicable federal water quality standards. The scientific procedures for calculating the individual water quality-based effluent limitations are based on the Ocean Plan, which was approved by USEPA on September 15, 2009. All beneficial uses and water quality objectives contained in the Ocean Plan were approved under state law and submitted to and approved by USEPA prior to October 8, 2010. Any water quality objectives and beneficial uses submitted to USEPA prior to October 10, 2010, but not approved by USEPA before that date, are nonetheless "applicable water quality standards for purposes of the CWA" pursuant to Section 131.21(c)(1). Collectively, this Order's restrictions on individual pollutants are no more stringent than required to implement the technology-based requirements of the CWA and the applicable water quality standards for purposes of the CWA.

This Order correctly implements provision III.C of the Ocean Plan by including mass emission limits on the gross effluent discharge, which are new and more stringent than the previous permit. The instantaneous maximum concentration for copper has been retained at 3200 µg/L from the previous permit in order to satisfy antibacksliding rather than modify the limit to 3250 µg/L as determined in the reasonable potential analysis.

The previous permit contained effluent limitations for lead and zinc which were based on the CTR criteria for the protection of marine and aquatic life. Following the protocol in the Ocean Plan, the most stringent effluent concentration limits for lead and zinc would be the 6-Month Median values of 232 and 1400 µg/L, respectively. The MECs for lead and zinc were 50 and 720 µg/L, respectively, based on 34 samples collected between November, 2002, and September, 2011. The lack of reasonable potential for lead and zinc constitutes new information, which permits the removal of effluent limitations consistent with CWA section 402(o)(2)(B). As a result of the RPA, effluent limitations for lead and zinc are not included in the proposed Order and anti-backsliding requirements are satisfied.

The previous permit contained effluent limitations for acute toxicity of aquatic organisms in a format inconsistent with the applicable Ocean Plan procedure for developing such limitations. The previous permit did

not contain monitoring requirements for acute toxicity and the one sample that the Discharger took in 2011 is insufficient to justify removal of the limitation. Instead, this Order correctly implements the Ocean Plan procedure for calculation of effluent limitations in terms of acute toxicity units (TUa) and this Order replaces the previous limitation with 3.75 TUa and anti-backsliding requirements are satisfied.

The effluent limitation for Chronic Toxicity in the previous permit was the result of a miscalculation and represented the 115:1 dilution factor directly as a limit of 115 TUc. This Order correctly calculates the Chronic Toxicity limitation using the Ocean Plan procedure, which results in an effluent limitation of 116 TUc. This minor change to the limitation does not affect the determination of reasonable potential and therefore satisfies antibacksliding requirements.

2. Satisfaction of Antidegradation Policy

This Order is consistent with applicable federal and State antidegradation policies, as it does not authorize the discharge of increased concentrations of pollutants or increased volumes of treated wastewater beyond that which was permitted to discharge in accordance with the previous Order.

3. Stringency of Requirements for Individual Pollutants

This Order contains both technology-based effluent limitations and WQBELs for individual pollutants. The terms of this Order meet the minimum federal technology-based effluent limitations for the Steam Electric Power Generating Point Source Category at 40 CFR 423. The technology-based effluent limitations consist of restrictions on free available chlorine, total recoverable chromium, and total recoverable zinc, total suspended solids, oil and grease, and the remaining priority pollutants as defined in 40 CFR 423. Restrictions on these pollutants are discussed in section IV.B in this Fact Sheet. This Order's technology-based pollutant restrictions implement the minimum, applicable federal technology-based requirements.

WQBELs have been scientifically derived to implement water quality objectives that protect beneficial uses associated with the Pacific Ocean at Discharge Point 001. Both the beneficial uses and the water quality objectives have been approved pursuant to federal law and are the applicable federal water quality standards. The scientific procedures for calculating the individual WQBELs are based on the Ocean Plan, which was approved by USEPA on October 8, 2010. Most beneficial uses

and water quality objectives contained in the Basin Plan were approved under state law and submitted to and approved by USEPA prior to May 30, 2000. Any water quality objectives and beneficial uses submitted to USEPA prior to May 30, 2000, but not approved by USEPA before that date, are nonetheless “applicable water quality standards for purposes of the CWA” pursuant to Section 131.21(c)(1). Collectively, this Order’s restrictions on individual pollutants are no more stringent than required to implement the requirements of the CWA.

In addition, the Regional Water Board has considered the factors in Water Code section 13263, including the provisions of Water Code section 13241, in establishing these requirements.

Summary of Final Effluent Limitations

Discharge Point 001 (while discharging to Pacific Ocean)

Table F-18. Summary of Final Effluent Limitations at Discharge Point 001 (Monitoring Location M-001)

| Parameters | Units | Effluent Limitations | | | | Basis |
|---------------------------|-----------------|----------------------|---------------|-----------------------|-----------------------|----------|
| | | 6-Month Median | Daily Maximum | Instantaneous Minimum | Instantaneous Maximum | |
| Copper, Total Recoverable | µg/L | 118 | 1162 | -- | 3200 | OP |
| | lb/day | 0.172 | 1.698 | -- | 4.749 | |
| pH | s.u. | -- | -- | 6.0 | 9.0 | ELG, BPJ |
| Acute Toxicity | TU _a | -- | 3.75 | -- | -- | OP, PO |
| Chronic Toxicity | TU _c | -- | 115 | -- | -- | OP |

Table F-19 Summary of Final Effluent Limitations at Discharge Point 010 (Monitoring Locations M-010)

| Parameter | Units | Effluent Limitations | | | | | Basis |
|------------------------------|-------|----------------------|----------------|---------------|-----------------------|-----------------------|-------|
| | | 6-Month Median | 30-Day Average | Maximum Daily | Instantaneous Minimum | Instantaneous Maximum | |
| Total Suspended Solids (TSS) | mg/L | -- | 30 | 100 | -- | -- | ELG |
| Oil and Grease | mg/L | -- | 15 | 20 | -- | -- | ELG |
| pH | s.u. | | | | 6.0 | 9.0 | ELG |

Discharge Point 020 (while discharging to Pacific Ocean)

Table F-20. Summary of Final Effluent Limitations at Discharge Point 020

| Parameters | Units | Effluent Limitations | | | | | | Basis |
|-----------------------------------|-------|----------------------|----------------------|-----------------------|-----------------------|-----------------------|-----------------------|-------|
| | | 30-Day Average | Maximum Daily | Average ¹⁸ | Maximum ¹⁹ | Instantaneous Minimum | Instantaneous Maximum | |
| Free Available Chlorine | mg/L | -- | -- | 0.2 | 0.5 | -- | -- | ELG |
| Chromium, Total Recoverable | mg/L | 0.2 | 0.2 | -- | -- | -- | -- | ELG |
| Zinc, Total Recoverable | mg/L | 1.0 | 1.0 | -- | -- | -- | -- | ELG |
| Priority Pollutants ²⁰ | mg/L | No detectable amount | No detectable amount | -- | -- | -- | -- | ELG |
| pH | s.u. | -- | -- | -- | -- | 6.0 | 9.0 | ELG |

E. Interim Effluent Limitations

This section is not applicable.

F. Land Discharge Specifications

This section is not applicable.

G. Reclamation Specifications

This section is not applicable.

¹⁸ The term “average concentration”, as it relates to chlorine discharge under ELGs at 40 CFR 423, means the average of analyses made over a single period of chlorine release which does not exceed two hours (See Attachment A).

¹⁹ The term “maximum concentration”, as it relates to chlorine discharge under ELGs at 40 CFR 423, means the maximum of analyses made over a single period of chlorine release which does not exceed two hours (See Attachment A).

²⁰ Applies to those pollutants contained in chemicals added for cooling tower maintenance except Total Chromium and Total Zinc. Priority pollutants to be monitored shall be identified according to the requirements contained in section IX.A of the MRP.

V. RATIONALE FOR RECEIVING WATER LIMITATIONS

A. Surface Water

CWA section 303(a-c) requires states to adopt water quality standards, including criteria where they are necessary to protect beneficial uses. The Regional Water Board adopted water quality criteria as water quality objectives in the Basin Plan and in the Ocean Plan. The Basin Plan states that “[t]he numerical and narrative water quality objectives define the least stringent standards that the Regional [Water] Board will apply to regional waters in order to protect the beneficial uses.”

The Basin Plan includes numeric and narrative water quality objectives for various beneficial uses and water bodies. This Order contains receiving water limitations for discharges to the freshwater wetland based on the Basin Plan numerical and narrative water quality objectives for biostimulatory substances, bacteria, chemical constituents, color, dissolved oxygen, floating material, oil and grease, pH, pesticides, radioactivity, sediment, settleable material, suspended material, tastes and odors, temperature, toxicity, specific conductance, total dissolved solids, and turbidity.

The Ocean Plan includes numeric and narrative water quality objectives for various beneficial uses. This Order contains receiving water limitations for discharges to the Pacific Ocean based on the Ocean Plan numerical and narrative water quality objectives for dissolved oxygen, floating particulates, oil and grease, pH, discoloration, natural lighting, deposition of solids, dissolved sulfides, organic materials, and nutrient materials.

VI. RATIONALE FOR MONITORING AND REPORTING REQUIREMENTS

Section 122.48 requires that all NPDES permits specify requirements for recording and reporting monitoring results. Water Code sections 13267 and 13383 authorize the Regional Water Board to require technical and monitoring reports. The Monitoring and Reporting Program (MRP), Attachment E of this Order, establishes monitoring and reporting requirements to implement federal and state requirements. The following provides the rationale for the monitoring and reporting requirements contained in the MRP for this Facility.

A. Influent Monitoring

This section is not applicable.

B. Effluent Monitoring

Pursuant to the requirements of 40 CFR 122.44(i)(2) effluent monitoring is required for all constituents with effluent limitations. In addition, routine monitoring of the effluent and the receiving water for priority pollutants is required to periodically assess the reasonable potential of the discharge to cause or contribute to an exceedance of water quality objectives.

Gross effluent monitoring requirements from Order No. R1-2002-0076 for discharges to the Pacific Ocean at Monitoring Location M-001 are retained for total recoverable copper, total recoverable chromium, total recoverable zinc, pH, Table B Pollutants, and acute and chronic toxicity. Routine effluent monitoring has been eliminated for total recoverable lead based on the results of the RPA, which indicated no reasonable potential for lead. Additional monitoring of flow is required on a continuous basis.

This Order requires that the Discharger establish new discharge monitoring locations to determine compliance with effluent limitations for low volume wastes and cooling tower blowdown at Monitoring Locations M-010 and M-020, respectively. Monitoring at these locations is necessary in order to demonstrate compliance with the TBELs established under 40 CFR 423. This MRP establishes new monitoring requirements for Priority Pollutants contained in cooling tower maintenance chemicals at M-020 in order to demonstrate compliance with TBELs contained in this Order.

The Discharger shall establish the following monitoring locations to demonstrate compliance with the effluent limitations, discharge specifications, and other requirements in this Order: M-010 and M-020.

The following describes changes to the effluent monitoring requirements from Order No. R1-2002-0076 established by this Order.

1. Monitoring of the combined low volume waste sources is required in this permit to comply with the TBELs contained in 40 CFR 423 and to assess compliance with the new individual discharge point established by this Order.
2. Flow monitoring has been included to enable calculation of mass emission rates and to track the quantity of wastewater being discharged.
3. Annual monitoring for acute toxicity is included to collect data to support a RPA in future permit renewals.

4. The Gross effluent monitoring frequency for Chronic Toxicity has been increased from annually to quarterly because deficient monitoring for this parameter during the previous permit term resulted in insufficient data to support a reasonable potential analysis.
5. Monitoring for Hexavalent Chromium has been eliminated due to a lack of reasonable potential and no TBELs for this constituent.
6. In accordance with the Ocean Plan, periodic monitoring is required for Table B parameters for which criteria or objectives apply and for which no effluent limitations have been established. In order to provide sufficient monitoring to characterize the effluent and conduct a meaningful RPA during the next permit renewal, this Order establishes one full set of sampling for parameters contained in Table B of the Ocean Plan during the permit term.

C. Whole Effluent Toxicity Testing Requirements

Whole effluent toxicity (WET) limitations and monitoring requirements are included in the Order to protect the receiving water quality from the aggregate effect of a mixture of pollutants in the effluent. Acute toxicity testing measures mortality in 100 percent effluent over a short test period and chronic toxicity testing is conducted over a longer time period and may measure mortality, reproduction, and/or growth. This Order includes an effluent limitation and monitoring requirements for chronic toxicity in discharges to the ocean via Discharge Point 001. The effluent limitation has been carried forward from the existing permit because the available data, when input into the RPA, resulted in Endpoint 3, which is inconclusive. The Discharger did not adequately comply with the monitoring requirements for toxicity in the previous permit resulting in insufficient data for a conclusive RPA. The monitoring frequency has been increased in part to collect more data to support a conclusive RPA and in part as a surrogate to understand potential receiving water impacts of the discharge.

D. Land Discharge Monitoring Requirements

This section is not applicable.

E. Receiving Water Monitoring

This section is not applicable.

F. Other Monitoring Requirements

1. Cooling Tower Maintenance Chemicals

Monitoring for priority pollutants present in cooling tower maintenance chemicals has been established and is required in order to determine compliance with effluent limitations contained in this Order.

VII. RATIONALE FOR PROVISIONS

A. Standard Provisions

Standard Provisions, which apply to all NPDES permits in accordance with section 122.41, and additional conditions applicable to specified categories of permits in accordance with section 122.42, are provided in Attachment D. The Discharger must comply with all standard provisions and with those additional conditions that are applicable under section 122.42.

Section 122.41(a)(1) and (b) through (n) establish conditions that apply to all State-issued NPDES permits. These conditions must be incorporated into the permits either expressly or by reference. If incorporated by reference, a specific citation to the regulations must be included in the Order. Section 123.25(a)(12) allows the state to omit or modify conditions to impose more stringent requirements. In accordance with section 123.25, this Order omits federal conditions that address enforcement authority specified in sections 122.41(j)(5) and (k)(2) because the enforcement authority under the Water Code is more stringent. In lieu of these conditions, this Order incorporates by reference Water Code section 13387(e).

B. Regional Water Board Standard Provisions

In addition to the Federal Standard Provisions (Attachment D), the Discharger shall comply with the Regional Water Board Standard Provisions provided in Standard Provisions VI.A.2 of the Order.

1. Order Provision VI.A.2.a identifies the State's enforcement authority under the Water Code, which is more stringent than the enforcement authority specified in the federal regulations [e.g. 40 CFR sections 122.41(j)(5) and (k)(2)].
2. Order Provision VI.A.2.b requires the Discharger to notify Regional Water Board staff, orally and in writing, in the event that the Discharger does not comply or will be unable to comply with any Order

requirement. This provision requires the Discharger to make direct contact with a Regional Water Board staff person.

3. Order Provision VI.A.2.c requires the Discharger to file a petition with, and receive approval from, the State Water Board Division of Water Rights prior to making any change in the point of discharge, place of use, or purpose of use of treated wastewater that results in a decrease of flow in any portion of a watercourse. This requirement is mandated by Water Code section 1211.

C. Special Provisions

1. Reopener Provisions

- a. **Standard Revisions (Special Provisions VI.C.1.a).** Conditions that necessitate a major modification of a permit are described in 40 CFR 122.62, which include the following:
 - i. When standards or regulations on which the permit was based have been changed by promulgation of amended standards or regulations or by judicial decision. Therefore, if revisions of applicable water quality standards are promulgated or approved pursuant to Section 303 of the CWA or amendments thereto, the Regional Water Board will revise and modify this Order in accordance with such revised standards.
 - ii. When new information that was not available at the time of permit issuance would have justified different permit conditions at the time of issuance.
- b. **Reasonable Potential (Special Provisions VI.C.1.b).** This provision allows the Regional Water Board to modify, or revoke and reissue, this Order if present or future investigations demonstrate that the Discharger governed by this Permit is causing or contributing to excursions above any applicable priority pollutant criterion or objective or adversely impacting water quality and/or the beneficial uses of the receiving waters.
- c. **Whole Effluent Toxicity (Special Provisions VI.C.1.c).** This Order requires the Discharger to investigate the causes of, and identify corrective actions to reduce or eliminate effluent toxicity through a TRE. This Order may be reopened to include a new or revised numeric chronic toxicity limitation, a new acute toxicity limitation, and/or a limitation for a specific toxicant identified in the TRE.

Additionally, if a numeric chronic toxicity water quality objective is adopted by the State Water Quality Board, this Order may be reopened to include a numeric chronic toxicity limitation based on that objective.

2. Special Studies and Additional Monitoring Requirements

a. Toxicity Reduction Requirements (Special Provision VI.C.2.a).

In addition to routine toxicity monitoring, this Order requires the Discharger to submit to the Regional Water Board an Initial Investigative TRE Workplan within 3 months of the effective date of this Order for approval by the Executive Officer, to ensure the Discharger has a plan to immediately move forward with the initial tiers of a TRE, in the event effluent toxicity is encountered. The TRE is initiated by evidence of a pattern of toxicity demonstrated through the additional effluent monitoring provided as a result of an accelerated monitoring program.

The Discharger is required to prepare a TRE Workplan in accordance with appropriate USEPA guidance. Numerous guidance documents are available, as identified below.

- i.** Toxicity Reduction Evaluation Guidance for Municipal Wastewater Treatment Plants, (EPA/833B-99/002), August 1999.
- ii.** Generalized Methodology for Conducting Industrial TREs, (EPA/600/2-88/070), April 1989.
- iii.** Methods for Aquatic Toxicity Identification Evaluations: Phase I Toxicity Characterization Procedures, Second Edition, (EPA 600/6-91/005F), February 1991.
- iv.** Toxicity Identification Evaluation: Characterization of Chronically Toxic Effluents, Phase I, (EPA 600/6-91/005F), May 1992.
- v.** Methods for Aquatic Toxicity Identification Evaluations; Phase II Toxicity Identification Procedures for Samples Exhibiting acute and Chronic Toxicity, Second Edition, (EPA 600/R-92/080), September 1993.
- vi.** Methods for Aquatic Toxicity Identification Evaluations: Phase III Toxicity Confirmation Procedures for Samples Exhibiting Acute and Chronic Toxicity, Second Edition, (EPA 600/R-92/081), September 1993.

vii. Methods for Measuring the Acute Toxicity of Effluents and Receiving Waters to Freshwater and Marine Organisms, Fifth Edition, (EPA 821/R-02/012), October 2002.

viii. Short-term Methods for Estimating the Chronic Toxicity of Effluents and Receiving Waters to Freshwater Organisms, Fourth Edition, (EPA 821/R-02/013), October 2002.

ix. Technical Support Document for Water Quality-based Toxics Control, (EPA 505/2-90/001), March 1991.

3. Best Management Practices and Pollution Prevention

- a. **Pollutant Minimization Plan (Special Provisions VI.C.3.a).** Section VI.C.3.a is included in this Order as required by section 2.4.5 of the SIP. The Regional Water Board includes standard provisions in all NPDES permits requiring development of a Pollutant Minimization Program when there is evidence that a toxic pollutant is present in the effluent at a concentration greater than an applicable effluent limitation.

4. Construction, Operation, and Maintenance Specifications

- a. **Operation and Maintenance (Special Provisions VI.C.4.a and VI.C.4.b).** Section 122.41(e) of 40 CFR requires proper operation and maintenance of permitted wastewater systems and related facilities to achieve compliance with permit conditions. An up-to-date operation and maintenance manual, as required by Provision VI.C.4.b of the Order, is an integral part of a well-operated and maintained facility.

5. Special for Municipal Facilities (POTWs Only)

This section is not applicable.

6. Other Special Provisions

- a. **Solids Disposal and Handling Requirements (Special Provisions VI.C.6.a).** This Order establishes solids disposal and handling requirements to ensure that solids are properly contained prior to disposal that they are disposed at a solid waste facility for which WDRs have been prescribed by the Regional Water Board or in a manner approved by the Executive Officer.

7. Compliance Schedules

This section is not applicable.

VIII. PUBLIC PARTICIPATION

The California Regional Water Quality Control Board, North Coast Region (Regional Water Board) is considering the issuance of waste discharge requirements (WDRs) that will serve as a National Pollutant Discharge Elimination System (NPDES) permit for DG Fairhaven Power, LLC. As a step in the WDR adoption process, the Regional Water Board staff has developed tentative WDRs. The Regional Water Board encourages public participation in the WDR adoption process.

A. Notification of Interested Parties

The Regional Water Board has notified the Discharger and interested agencies and persons of its intent to prescribe WDRs for the discharge and has provided them with an opportunity to submit their written comments and recommendations. Notification was provided through the following posting on the Regional Water Board's Internet site at: http://www.waterboards.ca.gov/northcoast/public_notices/public_hearings/npdes_permits_and_wdrs.shtml and through publication in the Times Standard on.

B. Written Comments

The staff determinations are tentative. Interested persons are invited to submit written comments concerning these tentative WDRs. Comments must be submitted either in person or by mail to the Executive Office at the Regional Water Board at the address above on the cover page of this Order.

To be fully responded to by staff and considered by the Regional Water Board, written comments must be received at the Regional Water Board offices by 5:00 p.m. on **March 9, 2012**.

C. Public Hearing

The Regional Water Board will hold a public hearing on the tentative WDRs during its regular Board meeting on the following date and time and at the following location:

Date: April 26, 2012
Time: 8:30 a.m.
Location: Regional Water Board Office, Board Hearing Room
5550 Skylane Boulevard, Suite A
Santa Rosa, CA 95403

Interested persons are invited to attend. At the public hearing, the Regional Water Board will hear testimony, if any, pertinent to the discharge, WDRs, and permit. Oral testimony will be heard; however, for accuracy of the record, important testimony should be in writing.

Please be aware that dates and venues may change. Our Web address is <http://www.waterboards.ca.gov/northcoast> where you can access the current agenda for changes in dates and locations.

D. Waste Discharge Requirements Petitions

Any aggrieved person may petition the State Water Resources Control Board to review the decision of the Regional Water Board regarding the final WDRs. The petition must be submitted within 30 days of the Regional Water Board's action to the following address:

State Water Resources Control Board
Office of Chief Counsel
P.O. Box 100, 1001 I Street
Sacramento, CA 95812-0100

E. Information and Copying

The Report of Waste Discharge (ROWD), related documents, tentative effluent limitations and special provisions, comments received, and other information are on file and may be inspected at the address above at any time between 8:00 a.m. and 5:00 p.m., Monday through Friday. Copying of documents may be arranged through the Regional Water Board by calling (707) 576-2220.

F. Register of Interested Persons

Any person interested in being placed on the mailing list for information regarding the WDRs and NPDES permit should contact the Regional Water Board, reference this facility, and provide a name, address, and phone number.

G. Additional Information

Requests for additional information or questions regarding this order should be directed to Kason Grady at kgrady@waterboards.ca.gov or (707) 576-2682.

DRAFT



Appendix D – Town of Samoa Wastewater Flow and
Dispersal Area Study
CEC, 2015

DRAFT

DRAFT



California Engineering Company, Inc
Main Office
1110 Civic Center Blvd., Suite 404
Yuba City, CA 95993
530-751-0952 Office
530-751-0953 Fax
www.cecusa.net

Town of Samoa Wastewater Flow and Dispersal Area Study

Waste Water Treatment and Dispersal Facility
Town of Samoa
Humboldt County, Ca.

Owner – Samoa Pacific LLC

Engineer: [California Engineering Company, Inc.](#)

Date: September, 2015

Prepared by: David L. Swartz, PE, PLS, SD, SP

PHASE I – INSTALLATION OF PROPOSED WASTEWATER TREATMENT PLANT AND REPLACEMENT OF EXISTING WASTEWATER COLLECTION SYSTEM

INTRODUCTION

The Town of Samoa is located on the Samoa Peninsula in Humboldt County, California, and is currently owned by the Samoa Pacific Group (SPG). As discussed earlier in this document, the SPG is proposing a three (3) Phased (Phase I, Phase II, and Phase III) rehabilitation and restoration of this existing historic lumber company town and construction of new development.

As part of the overall proposed project, Phase I will entail construction of a new wastewater treatment plant phased construction of a new wastewater collection system along with subsequent removal of the existing wastewater collection system connection to a new wastewater treatment facility, and finally removal of the existing Bark Filters. In addition to a new wastewater collection and transport system and the new wastewater treatment facility, Phase I also proposes to retrofit existing units with low-flow fixtures and construct a new 84 unit multi-family housing unit (MHU). Current projections under Phase I are for the MHU to begin construction concurrently with the new wastewater treatment facility.

While this ROWD is primarily tied to Phase I of this project, the successful completion of Phase I is integral to the success of the full project, as Phase I includes construction of a projected 60% of the wastewater infrastructure required to reach maximum build-out and rehabilitation/revival of the historic town of Samoa.

Projected wastewater flows from Phase I, Phase II and Phase III of this project are summarized in Table 1 below. Details of existing and projected flows are noted below.

Table 1. Summary of projected wastewater flows.

| Project Phase | Existing Average Daily Flow (Gal/day) | Calculated Average Daily Flow (Gal/day) | Design Flow (Gal/day) (Includes Safety Factors) |
|---------------|---------------------------------------|---|---|
| Phase I | 18,977 | 23,902 | 44,650 |
| Phase II | N/A | 21,739 | 44,650 21,739 66,389 |
| Phase III | N/A | 7,200 | 66,389 7,200 73,589 |

* **Note;** Phase I of the Treatment Facility is designed for a flow rate of 44,650 or 87% above the calculated Phase I flow rate to allow for a factor of safety, and to ensure the treatment plant does not violate the 85% capacity rule for expansion.

EXISTING WASTEWATER SYSTEM

Currently, wastewater within the community of Samoa originates from 93 occupied residences, the Samoa Cookhouse Restaurant, a Post Office, Hostelry, a museum, and the Samoa Woman's Club and the Samoa Elementary School.

Primarily based on geography, wastewater flows into one of three wastewater collection, treatment and disposal systems: an Eastern System, a Western System and a School System. The School System's wastewater treatment is independent of the town, is not a part of this project and is therefore, not a part of this ROWD. The Eastern System serves the majority of the town, including the Samoa Cookhouse Restaurant, Woman's Club, Hostelry, and 68 of the existing occupied residences. Within the area serviced by the Eastern System there are 7 dilapidated (vacant) residential units and the gym, neither which currently have sewer service. The Western System serves approximately 25 existing occupied residences located on the west side of the ridge line of the peninsula.

EASTERN SYSTEM

Within the Eastern System, influent from the Cookhouse and the Museum flow into a pump vault located approximately 50 feet northeast of the building. Kitchen waste water flows into a 3,000-gallon grease interceptor prior to reaching the vault. Wastewater is then pumped approximately 750 feet to a 5,000 gallon primary tank located southwest of the Cookhouse. From the 5,000-gallon primary tank, effluent flows into an adjacent 1,500-gallon pump tank and is pumped approximately 650 feet southwest to Bark Filter A. The treatment system at Bark Filter A consists of bark filters and a 15,000-gallon septic tank. In addition to effluent from the Cookhouse, effluent from 16 homes located on Fenwick Street and the Hostelry flow to Bark Filter A. From this location, effluent flows approximately 750 feet southwest to Bark Filter B which consists of additional bark filters and a 25,000-gallon septic tank.

Wastewater from an additional 52 homes and the Woman's Club also flow to Bark Filter B. Effluent from Bark Filter B is pumped to the treatment wetland/pond located within the vicinity of the proposed treatment facility. Additionally, the Eastern System is highly monitored with effluent flow being measured for both quantity and quality. These flow volumes are utilized in the following sections.

WESTERN SYSTEM

The Western System serves approximately 25 residences located on the west side of the ridge line of the peninsula, and is a gravity flow system to a 15,000-gallon septic tank and classic leach trench system.

The Western System is governed by Waste Discharge Requirements Order No. 85-40 adopted by the Regional Board on March 27, 1985. With the permit renewal in 2001 language was incorporated into the order that covers both the Eastern and Western

Systems under Order No. R1-2001-62, ID NO. 1B85017RHUM. Partly as a result of including the Eastern System into this Waste Discharge Requirement Order, the flow volumes and flow characteristics of the Eastern System are quantified and reported. However, because of the age of the Western System and the type of wastewater treatment system, gravity flow to septic tanks and dispersal to leachfield, there are no flow measurements for the Western System.

WWTP Design

DESIGN WASTEWATER FLOW

Design flow rates in this section are based largely on flow volumes and flow characteristics as measured from the Eastern Wastewater Treatment System, which is then extrapolated back to the Western System.

Based on Flow Monitoring Reports for 2014 as reported to the NCRW CB as part of the Waste Discharge Requirements Order No. 85-40 requirements, the Eastern Wastewater Treatment System processes an average of 16,282 gallons influent/day Appendix A. Because there are currently no flow meters on the existing commercial facilities (Cookhouse, Hostlery, Post Office and Museum) EPA industry standards have been utilized to estimate the daily wastewater flow from these facilities (Table 2).

Based on calculations, the daily average wastewater flow for the Eastern System for 2014 (16,282 gpd), minus average daily commercial flow, is 13,876 gpd (Table 2). As discussed earlier, there are a total of 68 residential units currently occupied on the Eastern System. By calculating the average daily influent from those 68 units, based on a measured average daily flow, results in an average daily flow per residence of 204 gpd (Table 2). By utilizing this logic and applying 204 gpd of wastewater generated by each residence serviced by the Western System, the combined residential wastewater flow (Eastern System – 13,876 gpd Western System – 5,101 gpd), is 18,977 gpd.

Due to the age and integrity of the existing system, it is believed that there is significant infiltration of groundwater. In this ROWD, we have worked to normalize flow volumes in an effort to account for infiltration of groundwater. Values utilized in the calculations have been conservatively estimated. As an example, when choosing the loading rates from the EPA Onsite Wastewater Systems Manual, we consistently chose the higher number in the range. Additionally, by using the 2014 wastewater load measurements (Appendix A), we have utilized a low rainfall year. Still, it is considered that the calculated wastewater flow includes approximately 12% infiltration rate.

If we consider that the total measured average daily residential influent flow to be 18,977 gpd and reduce that number by 12%, we have an estimated residential wastewater flow of 16,700 gpd. Spreading that average flow over 93 currently occupied residents provides an average daily wastewater flow of 179.5 or 180 gallons per residence per day.

Table 2. Estimating Existing Flows for both Eastern and Western Systems (Residential/Commercial Use).

| Source of Wastewater | | | Flow Volumes (GPD) |
|---|------------------------|---|-----------------------------------|
| Average Daily Flow | | | 16,282 ¹ |
| Samoa Cookhouse (Breakfast and Lunch) | Est. 100 Customers/day | 14 gal/customer (10 gpd – customer 4 gpd kitchen) | 1,400 ² |
| Post Office (Average 2 employees/day) | | | |
| <i>2 employees/facility/day x 16 gal/employee/day²</i> | | | 32 |
| Museum | | | |
| <i>2 employees/facility/day x 16 gal/employee/day²</i> | | | 32 |
| Hostlery | | | |
| <i>2 employees/facility/day x 16 gal/employee/day²</i> | | | 32 |
| <i>2 customers/bed X 11 beds X 60 gal/customer²</i> | | | 660 |
| <i>Commercial Kitchen</i> | | | 100 |
| Woman’s Club (Estimated Average over 30 days) ³ | | | 150 |
| Average Daily Flow minus Cookhouse, Hostlery, Post Office and Museum | | | 13,876 |
| Number of Residential Units | 68 Homes | 13,876 gpd / 68 residences | 204 gpd/residence |
| Utilizing similar logic for the Western System | | | |
| Number of Residential Units | 25 residence | 204 gpd/residence | 5,101 gal/day |
| Total Existing Average Daily Flows All Structures | | | 18,977 gal/day⁴ |
| Subtracting an estimated 12% for I/I | | | 16,700 |
| Per Residence Calculation (68 eastern + 25 western) | | | 16,700/93 |
| | | | 180 gpd |

1. Based on Average Flow Volumes from the Eastern Treatment System, January, March – December 2014. Note, the Flow Meter broke during the month of February (Appendix A this Volume).
2. Based on Onsite Wastewater Treatment Systems Manual, 2002 Table 3-4.
3. Based on a meeting hall/assembly hall with 75 person capacity X 4 gallons per seat X ½ time use.
4. Average Daily Use includes an estimated 12% (2,330 gpd) of I/I

With this information we can proceed with defining the future estimated average daily flow for the full build-out of Phase I along with the proposed build-out for Phase II and Phase III.

As stated in the Project Description, Phase I encompasses a full revamping of the existing Eastern and Western Wastewater Treatment Systems, with the exception of the recently installed infrastructure for the Samoa Cookhouse and Museum. In addition, Phase I includes an 84-unit multi-family housing unit, and nine new commercial lots. The commercial lots are currently proposed to be small retail stores for the purpose of servicing the residents of the town, and to draw customers/tourists to the peninsula. Table 3 below summarizes the full build-out planned for Phase I of this project while Table 4 summarized the projected full build-out flows.

Table 3. Full Build-out Phase I and Projected Sewer Connection Needs

| Proposed Use | Number of Units | Sewer Connection | |
|--------------------------------------|-----------------|-------------------------------|---------------------------------|
| Residential Low Density (RL) | 102 Lots | es | |
| Residential Medium Density (RM) | 84-units | es | |
| Commercial General (CG) ¹ | 9 Lots | 7 Lots with Sewer Connections | 2 Lots with no sewer connection |
| Public Facilities (PF) | 2 Lots | No Connection | |
| Public Recreation (PR) | 6 Lots | No Connection | |
| Commercial Recreation (CR) | 11 Lots | 3 Lots with Sewer Connections | 8 Lots with-no Sewer Connection |
| Industrial Coastal Dependent (MC) | 2 Lots | No Connections | |
| Natural Resources (NR) | 1 Lot | No Connection | |

1. Includes Cookhouse, Hostelry, Museum, and Woman's Club.

Table 4. Phase I Daily Use Design Calculations – Post Construction of WWTP and Collection System.

| Proposed Use | Number of Units | Daily Average Flow per Lot/Unit | Gallons per day |
|--|---|---|-----------------|
| Residential Low Density (RL) | 102 Lots | 180 ¹ with 25% Flow Reduction Daily Flow is 135 gal/unit/day | 13,770 |
| <i>*Note State mandate 25% savings coupled with revised fixture standards</i> | | | |
| Residential Medium Density (RM) | 84-units | 50 gal/person or 122 gal/unit ² (US Census assumes 2.44 individuals/unit) ^{3*} | 7,686 |
| <i>*Note State mandate 25% water savings coupled with revised fixture standards = 37.5 gal/pp/day or 91.5 gal/unit/day</i> | | | |
| Commercial General (CG) <i>Includes both proposed and existing</i> | 7 Lots with Sewer Connections | 2/employees 10/gal/day/employee ² (20 gpd) 10 customer/day 3 gal/customer ² (30 gpd) | 140 157.5 |
| <i>Cookhouse</i> | Including a 25% Flow Reduction for fixtures | | 1,050 |
| <i>Hostelry</i> | | | 570 |
| <i>Woman's Club</i> | | | 112.5 |
| <i>*Note these values include the State mandate 25% water savings coupled with revised fixture standards</i> | | | |
| Commercial Recreation (CR) | 3 Lots with Connections | 135 gpd/Lot | 405 |
| <i>*Assumed to be similar in flow as a standard unit.</i> | | | |
| Total Average Daily Flow for Phase I at Full Build-out | | | 23,902 |
| <i>This represents a 20.6 % Increase from the current calculated Average Daily Flows.</i> | | | |

1. From Table 2 above.
2. Based on Onsite Wastewater Treatment Systems Manual, 2002 Table 3-4.
3. U.S. Census Data, 2010
4. Based on Onsite Wastewater Treatment Systems Manual, 2002 Table 3-6.

The flow from existing development (pre-construction Phase I) produces approximately 18,977 gal/day. Phase I post-construction flow is offset by the I&I and mandated California State water reductions. The expected flow generated once the new collection system is installed for Phase I is estimated to be 23,902 gal/day, which represents a 20% increase from pre-construction flows (Table 4 above). Table 5 proposes Phase II and Phase III projected daily flows for the proposed build-out of those Phases.

Table 5. Phase II and III Estimated Average Daily Flow Calculations

| Phase II Daily Use Design Calculations: | | | |
|---|----------|-------------------------|----------------|
| Current Use: | | | |
| None | | | |
| Proposed Use: | | Sewer Connection | |
| Residential Low Density (RL): | 105 lots | es | |
| Residential Medium Density (RM): | 62 lots | es | |
| Total Proposed New Residential Lots 167 | | | |
| Average Use: | | | |
| 105 Lots x 135 gal/residence/day | | 14,175 | gal/day |
| 62 Lots x 122 gal/residence/day | | 7,564 | gal/day |
| Total Average Daily Wastewater flow for Phase II | | 21,739 | gal/day |
| Phase III Daily Use Design Calculations: | | | |
| Current Use: | | | |
| None | | | |
| Proposed Use: | | Sewer Connection | |
| Business Park (MB): | 24 lots | es | |
| Average Use: | | | |
| Projected Average daily Use for future business park is 300 gpd/lot | | | |
| 24 Lots x 300 gal/day/lot | | 7,200 | gal/day |
| Total Average Daily Wastewater flow for Phase III | | 7,200 | gal/day |

PEA ING FACTORS:

The peaking factor as defined used herein was derived from the Manual of Water Resources Engineering (Linsley/Franzini, Third Edition).

$$\text{Peaking Factor (PF)} = \frac{\text{peak daily flow rate}}{\text{average daily flow rate}}$$

Typically smaller communities will experience higher peaking factors than larger communities as in smaller communities a relatively small number of persons contributing to a small system can more easily influenced flows. To determine the peaking factor for Samoa, we used data from the 2014 monitoring reports found in Appendix A herein and examined the months of June, July and August, so that I&I would not play a role. From the data flow loggers we determined the following:

Table 6. Summary of projected wastewater flows with Peaking Factors

| Month | Peak G/D | Average G/D | Peak Factor (PF) |
|--------|----------|-------------|------------------|
| June | 15,931 | 11,293 | 1.41 |
| July | 21,216 | 14,825 | 1.43 |
| August | 16,487 | 12,129 | 1.36 |

For this project we have used the highest peaking factor for the three month period observed – 1.43.

Table 7. Peaking Factor as applied to Phase I, Phase II and Phase III

| Project Phase | Calculated Average Daily Flow (Gal/day) | Peaking Factor of 1.43 | Design Flow (Gal/day) (Includes Safety Factors)* |
|-------------------------------------|---|------------------------|--|
| Phase I | 23,902 | 34,179 | 44,650 |
| Phase II | 21,739 | 31,086 | 44,650 21,736 67,195 |
| <i>Phase I + Phase II</i> | | <i>34,179+31,086</i> | <i>65,265</i> |
| Phase III | 7,200 | 10,210 | 67,195 7,140 74,335 |
| <i>Phase I & II + Phase III</i> | | <i>65,26+10,210</i> | <i>75,475</i> |

* Note; The design flow does not change as it remains higher for Phase II and within 3% of Phase III.

The above calculations demonstrate that with the overbuilding of the treatment plant with Phase I, and consistent expansion that the facility design flows are adequate to handle the projected wastewater flow rates through buildout.

DISPERSAL FIELD DESIGN

This leachfield is proposed to be constructed utilizing quick 4 High Capacity Infiltrator Chambers. Leach trenches are proposed to be 36-inches wide spaced 10 feet on center with an average depth of 24-inches. Leachlines are proposed to be 100-feet in length. Based on specification sheets for Infiltrator Chamber the quick 4 - High Capacity Chamber is 34-inches wide at the base and 16-inches high at the crest (Specification Sheet 12 of 18). See Table 8 below for leachfield absorption area calculations.

Table 8. Projected Leachfield Absorption Area Required by Phase

| Phase | Gallons per day | Linear Loading Rate | Absorption Area Required (ft ²) | Acres Require <i>(1 acre = 43,560 ft²)</i> | Number of Zones | Absorption Area (ft ²) <i>(5,000 ft²/zone)</i> | Acres Utilized |
|---|-----------------|---------------------|---|--|-----------------|--|----------------|
| I | 44,650 | 0.69 | 64,710 | 1.48 | 13 | 65,000 | 1.5 |
| II | 21,739 | 0.69 | 31,505 | 0.72 | 10 | 50,000 | 1.4 |
| III | 7,200 | 0.69 | 10,434 | 0.24 | 3 | 15,000 | 0.30 |
| Total Acres Required for full build-out | | | | | | 2.44 | |
| Total Acres Dedicated for full build-out | | | | | | 3.2¹ | |

1. Based on the leachfield lay-out as shown in Figure 1, greater than 3.2 acres have been designated for the required 2.4 acres needed for full build out of this system, providing a greater than 20% safety factor. The entire land designated for wastewater infrastructure is 8.5 acres, which provides for greater than 100% replacement leachfield area.

The master plan dispersal field is shown on Figure 1 herein. A detail of a dispersal field is shown herein on Figure 2. The dispersal fields are color coded to match the Phases of the Project and projected expansions of the WWTP and collection system. The site soils are characterized in Appendix D herein, however are considered to be sand.

PHASE I DISPERSAL Dosing

The WWTP has been designed for a wastewater load of 44,650-gallons. This is projected to provide sufficient safety factor within this system. When looking at the dosing of the leachfields in Phase I, utilizing 44,650-gallons per day and 13 zones. Each zone is projected to receive 3,434-gallons per day. Each zone will have 5 lines, 100 feet in length. With a 0.64 gallon /linear foot void space using 1 1/4 –inch PVC Perforated pipe, each zone will have 140-gallons void space. We propose to dose each zone with 5 times the lateral void space, or 704-gallons/dose. At this dosing volume, each zone will be dosed 6.3 times per day.

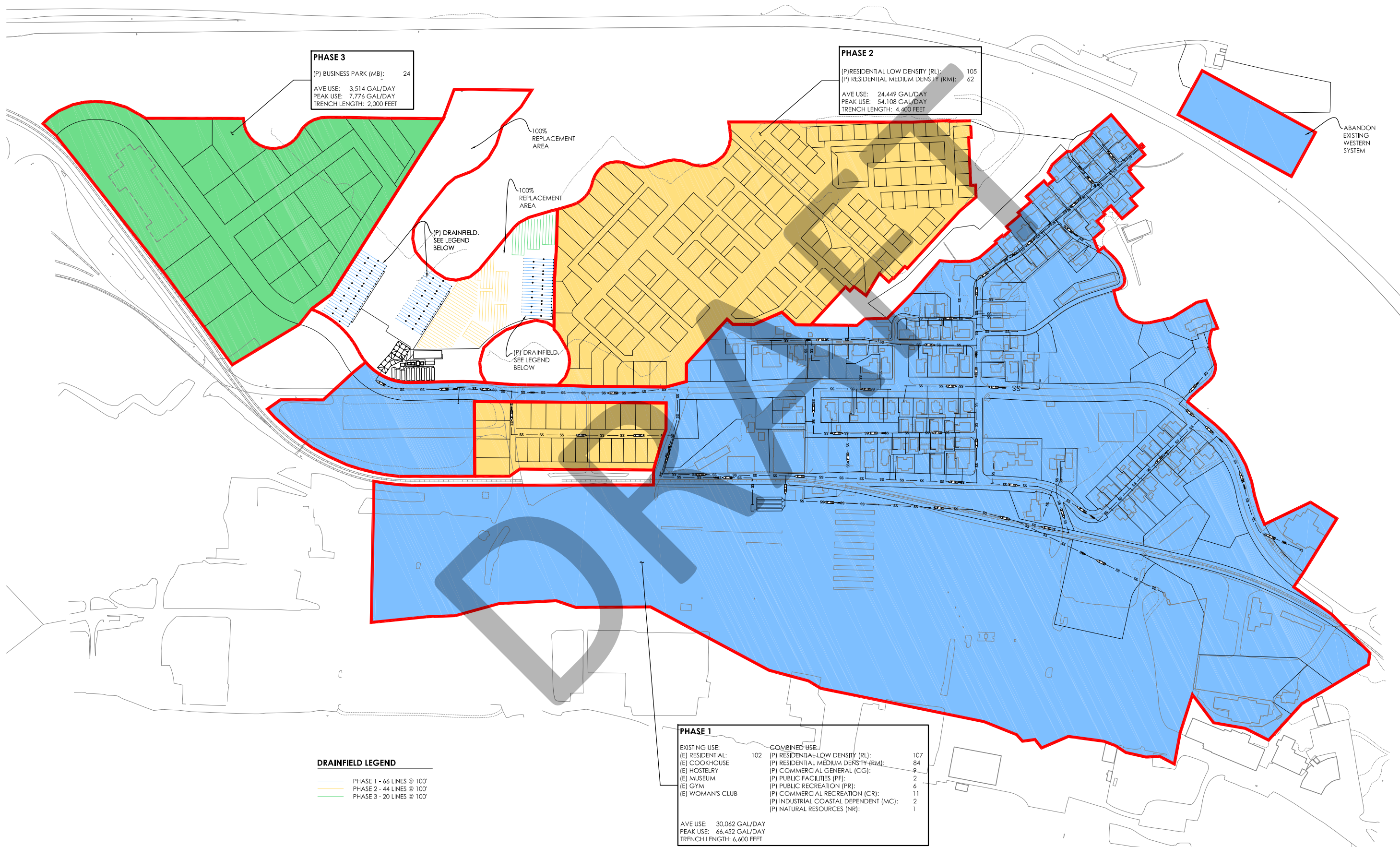

PHASE 3
 (P) BUSINESS PARK (MB): 24
 AVE USE: 3,514 GAL/DAY
 PEAK USE: 7,776 GAL/DAY
 TRENCH LENGTH: 2,000 FEET

PHASE 2
 (P) RESIDENTIAL LOW DENSITY (RL): 105
 (P) RESIDENTIAL MEDIUM DENSITY (RM): 62
 AVE USE: 24,449 GAL/DAY
 PEAK USE: 54,108 GAL/DAY
 TRENCH LENGTH: 4,400 FEET

PHASE 1

| | | |
|----------------------|--|-----|
| EXISTING USE: | COMBINED USE: | |
| (E) RESIDENTIAL: 102 | (P) RESIDENTIAL-LOW DENSITY (RL): | 107 |
| (E) COOKHOUSE | (P) RESIDENTIAL MEDIUM DENSITY (RM): | 84 |
| (E) HOSTELRY | (P) COMMERCIAL GENERAL (CG): | 9 |
| (E) MUSEUM | (P) PUBLIC FACILITIES (PF): | 2 |
| (E) GYM | (P) PUBLIC RECREATION (PR): | 6 |
| (E) WOMAN'S CLUB | (P) COMMERCIAL RECREATION (CR): | 11 |
| | (P) INDUSTRIAL COASTAL DEPENDENT (MC): | 2 |
| | (P) NATURAL RESOURCES (NR): | 1 |

AVE USE: 30,062 GAL/DAY
 PEAK USE: 66,452 GAL/DAY
 TRENCH LENGTH: 6,600 FEET

DRAINFIELD LEGEND

- PHASE 1 - 66 LINES @ 100'
- PHASE 2 - 44 LINES @ 100'
- PHASE 3 - 20 LINES @ 100'

Figure 1

| | | | |
|--|---|--|----------------------|
| PROJECT NUMBER 10-202 | SAMOIA WASTEWATER TREATMENT PLANT REHABILITATION PROJECT WASTEWATER FLOW STUDY TOWN OF SAMOIA, HUMBOLDT COUNTY, CALIFORNIA | DATE: 02-03-2015 SCALE: 1" = 150' DRAWN BY: AV DESIGNED BY: AV CHECKED BY: DLS | NO. DATE DESCRIPTION |
| CEC Engineering - Planning - Surveying - Community Development www.cecusa.net | | Office (530) 751-0952 Fax (530) 751-0953 1110 Civic Center Blvd., Suite 404 Yuba City, CA 95993 | |

California Engineering Company is not responsible for the accuracy or completeness of reproductions of this document generated by others from electronic media.

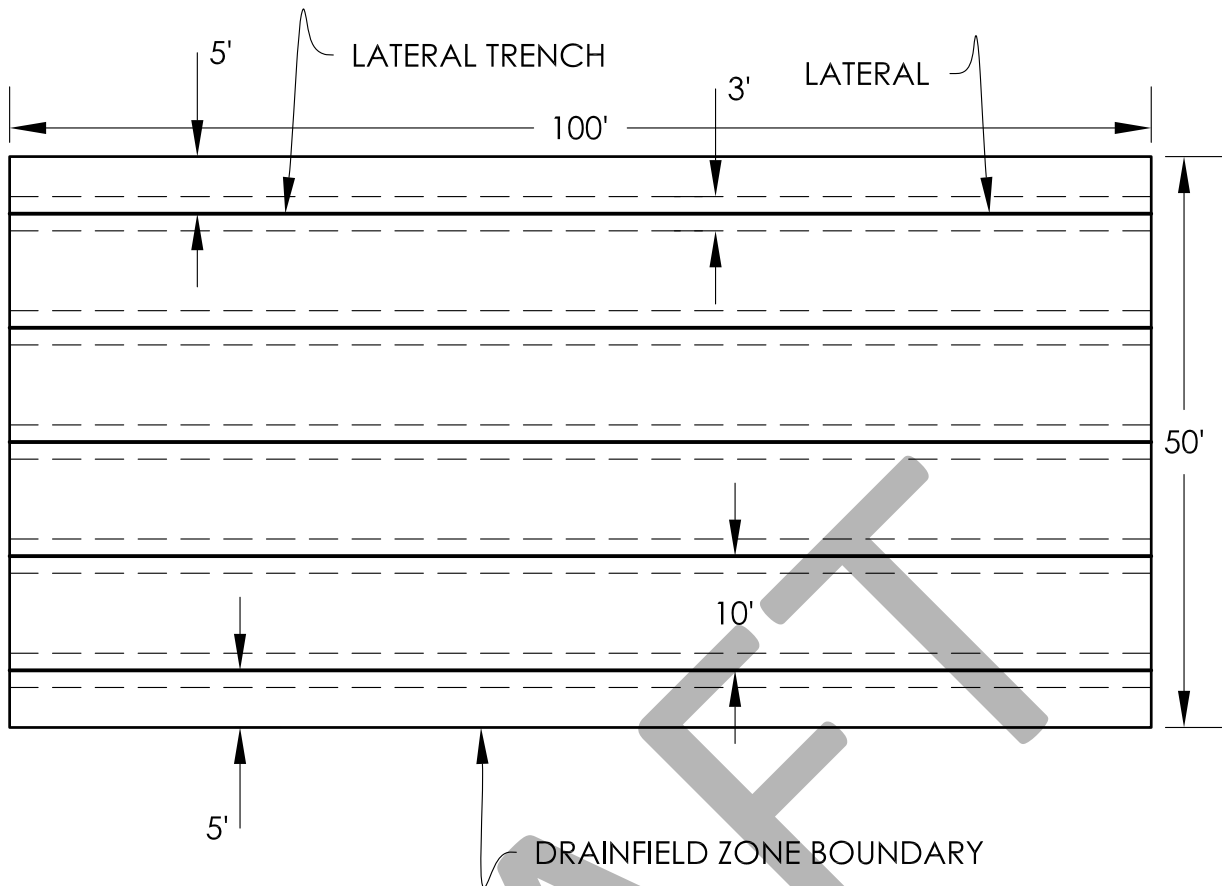

TYPICAL PHASE 1 LOADING CALCULATIONS:

NUMBER OF LATERALS PER ZONE: 5
 LATERAL LENGTH : 100'
 LATERAL SPACING: 10' O.C.
 TRENCH WIDTH: 3'
 NUMBER OF ZONES AT PHASE 1 BUILD OUT: 13

ZONE AREA: 100' X 50' = 5000 SF

EFFLUENT DISCHARGE PER ZONE: $44,650 \div 13 = 3,434.6$ GAL/DAY/ZONE

LOADING RATE ; $3,434.6$ GAL/DAY \div 5000 SF = 0.69 GAL/SF/DAY

Figure 2

DRAINFIELD ZONE EXHIBIT FOR SAMOA PACIFIC GROUP

TOWN OF SAMOA, HUMBOLDT COUNTY, STATE OF CALIFORNIA

MARCH 30, 2015

SHEET 1 OF 1

PREPARED BY: AV

CEC

Office: 530.751.0952
Fax: 530.751.0953
1110 Civic Center Blvd., Ste. 404
Yuba City, CA 95993

Engineering - Planning - Surveying - Community Development
www.cecusa.net

However, using the estimated flows for Phase I of 23,902, which would provide for each of the 13 zones to receive 1,838 gallons per day. With a dose of 704-gallons per dose, that provides each zone with 2.6 doses per day. Additionally, having an equalization pond within the system will allow the dispersal fields to be dosed at variable rates, so as to not over saturate the absorption areas.

DRAFT

















Appendix E – National Primary Drinking Water
Regulations
USEPA

DRAFT

DRAFT

National Primary Drinking Water Regulations



| Contaminant | MCL or TT ¹ (mg/L) ² | Potential health effects from long-term ³ exposure above the MCL | Common sources of contaminant in drinking water | Public Health Goal (mg/L) ² |
|---|--|---|---|--|
|  Acrylamide | TT ⁴ | Nervous system or blood problems; increased risk of cancer | Added to water during sewage/wastewater treatment | zero |
|  Alachlor | 0.002 | Eye, liver, kidney, or spleen problems; anemia; increased risk of cancer | Runoff from herbicide used on row crops | zero |
|  Alpha/photon emitters | 15 picocuries per Liter (pCi/L) | Increased risk of cancer | Erosion of natural deposits of certain minerals that are radioactive and may emit a form of radiation known as alpha radiation | zero |
|  Antimony | 0.006 | Increase in blood cholesterol; decrease in blood sugar | Discharge from petroleum refineries; fire retardants; ceramics; electronics; solder | 0.006 |
|  Arsenic | 0.010 | Skin damage or problems with circulatory systems, and may have increased risk of getting cancer | Erosion of natural deposits; runoff from orchards; runoff from glass & electronics production wastes | 0 |
|  Asbestos (fibers >10 micrometers) | 7 million fibers per Liter (MFL) | Increased risk of developing benign intestinal polyps | Decay of asbestos cement in water mains; erosion of natural deposits | 7 MFL |
|  Atrazine | 0.003 | Cardiovascular system or reproductive problems | Runoff from herbicide used on row crops | 0.003 |
|  Barium | 2 | Increase in blood pressure | Discharge of drilling wastes; discharge from metal refineries; erosion of natural deposits | 2 |
|  Benzene | 0.005 | Anemia; decrease in blood platelets; increased risk of cancer | Discharge from factories; leaching from gas storage tanks and landfills | zero |
|  Benzo(a)pyrene (PAHs) | 0.0002 | Reproductive difficulties; increased risk of cancer | Leaching from linings of water storage tanks and distribution lines | zero |
|  Beryllium | 0.004 | Intestinal lesions | Discharge from metal refineries and coal-burning factories; discharge from electrical, aerospace, and defense industries | 0.004 |
|  Beta photon emitters | 4 millirems per year | Increased risk of cancer | Decay of natural and man-made deposits of certain minerals that are radioactive and may emit forms of radiation known as photons and beta radiation | zero |
|  Bromate | 0.010 | Increased risk of cancer | Byproduct of drinking water disinfection | zero |
|  Cadmium | 0.005 | Kidney damage | Corrosion of galvanized pipes; erosion of natural deposits; discharge from metal refineries; runoff from waste batteries and paints | 0.005 |
|  Carbofuran | 0.04 | Problems with blood, nervous system, or reproductive system | Leaching of soil fumigant used on rice and alfalfa | 0.04 |

LEGEND

 DISINFECTANT

















 DISINFECTION BYPRODUCT

 INORGANIC CHEMICAL

 MICROORGANISM

 ORGANIC CHEMICAL

 RADIONUCLIDES

| Contaminant | MCL or TT ¹ (mg/L) ² | Potential health effects from long-term ³ exposure above the MCL | Common sources of contaminant in drinking water | Public Health Goal (mg/L) ² |
|---|--|---|---|--|
|  Carbon tetrachloride | 0.005 | Liver problems; increased risk of cancer | Discharge from chemical plants and other industrial activities | zero |
|  Chloramines (as Cl ₂) | MRDL=4.0 ¹ | Eye/nose irritation; stomach discomfort; anemia | Water additive used to control microbes | MRDLG=4¹ |
|  Chlordane | 0.002 | Liver or nervous system problems; increased risk of cancer | Residue of banned termiticide | zero |
|  Chlorine (as Cl ₂) | MRDL=4.0 ¹ | Eye/nose irritation; stomach discomfort | Water additive used to control microbes | MRDLG=4¹ |
|  Chlorine dioxide (as ClO ₂) | MRDL=0.8 ¹ | Anemia; infants, young children, and fetuses of pregnant women: nervous system effects | Water additive used to control microbes | MRDLG=0.8¹ |
|  Chlorite | 1.0 | Anemia; infants, young children, and fetuses of pregnant women: nervous system effects | Byproduct of drinking water disinfection | 0.8 |
|  Chlorobenzene | 0.1 | Liver or kidney problems | Discharge from chemical and agricultural chemical factories | 0.1 |
|  Chromium (total) | 0.1 | Allergic dermatitis | Discharge from steel and pulp mills; erosion of natural deposits | 0.1 |
|  Copper | TT ⁵ ; Action Level=1.3 | Short-term exposure: Gastrointestinal distress. Long-term exposure: Liver or kidney damage. People with Wilson's Disease should consult their personal doctor if the amount of copper in their water exceeds the action level | Corrosion of household plumbing systems; erosion of natural deposits | 1.3 |
|  <i>Cryptosporidium</i> | TT ⁷ | Short-term exposure: Gastrointestinal illness (e.g., diarrhea, vomiting, cramps) | Human and animal fecal waste | zero |
|  Cyanide (as free cyanide) | 0.2 | Nerve damage or thyroid problems | Discharge from steel/metal factories; discharge from plastic and fertilizer factories | 0.2 |
|  2,4-D | 0.07 | Kidney, liver, or adrenal gland problems | Runoff from herbicide used on row crops | 0.07 |
|  Dalapon | 0.2 | Minor kidney changes | Runoff from herbicide used on rights of way | 0.2 |
|  1,2-Dibromo-3-chloropropane (DBCP) | 0.0002 | Reproductive difficulties; increased risk of cancer | Runoff/leaching from soil fumigant used on soybeans, cotton, pineapples, and orchards | zero |
|  o-Dichlorobenzene | 0.6 | Liver, kidney, or circulatory system problems | Discharge from industrial chemical factories | 0.6 |
|  p-Dichlorobenzene | 0.075 | Anemia; liver, kidney, or spleen damage; changes in blood | Discharge from industrial chemical factories | 0.075 |
|  1,2-Dichloroethane | 0.005 | Increased risk of cancer | Discharge from industrial chemical factories | zero |

LEGEND



















DISINFECTANT

DISINFECTION
BYPRODUCTINORGANIC
CHEMICAL

MICROORGANISM

ORGANIC
CHEMICAL

RADIONUCLIDES

| Contaminant | MCL or TT ¹ (mg/L) ² | Potential health effects from long-term ³ exposure above the MCL | Common sources of contaminant in drinking water | Public Health Goal (mg/L) ² |
|---|--|---|---|--|
|  1,1-Dichloroethylene | 0.007 | Liver problems | Discharge from industrial chemical factories | 0.007 |
|  cis-1,2-Dichloroethylene | 0.07 | Liver problems | Discharge from industrial chemical factories | 0.07 |
|  trans-1,2-Dichloroethylene | 0.1 | Liver problems | Discharge from industrial chemical factories | 0.1 |
|  Dichloromethane | 0.005 | Liver problems; increased risk of cancer | Discharge from industrial chemical factories | zero |
|  1,2-Dichloropropane | 0.005 | Increased risk of cancer | Discharge from industrial chemical factories | zero |
|  Di(2-ethylhexyl) adipate | 0.4 | Weight loss, liver problems, or possible reproductive difficulties | Discharge from chemical factories | 0.4 |
|  Di(2-ethylhexyl) phthalate | 0.006 | Reproductive difficulties; liver problems; increased risk of cancer | Discharge from rubber and chemical factories | zero |
|  Dinoseb | 0.007 | Reproductive difficulties | Runoff from herbicide used on soybeans and vegetables | 0.007 |
|  Dioxin (2,3,7,8-TCDD) | 0.00000003 | Reproductive difficulties; increased risk of cancer | Emissions from waste incineration and other combustion; discharge from chemical factories | zero |
|  Diquat | 0.02 | Cataracts | Runoff from herbicide use | 0.02 |
|  Endothall | 0.1 | Stomach and intestinal problems | Runoff from herbicide use | 0.1 |
|  Endrin | 0.002 | Liver problems | Residue of banned insecticide | 0.002 |
|  Epichlorohydrin | TT ⁴ | Increased cancer risk; stomach problems | Discharge from industrial chemical factories; an impurity of some water treatment chemicals | zero |
|  Ethylbenzene | 0.7 | Liver or kidney problems | Discharge from petroleum refineries | 0.7 |
|  Ethylene dibromide | 0.00005 | Problems with liver, stomach, reproductive system, or kidneys; increased risk of cancer | Discharge from petroleum refineries | zero |
|  Fecal coliform and <i>E. coli</i> | MCL ⁶ | Fecal coliforms and <i>E. coli</i> are bacteria whose presence indicates that the water may be contaminated with human or animal wastes. Microbes in these wastes may cause short term effects, such as diarrhea, cramps, nausea, headaches, or other symptoms. They may pose a special health risk for infants, young children, and people with severely compromised immune systems. | Human and animal fecal waste | zero⁶ |

LEGEND

















DISINFECTANT

DISINFECTION
BYPRODUCTINORGANIC
CHEMICAL

MICROORGANISM

















ORGANIC
CHEMICAL

RADIONUCLIDES

| Contaminant | MCL or TT ¹ (mg/L) ² | Potential health effects from long-term ³ exposure above the MCL | Common sources of contaminant in drinking water | Public Health Goal (mg/L) ² |
|--|--|---|---|--|
|  Fluoride | 4.0 | Bone disease (pain and tenderness of the bones); children may get mottled teeth | Water additive which promotes strong teeth; erosion of natural deposits; discharge from fertilizer and aluminum factories | 4.0 |
|  <i>Giardia lamblia</i> | TT ⁷ | Short-term exposure: Gastrointestinal illness (e.g., diarrhea, vomiting, cramps) | Human and animal fecal waste | zero |
|  Glyphosate | 0.7 | Kidney problems; reproductive difficulties | Runoff from herbicide use | 0.7 |
|  Haloacetic acids (HAA5) | 0.060 | Increased risk of cancer | Byproduct of drinking water disinfection | n/a⁹ |
|  Heptachlor | 0.0004 | Liver damage; increased risk of cancer | Residue of banned termiticide | zero |
|  Heptachlor epoxide | 0.0002 | Liver damage; increased risk of cancer | Breakdown of heptachlor | zero |
|  Heterotrophic plate count (HPC) | TT ⁷ | HPC has no health effects; it is an analytic method used to measure the variety of bacteria that are common in water. The lower the concentration of bacteria in drinking water, the better maintained the water system is. | HPC measures a range of bacteria that are naturally present in the environment | n/a |
|  Hexachlorobenzene | 0.001 | Liver or kidney problems; reproductive difficulties; increased risk of cancer | Discharge from metal refineries and agricultural chemical factories | zero |
|  Hexachlorocyclopentadiene | 0.05 | Kidney or stomach problems | Discharge from chemical factories | 0.05 |
|  Lead | TT ⁵ ; Action Level=0.015 | Infants and children: Delays in physical or mental development; children could show slight deficits in attention span and learning abilities; Adults: Kidney problems; high blood pressure | Corrosion of household plumbing systems; erosion of natural deposits | zero |
|  <i>Legionella</i> | TT ⁷ | Legionnaire's Disease, a type of pneumonia | Found naturally in water; multiplies in heating systems | zero |
|  Lindane | 0.0002 | Liver or kidney problems | Runoff/leaching from insecticide used on cattle, lumber, and gardens | 0.0002 |
|  Mercury (inorganic) | 0.002 | Kidney damage | Erosion of natural deposits; discharge from refineries and factories; runoff from landfills and croplands | 0.002 |
|  Methoxychlor | 0.04 | Reproductive difficulties | Runoff/leaching from insecticide used on fruits, vegetables, alfalfa, and livestock | 0.04 |
|  Nitrate (measured as Nitrogen) | 10 | Infants below the age of six months who drink water containing nitrate in excess of the MCL could become seriously ill and, if untreated, may die. Symptoms include shortness of breath and blue-baby syndrome. | Runoff from fertilizer use; leaching from septic tanks, sewage; erosion of natural deposits | 10 |















LEGEND



| Contaminant | MCL or TT ¹ (mg/L) ² | Potential health effects from long-term ³ exposure above the MCL | Common sources of contaminant in drinking water | Public Health Goal (mg/L) ² |
|--|---|---|--|---|
|  Nitrite (measured as Nitrogen) | 1 | Infants below the age of six months who drink water containing nitrite in excess of the MCL could become seriously ill and, if untreated, may die. Symptoms include shortness of breath and blue-baby syndrome. | Runoff from fertilizer use; leaching from septic tanks, sewage; erosion of natural deposits | 1 |
|  Oxamyl (Vydate) | 0.2 | Slight nervous system effects | Runoff/leaching from insecticide used on apples, potatoes, and tomatoes | 0.2 |
|  Pentachlorophenol | 0.001 | Liver or kidney problems; increased cancer risk | Discharge from wood-preserving factories | zero |
|  Picloram | 0.5 | Liver problems | Herbicide runoff | 0.5 |
|  Polychlorinated biphenyls (PCBs) | 0.0005 | Skin changes; thymus gland problems; immune deficiencies; reproductive or nervous system difficulties; increased risk of cancer | Runoff from landfills; discharge of waste chemicals | zero |
|  Radium 226 and Radium 228 (combined) | 5 pCi/L | Increased risk of cancer | Erosion of natural deposits | zero |
|  Selenium | 0.05 | Hair or fingernail loss; numbness in fingers or toes; circulatory problems | Discharge from petroleum and metal refineries; erosion of natural deposits; discharge from mines | 0.05 |
|  Simazine | 0.004 | Problems with blood | Herbicide runoff | 0.004 |
|  Styrene | 0.1 | Liver, kidney, or circulatory system problems | Discharge from rubber and plastic factories; leaching from landfills | 0.1 |
|  Tetrachloroethylene | 0.005 | Liver problems; increased risk of cancer | Discharge from factories and dry cleaners | zero |
|  Thallium | 0.002 | Hair loss; changes in blood; kidney, intestine, or liver problems | Leaching from ore-processing sites; discharge from electronics, glass, and drug factories | 0.0005 |
|  Toluene | 1 | Nervous system, kidney, or liver problems | Discharge from petroleum factories | 1 |
|  Total Coliforms | 5.0 percent ⁸ | Coliforms are bacteria that indicate that other, potentially harmful bacteria may be present. See fecal coliforms and <i>E. coli</i> | Naturally present in the environment | zero |
|  Total Trihalomethanes (TTHMs) | 0.080 | Liver, kidney, or central nervous system problems; increased risk of cancer | Byproduct of drinking water disinfection | n/a⁹ |
|  Toxaphene | 0.003 | Kidney, liver, or thyroid problems; increased risk of cancer | Runoff/leaching from insecticide used on cotton and cattle | zero |
|  2,4,5-TP (Silvex) | 0.05 | Liver problems | Residue of banned herbicide | 0.05 |
|  1,2,4-Trichlorobenzene | 0.07 | Changes in adrenal glands | Discharge from textile finishing factories | 0.07 |

LEGEND



| Contaminant | MCL or TT ¹ (mg/L) ² | Potential health effects from long-term ³ exposure above the MCL | Common sources of contaminant in drinking water | Public Health Goal (mg/L) ² | | |
|---|---|--|---|---|---|---|
|  1,1,1-Trichloroethane | 0.2 | Liver, nervous system, or circulatory problems | Discharge from metal degreasing sites and other factories | 0.2 | | |
|  1,1,2-Trichloroethane | 0.005 | Liver, kidney, or immune system problems | Discharge from industrial chemical factories | 0.003 | | |
|  Trichloroethylene | 0.005 | Liver problems; increased risk of cancer | Discharge from metal degreasing sites and other factories | zero | | |
|  Turbidity | TT ⁷ | Turbidity is a measure of the cloudiness of water. It is used to indicate water quality and filtration effectiveness (e.g., whether disease-causing organisms are present). Higher turbidity levels are often associated with higher levels of disease-causing microorganisms such as viruses, parasites, and some bacteria. These organisms can cause short term symptoms such as nausea, cramps, diarrhea, and associated headaches. | Soil runoff | n/a | | |
|  Uranium | 30µg/L | Increased risk of cancer, kidney toxicity | Erosion of natural deposits | zero | | |
|  Vinyl chloride | 0.002 | Increased risk of cancer | Leaching from PVC pipes; discharge from plastic factories | zero | | |
|  Viruses (enteric) | TT ⁷ | Short-term exposure: Gastrointestinal illness (e.g., diarrhea, vomiting, cramps) | Human and animal fecal waste | zero | | |
|  Xylenes (total) | 10 | Nervous system damage | Discharge from petroleum factories; discharge from chemical factories | 10 | | |
| LEGEND |  |  |  |  |  |  |
| | DISINFECTANT | DISINFECTION BYPRODUCT | INORGANIC CHEMICAL | MICROORGANISM | ORGANIC CHEMICAL | RADIONUCLIDES |

NOTES

1 Definitions

- Maximum Contaminant Level Goal (MCLG):** The level of a contaminant in drinking water below which there is no known or expected risk to health. MCLGs allow for a margin of safety and are non-enforceable public health goals.
- Maximum Contaminant Level (MCL):** The highest level of a contaminant that is allowed in drinking water. MCLs are set as close to MCLGs as feasible using the best available treatment technology and taking cost into consideration. MCLs are enforceable standards.
- Maximum Residual Disinfectant Level Goal (MRDLG):** The level of a drinking water disinfectant below which there is no known or expected risk to health. MRDLGs do not reflect the benefits of the use of disinfectants to control microbial contaminants.
- Maximum Residual Disinfectant Level (MRDL):** The highest level of a disinfectant allowed in drinking water. There is convincing evidence that addition of a disinfectant is necessary for control of microbial contaminants.
- Treatment Technique (TT):** A required process intended to reduce the level of a contaminant in drinking water.

2 Units are in milligrams per liter (mg/L) unless otherwise noted. Milligrams per liter are equivalent to parts per million (ppm).

3 Health effects are from long-term exposure unless specified as short-term exposure.

4 Each water system must certify annually, in writing, to the state (using third-party or manufacturers certification) that when it uses acrylamide and/or epichlorohydrin to treat water, the combination (or product) of dose and monomer level does not exceed the levels specified, as follows: Acrylamide = 0.05 percent dosed at 1 mg/L (or equivalent); Epichlorohydrin = 0.01 percent dosed at 20 mg/L (or equivalent).

5 Lead and copper are regulated by a Treatment Technique that requires systems to control the corrosiveness of their water. If more than 10 percent of tap water samples exceed the action level, water systems must take additional steps. For copper, the action level is 1.3 mg/L, and for lead is 0.015 mg/L.

6 A routine sample that is fecal coliform-positive or E. coli-positive triggers repeat samples—if any repeat sample is total coliform-positive, the system has an acute MCL violation. A routine sample that is total coliform-positive and fecal coliform-negative or E. coli-negative triggers repeat samples—if any repeat sample is fecal coliform-positive or E. coli-positive, the system has an acute MCL violation. See also Total Coliforms.

7 EPA's surface water treatment rules require systems using surface water or ground water under the direct influence of surface water to (1) disinfect their water, and (2) filter their water or meet criteria for avoiding filtration so that the following contaminants are controlled at the following levels:

- Cryptosporidium:** 99 percent removal for systems that filter. Unfiltered systems are required to include Cryptosporidium in their existing watershed control provisions.

- Giardia lamblia:** 99.9 percent removal/inactivation
- Viruses:** 99.9 percent removal/inactivation
- Legionella:** No limit, but EPA believes that if *Giardia* and viruses are removed/inactivated, according to the treatment techniques in the surface water treatment rule, *Legionella* will also be controlled.
- Turbidity:** For systems that use conventional or direct filtration, at no time can turbidity (cloudiness of water) go higher than 1 nephelometric turbidity unit (NTU), and samples for turbidity must be less than or equal to 0.3 NTU in at least 95 percent of the samples in any month. Systems that use filtration other than the conventional or direct filtration must follow state limits, which must include turbidity at no time exceeding 5 NTU.
- HPC:** No more than 500 bacterial colonies per milliliter
- Long Term 1 Enhanced Surface Water Treatment:** Surface water systems or ground water systems under the direct influence of surface water serving fewer than 10,000 people must comply with the applicable Long Term 1 Enhanced Surface Water Treatment Rule provisions (e.g. turbidity standards, individual filter monitoring, *Cryptosporidium* removal requirements, updated watershed control requirements for unfiltered systems).
- Long Term 2 Enhanced Surface Water Treatment:** This rule applies to all surface water systems or ground water systems under the direct influence of surface water. The rule targets additional *Cryptosporidium* treatment requirements for higher risk systems and includes provisions to reduce risks from uncovered finished water storages facilities and to ensure that the systems maintain microbial protection as they take steps to reduce the formation of disinfection byproducts. (Monitoring start dates are staggered by system size. The largest systems (serving at least 100,000 people) will begin monitoring in October 2006 and the smallest systems (serving fewer than 10,000 people) will not begin monitoring until October 2008. After completing monitoring and determining their treatment bin, systems generally have three years to comply with any additional treatment requirements.)
- Filter Backwash Recycling:** The Filter Backwash Recycling Rule requires systems that recycle to return specific recycle flows through all processes of the system's existing conventional or direct filtration system or at an alternate location approved by the state.
- 8** No more than 5.0 percent samples total coliform-positive in a month. (For water systems that collect fewer than 40 routine samples per month, no more than one sample can be total coliform-positive per month.) Every sample that has total coliform must be analyzed for either fecal coliforms or E. coli. If two consecutive TC-positive samples, and one is also positive for E. coli or fecal coliforms, system has an acute MCL violation.
- 9** Although there is no collective MCLG for this contaminant group, there are individual MCLGs for some of the individual contaminants:
 - Halooacetic acids:** dichloroacetic acid (zero); trichloroacetic acid (0.3 mg/L)
 - Trihalomethanes:** bromodichloromethane (zero); bromoform (zero); dibromochloromethane (0.06 mg/L)

NATIONAL SECONDARY DRINKING WATER REGULATION

National Secondary Drinking Water Regulations are non-enforceable guidelines regarding contaminants that may cause cosmetic effects (such as skin or tooth discoloration) or aesthetic effects (such as taste, odor, or color) in drinking water. EPA recommends secondary standards to water systems but does not require systems to comply. However, some states may choose to adopt them as enforceable standards.

| Contaminant | Secondary Maximum Contaminant Level |
|------------------------|-------------------------------------|
| Aluminum | 0.05 to 0.2 mg/L |
| Chloride | 250 mg/L |
| Color | 15 (color units) |
| Copper | 1.0 mg/L |
| Corrosivity | Noncorrosive |
| Fluoride | 2.0 mg/L |
| Foaming Agents | 0.5 mg/L |
| Iron | 0.3 mg/L |
| Manganese | 0.05 mg/L |
| Odor | 3 threshold odor number |
| pH | 6.5-8.5 |
| Silver | 0.10 mg/L |
| Sulfate | 250 mg/L |
| Total Dissolved Solids | 500 mg/L |
| Zinc | 5 mg/L |

FOR MORE INFORMATION ON EPA'S
SAFE DRINKING WATER:



visit: epa.gov/safewater



call: (800) 426-4791

ADDITIONAL INFORMATION:

To order additional posters or other ground water and drinking water publications, please contact the National Service Center for Environmental Publications at: **(800) 490-9198**, or email: nscep@bps-lmit.com.



DRAFT



Appendix F – Treatment System Cost Estimates

DRAFT

DRAFT

Capital Costs

Recirculating Gravel Filter

| Item | Quantity | Unit | Unit Cost | Total |
|--|----------|------|-----------|--------------------|
| Site Work | 1 | LS | \$120,000 | \$120,000 |
| Excavation & Disposal | 2280 | CY | \$25 | \$60,000 |
| Concrete | 735 | CY | \$600 | \$440,000 |
| Class II Aggregate Base | 1035 | CY | \$60 | \$60,000 |
| Pressure Treated Filter Frame | 4800 | LF | \$2 | \$10,000 |
| Pea Gravel | 2145 | CY | \$35 | \$80,000 |
| 3/4" Minus Gravel | 1275 | CY | \$35 | \$40,000 |
| Filter Fabric | 2145 | SY | \$5 | \$10,000 |
| Liner | 2145 | SY | \$10 | \$20,000 |
| 2-inch Laterals | 6320 | LF | \$5 | \$30,000 |
| Grates/Access Covers/Misc. Valves | 1 | LS | \$60,000 | \$60,000 |
| Recirculation Pumps | 1 | LS | \$70,000 | \$70,000 |
| Yard Piping | 1 | LS | \$60,000 | \$60,000 |
| Control Building | 1 | LS | \$300,000 | \$300,000 |
| Electrical | 1 | LS | \$180,000 | \$180,000 |
| Construction Subtotal | | | | \$1,540,000 |
| Permitting (5%) | | | | \$80,000 |
| Legal, Administration | | | | \$100,000 |
| Engineering Design and construction phase services (20%) | | | | \$310,000 |
| Geotechnical (5%) | | | | \$80,000 |
| Contingency (20%) | | | | \$310,000 |
| Total | | | | \$2,420,000 |

Sequencing Batch Reactor

| Item | Quantity | Unit | Unit Cost | Total Cost |
|--|----------|------|-----------|--------------------|
| Site Work | 1 | LS | \$100,000 | \$100,000 |
| Bar Screen | 1 | LS | \$300,000 | \$300,000 |
| Grit Removal | 1 | LS | \$200,000 | \$200,000 |
| SBR (FOB Samoa) | 1 | LS | \$300,000 | \$300,000 |
| SBR (installation, including pad) | 1 | LS | \$250,000 | \$250,000 |
| Yard Piping and valves | 1 | LS | \$60,000 | \$60,000 |
| Control Building | 1 | LS | \$300,000 | \$300,000 |
| Electrical | 1 | LS | \$180,000 | \$180,000 |
| Construction Subtotal | | | | \$1,690,000 |
| Permitting (5%) | | | | \$80,000 |
| Legal, Administration | | | | \$100,000 |
| Engineering Design and construction phase services (20%) | | | | \$340,000 |
| Geotechnical (5%) | | | | \$80,000 |
| Contingency (20%) | | | | \$340,000 |
| Total | | | | \$2,630,000 |

Advantex System

| Item | Quantity | Unit | Unit Cost | Total Cost |
|--|----------|------|-------------|--------------------|
| Site work | 1 | LS | \$120,000 | \$120,000 |
| Bar Screen | 1 | LS | \$300,000 | \$300,000 |
| Grit Removal | 1 | LS | \$200,000 | \$200,000 |
| Influent/Effluent Equalization Tank | 2 | LS | \$60,000 | \$120,000 |
| Advantex (FOB Samoa) | 1 | LS | \$2,000,000 | \$2,000,000 |
| Yard Piping and valves | 1 | LS | \$90,000 | \$90,000 |
| Control Building | 1 | LS | \$300,000 | \$300,000 |
| Electrical | 1 | LS | \$180,000 | \$180,000 |
| Construction Subtotal | | | | \$3,310,000 |
| Permitting (5%) | | | | \$170,000 |
| Legal, Administration | | | | \$100,000 |
| Engineering Design and construction phase services (20%) | | | | \$660,000 |
| Geotechnical (5%) | | | | \$170,000 |
| Contingency (20%) | | | | \$660,000 |
| Total | | | | \$5,070,000 |

Reverse Osmosis

| Item | Quantity | Unit | Unit Cost | Total Cost |
|--|----------|------|-----------|--------------------|
| RO System (FOB Samoa) | 1 | LS | \$400,000 | \$400,000 |
| RO System (installation) | 1 | LS | \$150,000 | \$150,000 |
| Building | 1 | LS | \$200,000 | \$200,000 |
| Equalization & Brine Storage Tank | 2 | LS | \$60,000 | \$120,000 |
| Yard Piping and valves | 1 | LS | \$80,000 | \$80,000 |
| Electrical | 1 | LS | \$150,000 | \$150,000 |
| Construction Subtotal | | | | \$1,100,000 |
| Engineering Design and construction phase services (20%) | | | | \$220,000 |
| Geotechnical (5%) | | | | \$60,000 |
| Contingency (20%) | | | | \$220,000 |
| Total | | | | \$1,600,000 |

Ultraviolet Disinfection

| Item | Quantity | Unit | Unit Cost | Total Cost |
|--|----------|------|-----------|------------------|
| Trojan UV System (FOB Samoa) | 1 | LS | \$70,000 | \$70,000 |
| Concrete | 30 | CY | \$700 | \$20,000 |
| Electrical | 1 | LS | \$50,000 | \$50,000 |
| Construction Subtotal | | | | \$140,000 |
| Engineering Design and construction phase services (20%) | | | | \$28,000 |
| Geotechnical (5%) | | | | \$7,000 |
| Contingency (20%) | | | | \$28,000 |
| Total | | | | \$203,000 |

Chlorine Disinfection

| Item | Quantity | Unit | Unit Cost | Total Cost |
|--|----------|------|-----------|------------------|
| Concrete | 50 | CY | \$700 | \$40,000 |
| Gratings, Handrails, and Railings | 1 | LS | \$20,000 | \$20,000 |
| Storage Tanks | 1 | LS | \$75,000 | \$75,000 |
| Metering Pumps | 2 | EA | \$10,000 | \$20,000 |
| Piping, Valves, Diffuser | 1 | LS | \$50,000 | \$50,000 |
| Construction Subtotal | | | | \$205,000 |
| Engineering Design and construction phase services (20%) | | | | \$41,000 |
| Geotechnical (5%) | | | | \$10,000 |
| Contingency (20%) | | | | \$41,000 |
| Total | | | | \$297,000 |

Annual Operation and Maintenance Costs

| Description | SBR | Advantex | RGF | RO | Chlorine | UV |
|--|------------------|------------------|------------------|------------------|----------------|----------------|
| Total Capital Cost | \$2,630,000 | \$5,070,000 | \$2,420,000 | \$1,600,000 | \$297,000 | \$203,000 |
| <i>Labor Cost</i> | | | | | | |
| Number of Operators | 1 | 1 | 1 | 1 | 1 | 1 |
| Weekly Work Hours | 40 | 30 | 20 | 30 | 1 | 1 |
| Hourly Wage | \$40.00 | \$40.00 | \$40.00 | \$40.00 | \$40.00 | \$40.00 |
| Total Annual Labor Cost | \$83,000 | \$62,000 | \$42,000 | \$62,000 | \$2,000 | \$2,000 |
| <i>Power Usage</i> | | | | | | |
| Used Horsepower (hp) | - | 20 | 15 | - | 0 | - |
| Annual Electricity Usage (kWh) | 87,324 | 131,000 | 98,000 | 100,000 | 0 | 8,541 |
| Annual Power Cost | \$11,000 | \$17,000 | \$13,000 | \$13,000 | \$0 | \$1,000 |
| Annual Total Maintenance Cost (2% of capital cost) | \$53,000 | \$101,000 | \$48,000 | \$32,000 | \$6,000 | \$4,000 |
| Total Annual Costs | \$150,000 | \$180,000 | \$100,000 | \$110,000 | \$8,000 | \$7,000 |

DRAFT



Appendix G – EcoCycle SBR Details

DRAFT

DRAFT

| | | | |
|-----------------|--|--------------|------------------|
| To: | Brad Leidecker, P.E. | Date: | 2/15/2018 |
| Company: | Coombs-Hopkins Company | From: | Adam Thiedke |
| Tel.: | 925.948.8987 | | |
| cc: | Kevin Bunting, Brad Linsey, Ron Maiorana | | |
| Subject: | Parkson EcoCycle SBR™ Treatment System, Preliminary Design Proposal for Eureka, CA. | | |

Dear Mr. Leidecker:

Thank you for your interest in Parkson's *EcoCycle SBR™* treatment system. The *EcoCycle SBR™* is an activated sludge treatment process which operates in a batch mode. The SBR process is ideal for organics removal, BNR, and ENR applications. Based upon the data provided for this project, we believe the *EcoCycle SBR™* process is an ideal treatment selection.

A number of equipment options and configurations can be used with the *EcoCycle SBR™*, all of which are designed to meet each project's specific needs. Equipment selections most suitable for each application are dependent on variables such as effluent requirements, O&M costs, energy efficiency, expansion capabilities, and initial capital cost. Parkson welcomes the opportunity to discuss equipment options that will best meet the project requirements.

We appreciate the opportunity to offer our equipment and services for this project. Should you have any questions or need clarifications, please do not hesitate to contact me at (913) 745-1232.™

Sincerely,

PARKSON CORPORATION

An Axel Johnson, Inc. Company

Adam Thiedke

Application Engineer

athiedke@parkson.com



EcoCycle™ SBR

Eureka, CA
Preliminary Design Proposal
February 15, 2018

1. Design Basis

1.1. Influent and Effluent Information

The proposed system design is based on wastewater influent with the following characteristics:

Table 1.1 – Design Influent flow requirements

| PARAMETER | UNITS | AVERAGE |
|------------------------|-------|---------|
| Ave Daily Flow | MGD | 0.200 |
| Peak Daily Flow | MGD | 0.758 |

Table 1.2 - Influent Water Quality

| PARAMETER | UNITS | AVERAGE |
|-------------------------------|-------|---------|
| Max WW Temperature | Deg C | 25 |
| Minimum WW Temperature | Deg C | 12 |
| BOD₅ | mg/L | 250 |
| Total Suspended Solids | mg/L | 250 |
| NH₃-N | mg/L | 33 |
| TKN | mg/L | 50 |
| Total Phosphorous (TP) | mg/L | 7.1 |
| pH | - | 6 to 8 |

Table 1.3 - Effluent Water Quality

| PARAMETER | UNITS | QUALITY |
|-------------------------------|-------|---------|
| BOD₅ | mg/L | 30 |
| Total Suspended Solids | mg/L | 30 |
| NH₃-N | mg/L | NR |
| Total Nitrogen | mg/L | NR |
| Total Phosphorus | mg/L | NR |

A process design spreadsheet has been attached which includes details regarding the process design, equipment sizing calculations, and estimated power costs. The calculations were utilized as the basis for the equipment that has been selected and included in this proposal. The design spreadsheet may include some assumed values that will need to be confirmed as the project moves forward. This proposal is contingent upon the following criteria:

- a. The wastewater will be pretreated to remove debris and grit. Fine screening is recommended.
- b. Sufficient alkalinity is present or will be added to allow uninhibited nitrification and pH of 6.5-8.

- c. The incoming oil and grease is below 100 mg/l.
- d. Chemical and metals concentrations are below toxic thresholds for organics and ammonia removal.
- e. Sufficient nutrients (P, N, micronutrients) are present in the influent for biomass growth or will be added by the plant operating staff.
- f. A qualified operator will supervise plant activities and performance.

2. System Description

The *EcoCycle SBR™* is a fill and draw activated sludge process that operates in a batch mode. The SBR completes all unit process treatment steps within the reactors, eliminating the need for anaerobic or anoxic zones, RAS systems, and secondary clarifiers. The treatment is achieved using 5 primary steps.

2.1. ANOXIC FILL

The SBR tanks are typically operated in series with one tank being filled at any given time. During anoxic fill, the influent valve is opened allowing raw influent to enter the basin. No aeration occurs during this period so that anaerobic and anoxic conditions are present to discourage the growth of filamentous bacteria. The anoxic condition also encourages the growth of well settling, facultative bacteria. Residual nitrate is removed creating anaerobic conditions that promote the growth of VFA's and bio-P bacteria.

During the later part of the anoxic fill, the aeration system is operated to allow the bacteria to begin metabolizing organic matter that was absorbed. This part of the fill period is **AERATED FILL**. SND (Simultaneous Nitrification / Denitrification) occurs during the aerated fill period since both anoxic and aerobic conditions exist. The high oxygen uptake creates an aerated anoxic condition where blowers are operated at full speed yet residual D.O. levels remain near zero.

2.2. REACT

Once the SBR reaches top water level or the designated fill time has been reached, the flow will be diverted to another SBR basin. Aeration and mixing occurs in the reactor until complete biodegradation of organics has occurred. Since no flow enters the basin during react, no short circuiting of raw, untreated waste can occur. Dissolved oxygen (D.O.) is typically monitored during the react phase to determine when residual D.O. starts to form, indicating that oxygen demand for the batch has been satisfied and treatment is completed. Luxury uptake of phosphorous also occurs during the aeration step.

For BNR or ENR applications, the aeration system can be cycled on / off to help promote denitrification. This can be a time based step or can be controlled using instrumentation such as ORP, ammonia analyzers, and nitrate analyzers. Carbon source for nitrate removal and metal salts for P precipitation (if required) are typically added during the un-aerated mix steps near the end of the react period.

2.3. SETTLE

Following react, the SBR will begin a settle mode in which liquids / solids separation occurs. No influent enters the basin during this period allowing for a perfect quiescent condition. All of the reactor volume is used for solids separation. The settle period typically lasts for 45 minutes but is field adjustable through the operator setpoints.

2.4. DECANT

The effluent withdrawal (Decant) begins once the settling period is finished. A floating decanter is used to maximize interface between the withdrawal ports and the settled biomass. The decanter is designed to remove effluent from below the water surface to prevent the inclusion of foam, scum, or floatables. Typical systems will have roughly 25%-35% of the basin contents removed from the upper portion of the reactor during the decant period.

2.5. IDLE

The final step in the treatment process is the idle period. During idle, waste activated sludge is typically removed to maintain the correct biomass population in the reactor. The aeration and mixing system are typically not operated during idle and the reactor simply waits for the next cycle to begin. An option to aerate during extended idle periods is provided through the control system.

3. System Components / Features

3.1. Flow Control Manifold (FCM)

A Flow Control Manifold (FCM) is used to bring raw wastewater into the SBR reactor. The FCM is typically located with the bottom of the manifold 6" above the floor with a series of openings facing the floor. Raw influent is fed through the FCM which insures intimate contact between the raw influent and the settled biomass. The FCM also allows the influent to enter at a low velocity so the settled biomass is undisturbed in cases where fill and decant may occur simultaneously (such as during high sustained peaks and single tank operation). This same manifold is also used for multipoint sludge collection during the waste sludge step in some cases.

3.2. Floating Decanter

The Parkson *DynaCanter™* is a floating style decanter which utilizes a flex joint to allow vertical articulation. The decanter collects treated effluent from 16"-24" below the water surface to preclude foam, scum, or other floatables from the effluent. A series of check valves are provided in the decanter draw tube to isolate the effluent piping from the mixed liquor during mixing and aeration steps. A standard open / close valve is used in the effluent piping to control flow rate through the decanter. No

electromechanical components are used inside the basin making operation and maintenance convenient for the operator.



3.3. DynaPhase Controls™

The Parkson *DynaPhase Controls™* use constant level measurement analysis to determine rate of influent flows and adjusts treatment steps accordingly. During high flow events, this unique feature allows the system to dynamically adjust treatment steps based on actual flow rather than toggling between a normal mode and a storm mode. For example, if the plant is experiencing a 1.75X peaking factor, the control system will automatically cater cycle length and structure based on this specific flow. The *DynaPhase Controls™* also include a first response feature in which the control system will automatically take a tank off line in the event of a primary equipment failure.

4. Equipment and Services Provided

Flow Control Manifolds: Two (2) Model FCM6-600 Manifolds shall be provided. Manifolds will be constructed of FRP with 304 stainless steel supports. Manifolds shall include adequate number and size of openings to reduce inlet velocities to <0.5 fps.

Fixed Diffusers: Two (2) Fixed Fine Bubble Diffuser Systems shall be provided. Each system shall consist of disk type membrane diffusers, PVC manifold piping, 304 stainless steel supports and

304 stainless steel air drop pipe. All in-basin air piping between air drops (including supports) shall be provided by the Contractor.

Decanters: Two (2) Model ED6-700 *DynaCanter™* Floating, Effluent Decanters shall be provided. Each decanter shall include 304 stainless steel supports and in-basin discharge piping. The in-basin discharge piping of the decanter shall terminate with a 6" flange for connection to the flanged wall penetration supplied by others.

Blowers and Accessories: Two (2) Rotary Positive Displacement Blowers (one as a standby) shall be provided. Each blower will be selected to deliver 218 SCFM at 9.2 PSIG. Each blower will be furnished complete with inlet filter, inlet silencer, discharge silencer, butterfly valve, check valve, pressure relief valve, base plate, V-belt with sheaves, and a 15 Hp, 1800 RPM, 460 volt, 3 ph, 60 hz, TEFC motor. Sound Enclosures are not included.

Waste Sludge Pumps: Two (2) Submersible Centrifugal Pumps shall be provided for sludge wasting. Each pump will be selected to deliver 250 GPM at a total pump head of 15 ft. Each pump will be furnished complete with elbow discharge connection, 30 ft. power cable, thermal overload / seal failure protection, retrieval guide rails and guide rail brackets, stainless steel lifting cable, and a 5.0 Hp, 460 volt, 3 ph, 60 hz, submersible motor.

Valves: Valves shall be furnished as listed below. All automatic valves will have 120 volt single phase electric motor actuators.

| Function | Quantity | Size | Type | Operator |
|----------|----------|------|-----------|----------|
| Influent | 2 | 6" | Plug | Electric |
| Effluent | 2 | 6" | Butterfly | Electric |
| Air | 2 | 4" | Butterfly | Electric |

FRP Field Weld Material: FRP field wrap kits shall be provided to complete FRP field welds as identified on Parkson's submittal drawings. Kits shall include FRP mat and woven roving, resin, catalyst, and gel coat. Labor for completing field joints shall be by the installing contractor.

Supports: Supports for the in-basin equipment supplied by Parkson and described in this proposal are included. Supports will be constructed of 304 Stainless Steel. Field welding of supports shall be by the installing contractor.

Hardware: Anchor bolts, gaskets, and connecting hardware for mounting in-basin equipment supplied by Parkson are included. Anchor bolts and connecting hardware shall be 18-8 SS.

Note: Hardware and gaskets at Parkson/Contractor interfacing flanged connections are not included and shall be provided by the installing contractor.

Process Control Panel: A control panel capable of directing operation of components listed in this proposal shall be provided. Control features shall include the following:

- NEMA 12 Enclosure
- Analog I/O modules as required
- Digital I/O modules as required

- 10% spare I/O of each type
- Allen Bradley PLC
- Operator Interface
- Control / Monitoring of Proposed Equipment and Instrumentation
- HOA / OCA Switches
- LED Lights
- Modem
- Submersible Pressure Transducers for Each SBR Basin (including stilling well)
- Emergency TWL Float
- *DynaPhase Controls™* Software

On-Site Service: Field service shall be provided for dry inspection, wet start up, O&M training, and follow up training. A total of four (4) trips / twelve (12) man days of service are included. Additional service can be provided at Parkson’s daily field service rates.

Submittals and O&M Manuals: Submittals and O&M Manuals shall be provided as required by the project specifications.

5. Cost Estimate and Terms

Budget price for equipment and services.....\$ _____

Freight terms are FOB jobsite, offloading by others.

Taxes are not included.

Terms are 10% Submittals, 80% Shipment, 10% Start up (NTE 180 days from Shipment).

Approval drawings: 6-10 weeks after receipt of written order.*

Equipment Shipment: 16-20 weeks after complete release for manufacture.*

*Schedules will be verified at time of Order.

6. Clarifications / Exclusions

Decanter wall spools must be cast in place or supported with additional bracing if link seals are used.

All equipment is quoted with manufacturer’s standard coatings.

Influent concentrations have been assumed, and are to be confirmed.

Chemical feed equipment has not been included. Any requirements for addition of metal salts, carbon source, alkalinity, nutrients, or micronutrients shall be by others.

If blower sound enclosures are used, contractor shall be responsible for providing 120 volt power source if required.

This proposal is based on providing Parkson's standard SBR control program. Additional programming for other equipment or upgrades to standard hardware formats can be provided at additional cost. SCADA / PC graphics packages are available if not already included in this proposal.

Hoists for submersible pumps shall be provided by others.

A minimum of 3.5 ft of static head differential (plus pipe friction losses) between SBR BWL and water level at discharge elevation must be provided for the decanter to function properly. Outlet at effluent pipe discharge must be constantly submerged or provided with an upturned elbow to prevent air from entering the effluent piping.

Out of basin air and liquid piping are not included. In basin air piping between air drops (if used) is by others.

Concrete must be designed to accommodate 6" anchor bolts.

Unless specified in the controls section of this proposal, valve power through the SBR control panel has not been included.

Contractor/Owner shall be responsible for providing freeze protection.

All welding shall be per AWS standards only (ASME standards, if required, may result in additional cost).

MCC, VFD's, and motor starters are by others.

7. Supplemental Information and References (Attachments)

EcoCycle SBR™ design Calculations



EcoCycle SBR™ Sequencing Batch Reactor (SBR) Design Outline

Eureka, CA
Future Flow

Designer: A. Thiedke
Date: 2/15/2018

| | | | |
|------------|-------|-------------|-------------------------|
| Flow (ADF) | 0.200 | MGD average | 757 m ³ /d |
| Flow (PDF) | 0.758 | MGD | 2,869 m ³ /d |

| INFLUENT CHARACTERISTICS | | | |
|--------------------------|------|-------|------|
| | mg/l | lbs/d | kg/d |
| * BOD | 250 | 417 | 189 |
| * COD | 438 | 730 | 331 |
| * TSS | 250 | 417 | 189 |
| * TKN | 50 | 83 | 38 |
| * NH4-N | 33 | 56 | 25 |
| * TN | 50 | 83 | 38 |
| * P | 7.1 | 12 | 5 |
| * TDS | 500 | 834 | 378 |
| * Inert TSS fraction | | 40 % | |

| EFFLUENT REQUIREMENTS | | | |
|---|------|-------|------|
| | mg/l | lbs/d | kg/d |
| BOD | 30 | 50 | 22.7 |
| COD | NR | NR | NR |
| TSS | 30 | 50 | 22.7 |
| TKN | NR | NR | NR |
| NH3-N Sum | NR | NR | NR |
| NH3-N Win | NR | NR | NR |
| TN | NR | NR | NR |
| ** P | NR | NR | NR |
| ** Alum or ferric chloride addition req'd | | | |

| SITE CONDITIONS | | |
|------------------------------|-------------|---------|
| Winter WW Temperature (min.) | 12 °C | 54 °F |
| Summer WW Temperature (max) | 25 °C | 77 °F |
| Average WW Temperature | 18.5 °C | 65 °F |
| Elevation | 40 ft | 12 m |
| Average barometric pressure | 14.67 psia* | 101 kPa |
| Winter Air Temperature | -12 °C | 10 °F |
| Summer Air Temperature | 38 °C | 100 °F |

| PROCESS DESIGN PARAMETERS | | | |
|---|------------------|----------------------|--------------------|
| Design MLSS | 2,900 mg/l @ TWL | | |
| Design MLSS | 4,060 mg/l @ BWL | | |
| Hydr. Retention Time provided | 0.88 days | 21.0 hours | |
| Aerobic Sludge Age (SRT _{ox}) | 6.0 days | | |
| System SRT | 12.0 days | | |
| Biosolids growth rate | 0.22 | gVSS/gCODr/d | |
| | 0.45 | gVSS/gBODr/d | |
| F:M (adjusted for aeration %) | 0.34 | gCOD/gMLSS/d | |
| | 0.20 | gBOD/gMLSS/d | |
| System F:M | 0.10 | gBOD/gMLSS/d | |
| Avg biosolids yield | 180 | lbs./day* | 82 kg/d |
| Avg net sludge yield (bio+inerts) | 304 | lbs/d based on CODr* | 138 kg/d |
| | 353 | lbs/d based on BODr* | 160 kg/d |
| Mass aerobic MLSS req'd | 2,117 | lbs | 960 kgs |
| Mass aerobic volume req'd | 0.09 | MG | 331 m ³ |
| Aerated portion of day | 50.0 | % | |
| Required total SBR volume | 0.18 | MG | 663 m ³ |

BASIN DIMENSIONS

| | | |
|--------------------------------|-----------|--------------------|
| Number of SBR basins | 2 | |
| Rectangular Dimensions: | | |
| Length/Width Ratio | 2.0 : 1 | |
| Length | 36 ft. | 11.0 m |
| Width | 18 ft. | 5.5 m |
| Round Dimensions | | |
| Diameter | 29 ft. | 8.77 m |
| Top Water Level | 18.0 ft. | 5.49 m |
| Bottom Water Level | 12.9 ft. | 3.92 m |
| TWL at Design Average Flow | 18.0 ft. | 5.49 m |
| Total Volume in SBR's | 0.18 MG | 663 m ³ |
| Total Retention Time in SBR | 21.0 hrs. | |

AERATION SYSTEM SIZING

First Estimate :

| | | | | |
|--|-------|--------------------------|------------------------------------|------|
| lbs. O ₂ /lb. BOD removed | 1.25 | | kg O ₂ /kg BOD removed | |
| lbs. O ₂ /lb. TKN oxidized | 4.6 | | kg O ₂ /kg TKN oxidized | |
| lbs. O ₂ /lb. NO ₃ x denitrified | -2.86 | | | |
| Denitrification credit | 0 % | | | |
| Actual Oxygen Req'd, AOR | 795 | lbs. O ₂ /day | 360 | kg/d |

Second Estimate :

$$AOR = COD_i - COD_w - COD_{es} + 4.6 * TKN_{ox} - 2.86 * NO_3N_{dn}$$

| | | | | |
|---------|---|---|--------------|----------|
| where : | COD _i influent | = | 730 lbs./day | 331 kg/d |
| | COD _w wasted | = | 216 lbs./day | 98 kg/d |
| | COD _{es} eff soluble | = | 133 lbs./day | 61 kg/d |
| | TKNox** oxidized | = | 64 lbs./day | 29 kg/d |
| | NO ₃ N _{dn} denitrified | = | 0 lbs./day | 0 kg/d |
| | Mass balance AOR | | 674 lbs./day | 306 kg/d |

Use highest estimate DESIGN AOR = 795 lbs/day 360 kg/d

Conversion Formula from ASCE Manual of Practice :

$$SOR = \frac{AOR * C_s}{a * (\beta C_{sd} - DO) * \theta^{(T-20)}}$$

C_s = DO saturation at Stnd Conditions
 = 9.092 * (1 + 0.4 * D / 34)
 = 11.02 mg/l

C_{sd} = DO saturation at design conditions
 C_{st} = DO saturation @ liquid temp & 1 sea level
 where : = C_{st} * (Fe + 0.4 * D / 34)

ElevFactor Fe = 1.00

Therefore, C_{sd} = 9.96 mg/l 298.15

Alpha, a 0.65 *
 D.O., mg/l 2.0 mg/l
 WW Temp T 25 °C

SWD, D 18.0 ft
 Beta, β 0.95 *
 Theta, θ 1.024

| | | | | |
|-------------------------------|----------|--------------|-------------------------------|-----------------|
| Standard Oxygen Required, SOR | = | 1,604 | lbs. O ₂ /day | 728 kg/d |
| SOR Peaking Factor | = | 1 | | |
| DESIGN SOR | = | 1,604 | lbs. O₂/day | 728 kg/d |

CYCLE TIMES

| | | | |
|---------------------|------|----------------|----------------------------|
| Batches per day | 4.00 | per SBR | |
| Complete Cycle time | 6.00 | hrs. per basin | |
| Fill time at ADF | 3.00 | hrs. | |
| Anoxic Fill time | 1.50 | hrs. | 50 % of FILL is anoxic. |
| Aerated Fill | 1.50 | hrs. | |
| React time | 1.50 | hrs. | 50 % of cycle is aerated. |
| Denite time | 0.00 | hrs. | |
| Settle Time | 0.75 | hrs. | 3.0 hrs. anoxic per cycle |
| Decant time | 0.65 | hrs. | |
| Idle time | 0.10 | hrs. | 3.0 hrs. aerated per cycle |

DIFFUSED AERATION SYSTEM SIZING

| | | | |
|----------------------------------|------|--------------------------|------------------------------|
| Aerator elevation | 1.0 | ft. | 0.30 m |
| Avg aerator submergence | 16.4 | ft. | 4.99 m |
| Total aeration time | 3.00 | hrs./cycle | |
| | 12.0 | hrs./basin/day | |
| SOR | 67 | lbs./hr/basin | 30 kg/hr |
| Normal gassing rate at ADF | 1.1 | SCFM / diffuser | 0.03 m ³ /min/dif |
| Max gassing rate | 2.2 | SCFM / diffuser | 0.06 m ³ /min/dif |
| Oxygen transfer efficiency (ADF) | 29.6 | % | |
| Design air flow | 218 | SCFM | 6 m ³ /m |
| Diffusers required per basin | 200 | diffusers | |
| Grids / Racks per basin | 1 | | |
| Diffuser per rack / grid | 200 | | |
| Diffuser mixing energy | 18.6 | scfm/1000ft ³ | |
| Diffuser density | 0.34 | scfm/ft ² | |

BLOWER SIZING DETAILS

| | | | | |
|---------------------------|---|-------|------------------------------|--------------------------|
| Operating blowers | = | 1 | per aerating basin | |
| Type of Blowers : | = | 1 | 1=PD, 2=Centrifugal, 3=Turbo | |
| Total Number of Blowers | = | 2 | including a spare | |
| Air flow per blower | = | 218 | SCFM | 371 m ³ /hr |
| Inlet losses | = | 0.3 | psig * | 2.07 kPa 0.02 bar |
| Net inlet pressure | = | 14.37 | psia (absolute) | 99.08 kPa 0.99 bar |
| Discharge piping losses | = | 0.7 | psig * | 4.83 kPa 0.05 bar |
| Losses at aerator | = | 0.75 | psig | 5.17 kPa 0.05 bar |
| Total discharge pressure | = | 8.83 | psig average | 60.89 kPa 0.61 bar |
| | | 9.11 | psig maximum | 62.81 kPa 0.63 bar |
| | | 6.88 | psig minimum | 47.46 kPa 0.47 bar |
| Site air flow required | = | 237 | ICFM average | 6.71 m ³ /min |
| BHp per blower | = | 13.4 | BHp/Blower | 10.0 BkW |
| | | | | 10.6 kW @ 94% ME |
| Blower BHp/aerating basin | = | 13.4 | BHp/Basin | 10.0 BkW |
| | | | | 10.6 kW @ 94% ME |

NO MIXERS REQUIRED

| | | | |
|--------------------------|----|---------------------------|-----------------|
| Number of mixers | 0 | per basin | |
| Type of mixer: | 0 | 1=Floating, 2=Submersible | |
| Hp per MG required | 25 | | |
| Total mixer energy req'd | 2 | Hp per basin | |
| Hp req'd per mixer | 0 | Hp per mixer | |
| Mixer size selected | 0 | Hp per mixer | 0.0 BkW |
| | | | 0.0 kW @ 94% ME |
| Total mixer BHp/basin | 0 | BHp/Mixer | 0.0 BkW |
| | | | 0.0 kW @ 94% ME |

DECANTERS

| | | |
|-------------------------------|----------------|----------------------|
| Cycles per day | 8 | |
| Avg TWL to BWL volume | 25,000 Gallons | 95 cubic meters |
| Max TWL to BWL volume | 25,000 Gallons | 95 cubic meters |
| Decant time | 0.65 hrs. | 39 minutes |
| Average decant flow | 641 GPM | 40 liters per second |
| Number of decanters per basin | 1 | |
| Average flow per decanter | 641 GPM | 40 liters per second |

SLUDGE WASTING

| | | |
|-------------------------------|-----------------------|----------------------|
| Dry solids (BOD estimate) | 353 lbs/day | 160 kg/d |
| Solids concentration in WAS | 0.85 % | |
| Total volume wasted per day | 4,976 gallons per day | 19 m3 / day |
| Wasting frequency | 4 per tank per day | |
| Volume wasted each period | 622 gallons | 2 m3 |
| Length of each wasting period | 2.5 minutes | |
| WAS pump rate | 250 gpm | 16 liters per second |
| WAS pump discharge head | 15 ft | 4.6 meters |
| WAS pump BHp | 2.5 BHp | 1.9 kW |

POWER SUMMARY

| Equipment | BHp/basin | Hours/day operating | kW hr/day | kW hr/annual |
|----------------------------|----------------|---------------------|-----------|--------------|
| SBR blowers | 13.4 | 24 | 239 | 87,324 |
| SBR mixers | 0.0 | 24 | 0 | 0 |
| Cost of power per kWhr | 0.05 | | Total | 239 |
| **Annual power cost | \$4,366 | | | 87,324 |

** does not include corrections for motor efficiency, VFD losses, V-belt losses, or power factor

*Denotes parameters assumed by Parkson. These parameters to be confirmed by Owner or Owner's representative

ALKALINITY REQUIREMENT CALCULATIONS:

7.14 mg/l consumed per mg/l nitrate, 3.57 mg/l recovery rate from denitrification
alkalinity calculations are based on 10% N concentration in WAS.

| | | | | | |
|------------------------------------|---|-----|-------|-------------------|---------|
| TKN oxidized to nitrate | = | 39 | mg/l | | |
| | = | 65 | lb/d | | 30 kg/d |
| Alkalinity req'd for nitrification | = | 280 | mg/l | | |
| Alkalinity recovered from denite | = | 0 | mg/l | 0 % Denite credit | |
| Alkalinity consumed | = | 280 | mg/l | | |
| Influent alkalinity concentration | = | 300 | mg/l* | | |
| Alkalinity as buffer | = | 50 | mg/l | | |
| Alkalinity addition required | = | 30 | mg/l | | |
| Chemical required | = | 50 | lb/d | as CaCO3 | 23 kg/d |
| | = | 40 | lb/d | of NaOH | 18 kg/d |
| | = | 84 | lb/d | of NaHCO3 | 38 kg/d |

DRAFT



Appendix H – Trojan UV Fit Details

DRAFT

DRAFT

WASTEWATER DISINFECTION
FILTERED IN-PIPE TREATMENT





Proven Trojan products. A new application.

Validated, chemical-free disinfection from the industry leader

Around the globe, wastewater treatment plants of all sizes are responding to the water quality and quantity demands of the communities they serve. As more municipalities adopt wastewater reuse policies and practices, wastewater treatment plants are required to treat effluent to higher levels – essentially eliminating all pathogens prior to reuse or discharge.

Depending on site and design conditions, wastewater treatment plants producing

filtered effluent sometimes prefer a disinfection solution using closed-vessel or pressurized UV reactors. The TrojanUVFit™ offers an effective and energy-efficient closed-vessel UV solution. This compact reactor is available in multiple configurations to treat a wide range of flow rates. The streamlined hydraulic profile of closed-vessel systems disinfect filtered effluent without breaking head in the treatment process. These benefits along with UV's ability to provide environmentally-friendly, chemical-free treatment for chlorine resistant microorganisms (such as *Cryptosporidium* and *Giardia*) make the

TrojanUVFit™ closed-vessel solution an attractive option for wastewater disinfection.

Trojan Technologies is an ISO 9001:2000 registered company that has been leading the UV disinfection market with open-channel solutions for wastewater disinfection (e.g. TrojanUV3000Plus™) in over 5,000 municipal installations worldwide – the largest UV installation base. The TrojanUVFit™, the latest addition to the Trojan product line, rounds out a complete portfolio of products for wastewater disinfection and reuse applications.

Key Benefits

TrojanUVFit™

Fully Validated Performance. System sizing is based on actual dose delivery verified through bioassay validation. Real-world, field performance data eliminates sizing assumptions and risks associated with theoretical dose calculations.

Compact Design. The small reactor footprint simplifies indoor retrofit installations and reduces construction costs.

Reliable, Proven Components. UV lamps, quartz sleeves, electronic ballasts, sensors and sleeve wiping system have been tested, proven reliable and are operating in hundreds of installations.

Design Flexibility. Reactors can be installed in parallel or in series, making it simple to incorporate redundancy or future expansion needs.

Wide Range of Flow Rates. Peak flow rates per reactor are suitable for either individual post-filter or manifold installation. Flows up to 7 MGD per reactor – the largest validated low-pressure lamp in-pipe wastewater system in the industry.

Validated Lamp Performance. Lamp output and aging characteristics validated through industry protocols and proven through years of operating experience.

Automatic Wiping. Automatic sleeve wiping saves operator's time and money. Ensures the maximum UV output is available for disinfection and minimizes energy consumption.

Global support. Local service. Trojan's comprehensive network of certified service providers offers fast response for service and spare parts.

Guaranteed Performance and Comprehensive Warranty. Trojan systems include a Lifetime Disinfection Performance Guarantee. Ask for details.

TROJAN UVFIT™

Designed for efficient, reliable performance

System Control Center

The microprocessor or PLC-based controller continuously monitors and controls UV system functions. SCADA communication via ModBus for remote monitoring, control and dose pacing is available. Programmable digital and analog I/O capabilities can generate unique alarms for individual applications and send signals to operate valves and pumps.

Sleeve Wiping System

Automatic sleeve wiping system operates on-line without interrupting disinfection. The wiping sequence occurs automatically at preset intervals without operator involvement.

Amalgam Lamps

High-output amalgam lamps are energy-efficient and save operating costs due to reduced electrical consumption. Lamps are located within protective quartz sleeves with easy access from the service entrance.

UV Intensity Sensor

Highly accurate, photodiode sensor monitors UV output within the reactor. The sensor ensures UV light is fully penetrating the water for complete disinfection.



Compact reactors designed for high flow rates also available. This reactor contains lamps in both ends of the reactor. Multiple inlet and outlet flange orientations are available.

Power Distribution Center (PDC)

The PDC panel distributes power to the reactor, UV intensity sensor and sleeve wiping system. The panel also houses high-efficiency, variable-output (60 – 100% power) or constant-output ballasts with proven performance in hundreds of installations around the world.



End Cap

The end cap protects and isolates connections for components such as lamps, sleeves and wiping system. Power is automatically disconnected if end cap is removed thereby ensuring a safe working environment for operators.

UV Reactor

Electropolished 316L stainless steel chamber available in multiple configurations for a wide range of flow rates. Optional flange orientations allow reactors to fit into existing piping galleries or tight spaces.

Regulatory-Endorsed Bioassay Validation

Field testing ensures accurate dose delivery

Benefits:

- Validated in accordance with industry protocols established by National Water Research Institute (NWRI)
- Performance data is generated from actual field testing over a wide range of flow rates and water quality (UV transmission)
- Bioassay testing offers peace of mind and improved public and environmental safety due to verified dose delivery – not theoretical calculations

Compact Reactor for Installation Flexibility

Efficient, cost-saving design enables retrofit or new construction

Benefits:

- Compact footprint simplifies installation and minimizes related capital costs – ideal for retrofit and new construction applications
- Lamps and sleeves are fully serviceable from the reactor end – allowing the system to be installed against walls, other equipment or piping
- Low headloss design simplifies integration into existing process, and avoids additional pumping and associated capital and operational costs
- Multiple flange orientations available – increasing design flexibility



Reactors can be installed in parallel or in series for increased design and installation flexibility.

Amalgam Lamps Require Less Energy

Maintain maximum output and reduce O&M costs

Benefits:

- Each lamp draws 250 Watts
- Trojan's amalgam lamps maintain 98% output during entire lamp life – 20% less decline than competitive UV lamps
- Validated performance provides assurance of reliable dose delivery and prolonged lamp life
- Deliver consistent and stable UV output over a wide range of water temperatures

Built for Reliable Performance and Easy Maintenance

Designed for trouble-free operation and minimal service

Benefits:

- Routine procedures, including lamp changeouts are simple and require minimal time – reducing maintenance costs
- Access to internal components (lamps, sleeves, cleaning system) through service entrance at one end.
- Service entrance and connections isolated and protected by end cap
- Intensity sensor continuously monitors UV output to ensure dose delivery



The TrojanUVFit™ lamps are easily replaced in minutes without the need for tools.

Robust Sleeve Wiping System

Automatic wiping system maintains consistent dose delivery

Benefits:

- Wiping system minimizes fouling of quartz sleeves
- Ensures consistent UV dose delivery and optimum performance
- Automatic wiping occurs while the lamps are disinfecting, reducing downtime
- Optional off-line chemical cleaning to reduce maintenance associated with manual cleaning

User-Friendly Operator Interface

Touch-screen display allows easy operation and monitoring

Benefits:

- Microprocessor or PLC-based system controls all functions and dose pacing to minimize energy use while maintaining required UV dose
- Controller features intuitive, graphical display for at-a-glance system status
- Controller communicates with plant SCADA systems for centralized monitoring of performance, lamp status, power levels, hours of operation and alarm status

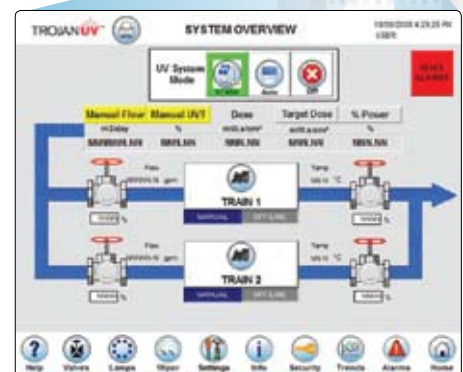

The PLC-based controller combines sophisticated system operation and reporting with an operator-friendly, touch screen display.

| System Specifications | | | | | | |
|--|--|-----------------|------------------|--|-------------------|-------------------|
| Model | 04AL20 | 08AL30 | 18AL40 | 32AL50 | 72AL75 | D72AL75 |
| Number of Lamps | 4 | 8 | 18 | 32 | 72 | 144 |
| Lamp Type | High-efficiency, High-output, Low-Pressure Amalgam | | | | | |
| Sleeve Wiping | Automatic Wiping System (Optional Off-line Chemical Cleaning) | | | | | |
| Ballast | Electronic, constant output (100% power) | | | Electronic, variable output (60 to 100% power) | | |
| Reactor Chamber | | | | | | |
| Materials of Construction | 316L Stainless Steel | | | | | |
| Standard Flange Size (ANSI/DIN), inches (mm) | 6 (150) | 8 (200) | 10 (250) | 12 (300) | 20 (500) | 20 (500) |
| Outlet Flange Orientation | Multiple orientations available 3, 6, 9, or 12 o'clock position | | | | | |
| Approx. Reactor Length, inches (mm) | 80 (2032) | 80 (2032) | 80 (2032) | 90 (2286) | 90 (2286) | 152 (3861) |
| Max. Operating Pressure, PSI (bar) | 150 (10) | 150 (10) | 150 (10) | 100 (6.8) | 65 (4.5) | 65 (4.5) |
| Dry Reactor Weight, lbs (kg) | 107 (49) | 210 (95) | 400 (181) | 1600 (726) | 2100 (953) | 3700 (1678) |
| Wet Reactor Weight, lbs (kg) | 232 (105) | 480 (218) | 877 (398) | 2200 (998) | 3700 (1678) | 7200 (3265) |
| Power Distribution Center | | | | | | |
| Electrical Supply | 240 VAC, 1 phase, 2 wire + GND, 50/60 Hz | | | 480Y/277 V, 3 phase, 4 wire + GND, 60 Hz | | |
| Dimensions, inches | 24 x 24 x 10 | 30 x 24 x 10 | 36 x 48 x 10 | 40 x 78 x 18 | 48 x 86 x 24 | 96 x 86 x 24 |
| Dimensions, mm | 610 x 610 x 254 | 762 x 610 x 254 | 914 x 1219 x 254 | 1016 x 1981 x 457 | 1219 x 2184 x 610 | 2438 x 2184 x 610 |
| Available Materials of Construction | Mild Painted Steel 304 Stainless Steel | | | | | |
| Panel Rating | NEMA 3R or 4X | | | NEMA 12 or 4X | | |
| System Control Center | | | | | | |
| Controller | Microprocessor | | | PLC-based | | |
| Location | Built into Power Distribution Center (PDC) | | | Stand-alone Panel | | |
| Electrical Supply | N/A (see PDC) | | | 120 V, 1 phase, 2 wire + GND, 60Hz | | |
| Panel Rating | N/A (see PDC) | | | NEMA 12 or 4X | | |
| Typical Outputs Provided | Reactor status, common alarms and SCADA communication | | | | | |

Find out how your wastewater treatment plant can benefit from proven TrojanUVFIT™ solutions. Contact us today.

Head Office (Canada)
3020 Gore Road
London, Ontario, Canada N5V 4T7
Telephone: (519) 457-3400
Fax: (519) 457-3030
www.trojanuv.com

Trojan UV Technologies UK Limited (UK): +44 1905 77 11 17
Trojan Technologies (The Netherlands): +31 70 391 3020
Trojan Technologies (France): +33 1 6081 0516
Trojan Technologies Espana (Spain): +34 91 564 5757
Trojan Technologies Deutschland GmbH (Germany): +49 6024 634 75 80
Hach/Trojan Technologies (China): 86-10-65150290

Printed in Canada. Copyright 2008. Trojan Technologies London, Ontario, Canada.
No part of this publication may be reproduced, stored in a retrieval system, or transmitted in any form or by any means without the written permission of Trojan Technologies.

Products in this publication may be covered by one or more of the following patents: Can. 2,117,004; Can. 2,239,925; US 5,418,370; US RE36,896; US 6,342,188; US 6,564,157; US 6,773,604; US 6,646,269; US 6,659,431; US 6,500,346.
Other patents pending.
OA-E-M&S-5.2-BR-CA0003-0908

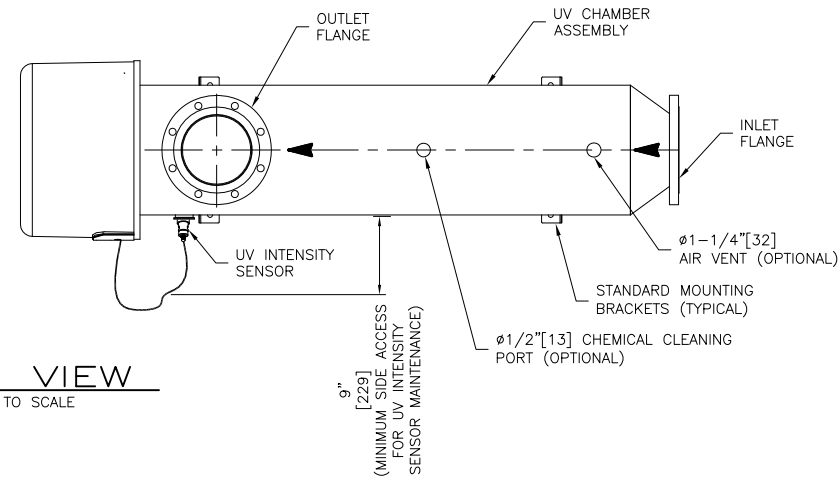

TOP VIEW
SCALE: NOT TO SCALE

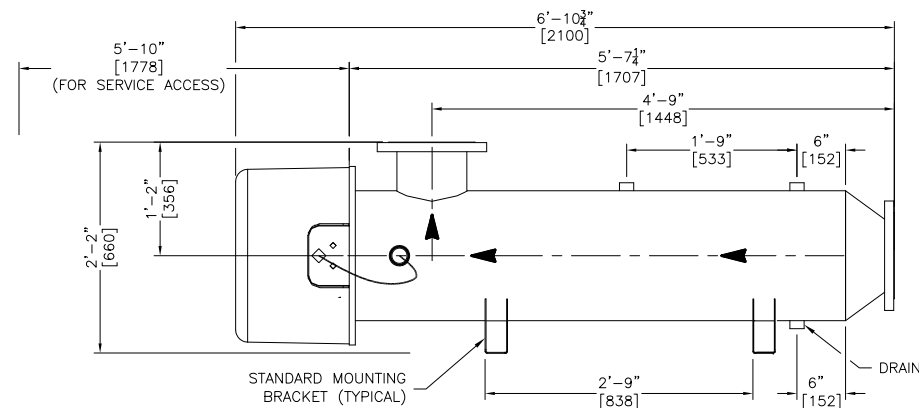

FRONT VIEW
SCALE: NOT TO SCALE

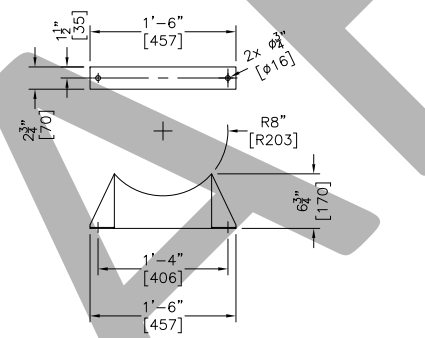

DETAIL A-A
SCALE: NOT TO SCALE (STANDARD MOUNTING BRACKETS)

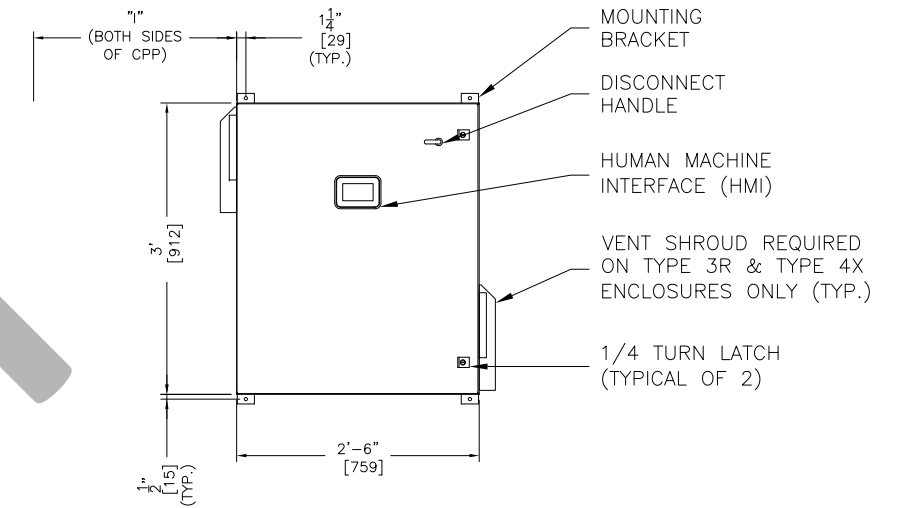

FRONT VIEW OF CPP
SCALE: NOT TO SCALE

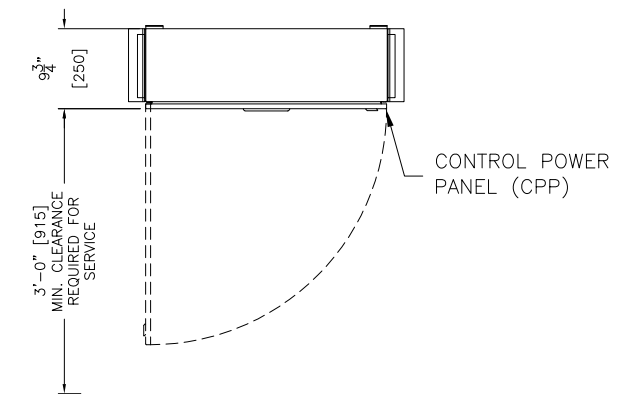

TOP VIEW OF CPP
SCALE: NOT TO SCALE

| MODEL | LAMP LENGTH | UV CHAMBER ASSEMBLY DIAMETER | # LAMPS AVAILABLE | FLANGE TYPE | FLANGE SIZE | # BOLT HOLES IN FLANGE | WIPING SYSTEM |
|--------|-------------|------------------------------|-------------------|-------------|----------------------|------------------------|------------------------------|
| 18AL40 | LONG | 16" [400] | 18 | ANSI/DIN | 10" [250] (STANDARD) | 12 | AMWS (STANDARD) |
| | | | | | 8" [203] (OPTIONAL) | 8 | NO. WIPING SYSTEM (OPTIONAL) |

NOTES:

- 1/ MAXIMUM OPERATING PRESSURE TO BE 150 psi [10 BAR].
 - 2/ STANDARD INTERCONNECTING CABLE LENGTH TO BE 15ft [4.5m].
 - 3/ [] INDICATES MILLIMETERS UNLESS OTHERWISE SPECIFIED.
 - 4/ CONNECTION SEALS AND HARDWARE TO BE SUPPLIED BY CUSTOMER.
 - 5/ MOUNTING AND SAMPLING PORTS ARE TO BE SUPPLIED BY THE CUSTOMER.
 - 6/ CLEARANCES FOR WIPING SYSTEMS FALL WITHIN CLEARANCES REQUIRED FOR SLEEVE REMOVAL.
 - 7/ OUTLET ORIENTATION OPTIONS : TOP (STANDARD), LEFT, RIGHT, AND BOTTOM. TOP OUTLET IS SHOWN FOR CLARITY.
- * INDICATES DIMENSIONS SHOWN ARE SUBJECT TO CHANGE DEPENDING ON SITE SPECIFIC REQUIREMENTS.

| | | | |
|---|---|------------------|-----------------------------------|
| <p>CONFIDENTIALITY NOTICE Copyright© 2016 by Trojan Technologies. All rights reserved. No part of this document may be reproduced, stored in a retrieval system, or transmitted in any form, without the written permission of Trojan Technologies.</p> | DESCRIPTION: STD, TROJANUVFIT 18AL40 SYSTEM | | STD. DRAWING NO. FT0006 |
| | DRAWN BY : TIY/MMB/MJU | DATE : 16NO22 | REFERENCE NO. N/A |
| | CHECKED BY : MVW | DATE : 16NO22 | DWG. NO. D01 |
| | APPROVED BY : CW | DATE : 16NO22 | REV. D |
| SCALE (11x17) : 1/2" = 1'-0" | | LOG NUMBER : N/A | |



Eureka, CA | Arcata, CA | Redding, CA | Willits, CA | Coos Bay, OR | Klamath Falls, OR

www.shn-engr.com