



# Safety Glazing (Tempered Windows)

This handout describes when the Humboldt County Building Division requires safety glazing or tempered windows per the 2019 California Residential Code. Safety glazing is required to prevent injury caused by broken glass. In general, it is required around hazardous places such as wet areas, near doors, near stairs, windows close to walking surfaces, and windows in locations with a high wildfire risk.

## Wet Surfaces | Safety Glazing

[R308.4.5 Glazing and Wet Surfaces](#). This section applies to windows within walls containing OR facing hot tubs, spas, whirlpools, saunas, steam rooms, bathtubs, showers and indoor or outdoor swimming pools.

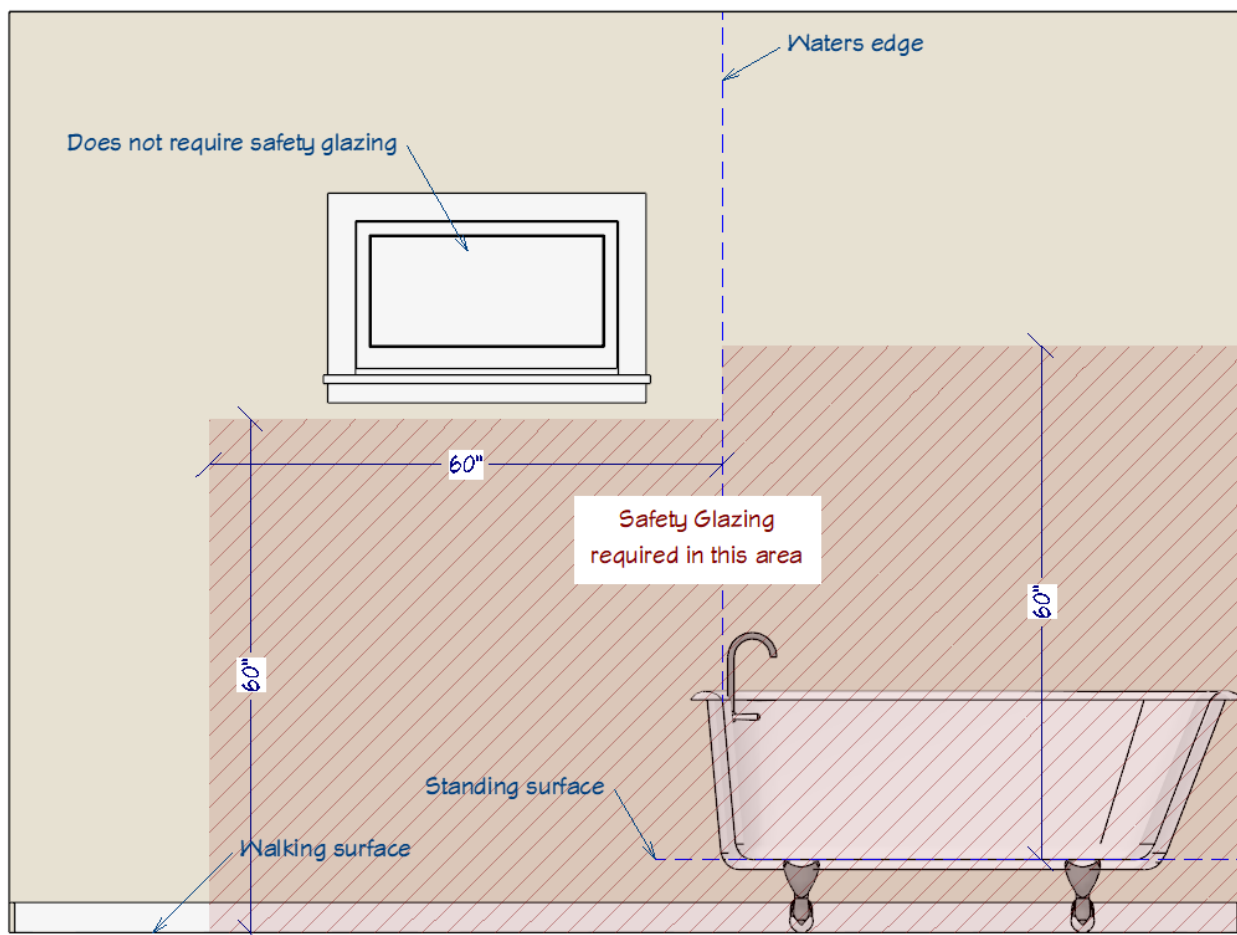

### Exceptions

1. Glazing that is more than 60 inches (1524 mm), measured horizontally and in a straight line, from the water's edge of a bathtub, hot tub, spa, whirlpool, or swimming pool or from the edge of a shower, sauna, or steam room.

## Adjacent to Doors | Safety Glazing

[R308.4.2 Glazing Adjacent to Doors](#) and [R308.4.1 Glazing in Doors](#). If any part of the glass pane is within the red zone safety glazing will be required.

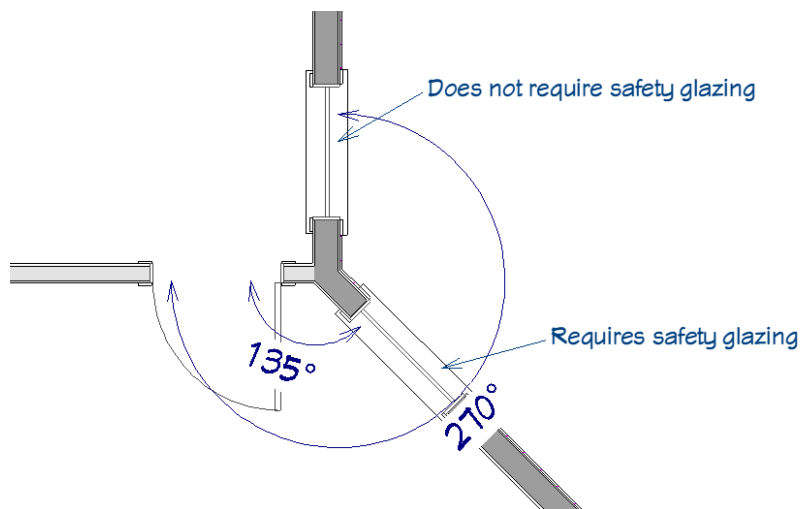
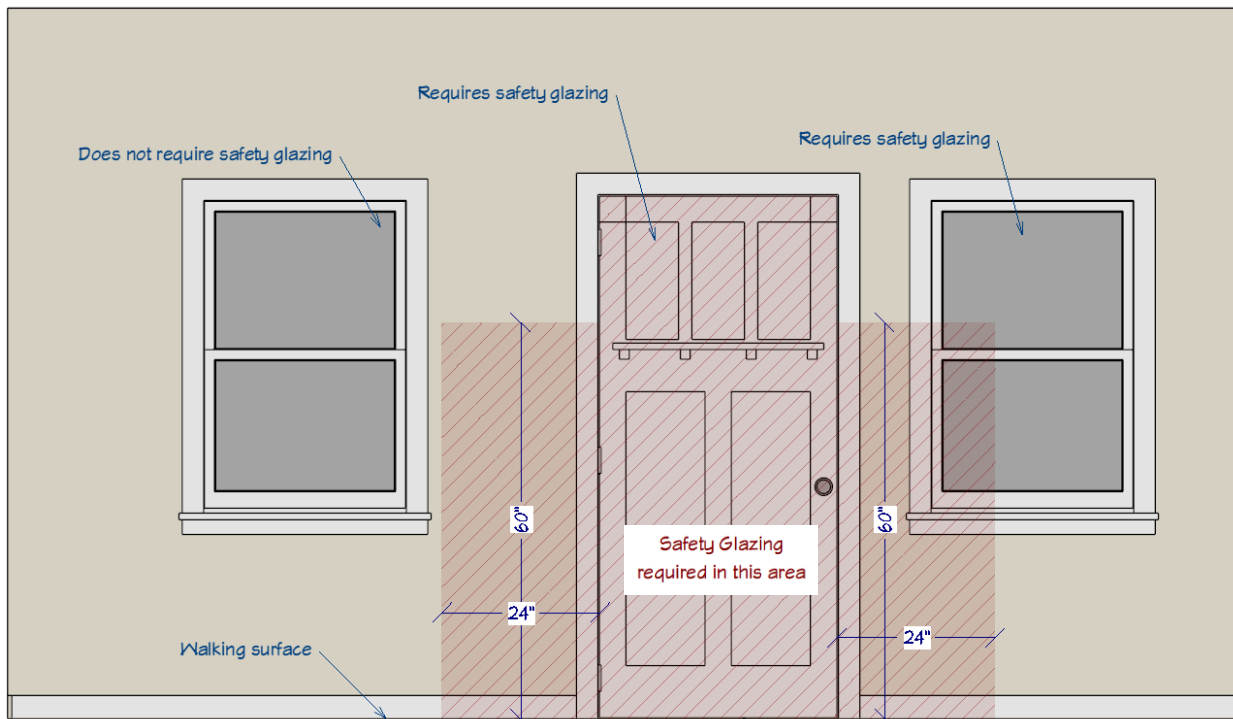

### Exceptions

1. Decorative glazing.
2. Where there is an intervening wall or other permanent barrier between the door and the glazing.
3. Where access through the door is to a closet or storage area 3 feet (914 mm) or less in depth. Glazing in this application shall comply with Section R308.4.3.
4. Glazing that is adjacent to the fixed panel of patio doors.

# Adjacent to Stairs | Safety Glazing

[R308.4.6 Glazing Adjacent to Stairs and Ramps](#) and [R308.4.7 Glazing Adjacent to the Bottom Stair Landing](#). If any part of the glass pane is within the red zone safety glazing will be required.

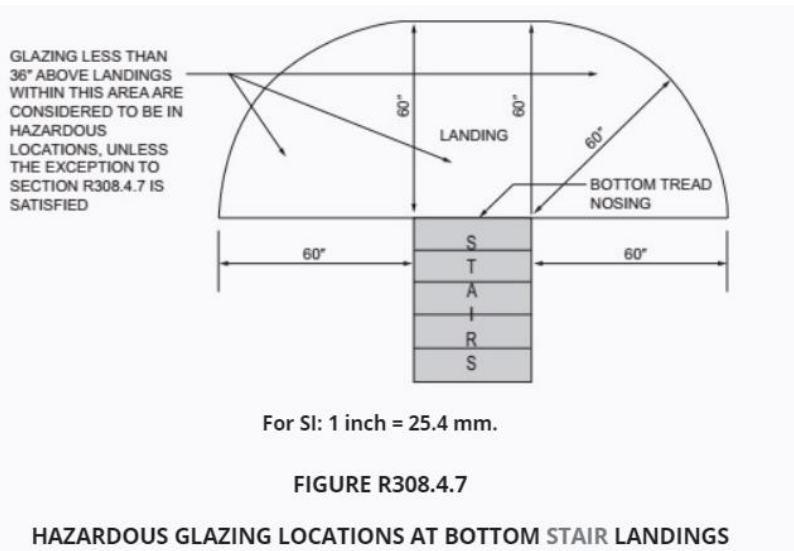
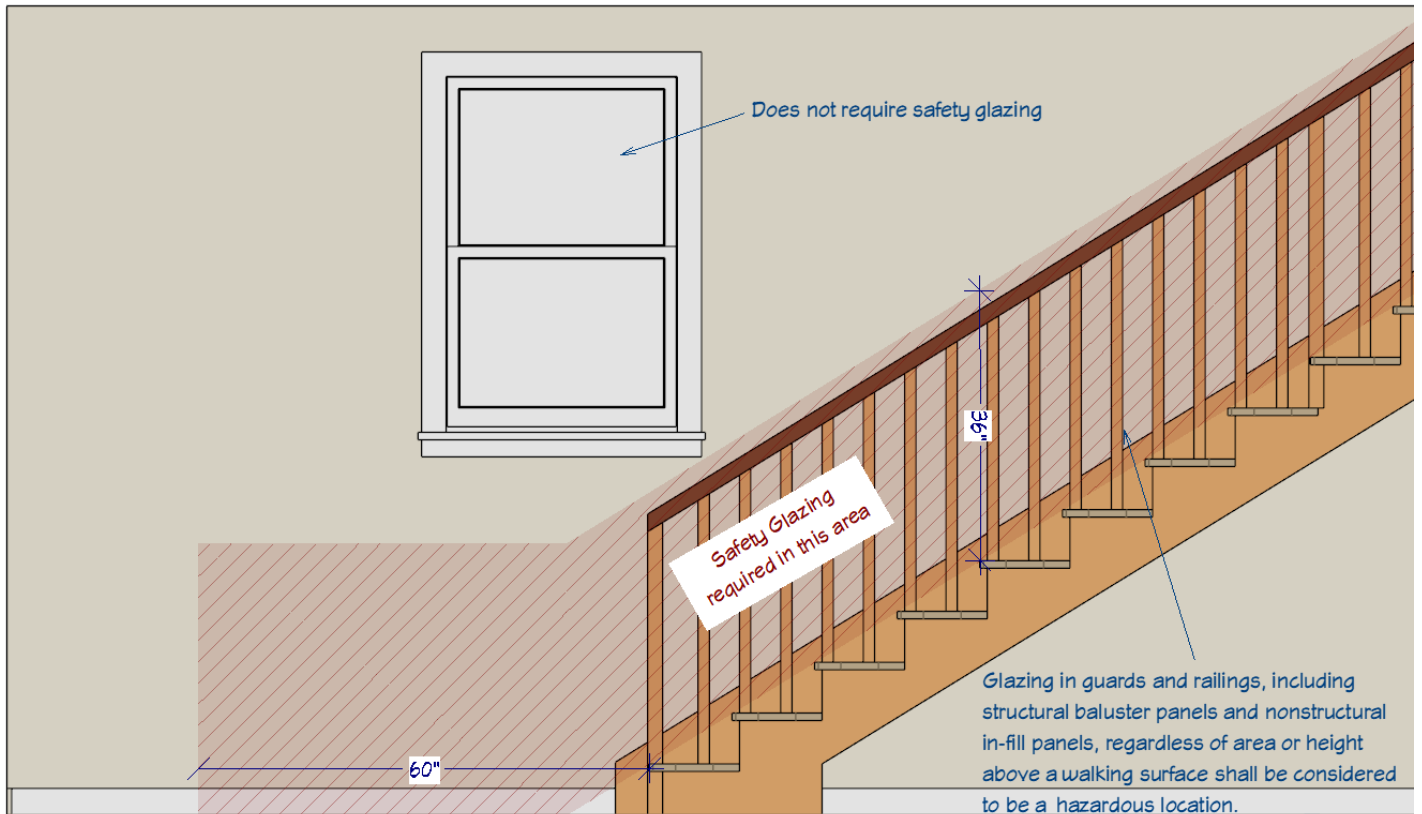

## Exceptions

1. Where glazing is adjacent to a walking surface and a horizontal rail is installed at 34 to 38 inches (864 to 965 mm) above the walking surface. The rail shall be capable of withstanding a horizontal load of 50 pounds per linear foot (730 N/m) without contacting the glass and have a cross-sectional height of not less than 1 1/2 inches (38 mm).
2. Glazing 36 inches (914 mm) or more measured horizontally from the walking surface.

## Close to Walking Surface | Safety Glazing

[R308.4.3 Glazing in Windows](#). If all the conditions outlined in the image below are true, then safety glazing will be required.

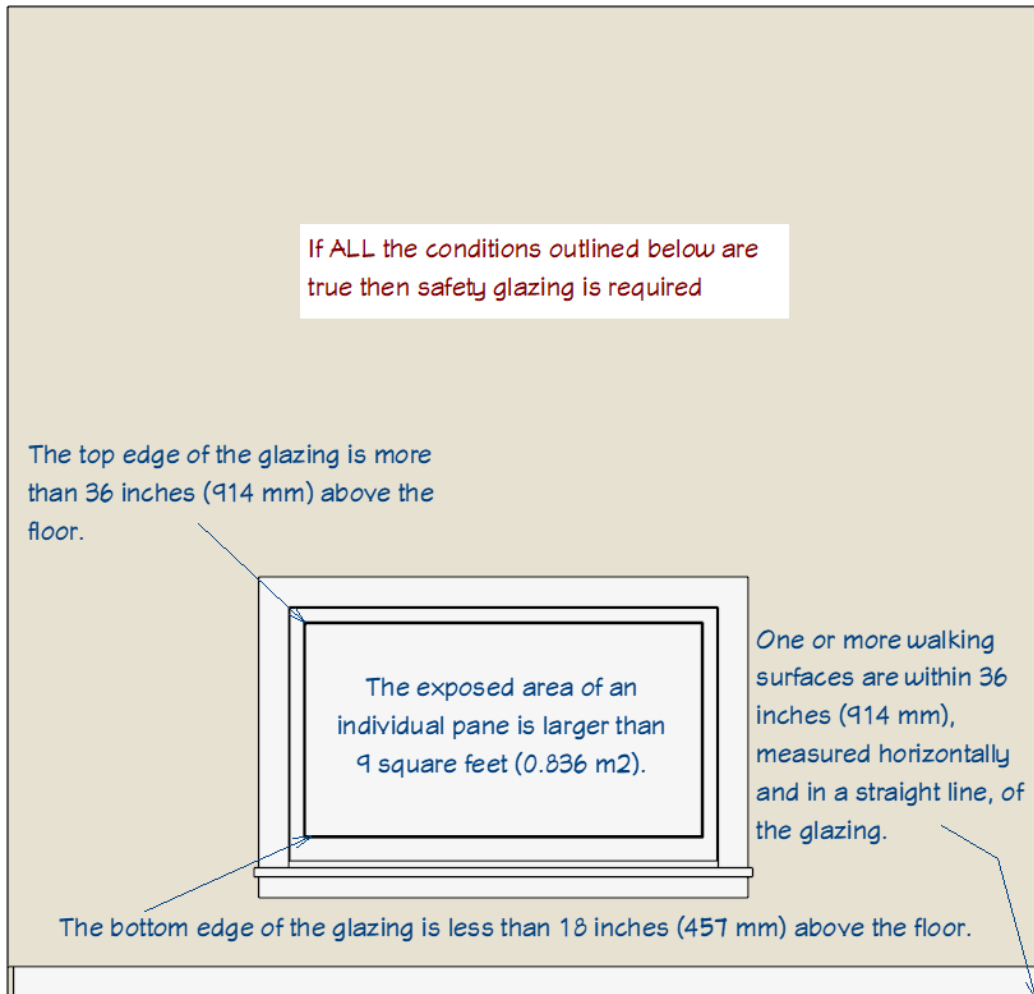

### Exceptions

1. Decorative glazing.
2. Where glazing is adjacent to a walking surface and a horizontal rail is installed 34 to 38 inches (864 to 965 mm) above the walking surface. The rail shall be capable of withstanding a horizontal load of 50 pounds per linear foot (730 N/m) without contacting the glass and have a cross-sectional height of not less than 1 1/2 inches (38 mm).
3. Outboard panes in insulating glass units and other multiple glazed panels where the bottom edge of the glass is 25 feet (7620 mm) or more above grade, a roof, walking surfaces or other horizontal [within 45 degrees (0.79 rad) of horizontal] surface adjacent to the glass exterior.

## Wildland Urban Interface (WUI) | Safety Glazing

If your proposed development is required to comply with [exterior wildlife exposure](#) requirements then all your windows will be required to be tempered on at least one side. To see if this requirement pertains to your project follow the below steps.

1. Open Humboldt Counties [Web GIS](#).
2. Input your accessor parcel number (APN) in the search bar.

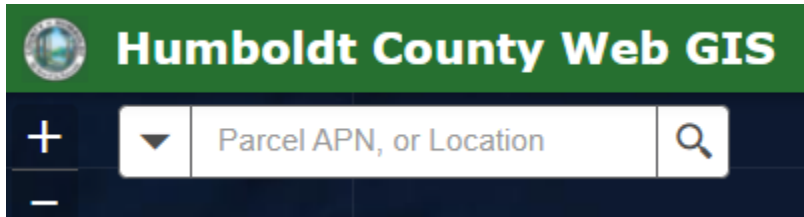

3. Check the following layer list checkboxes.

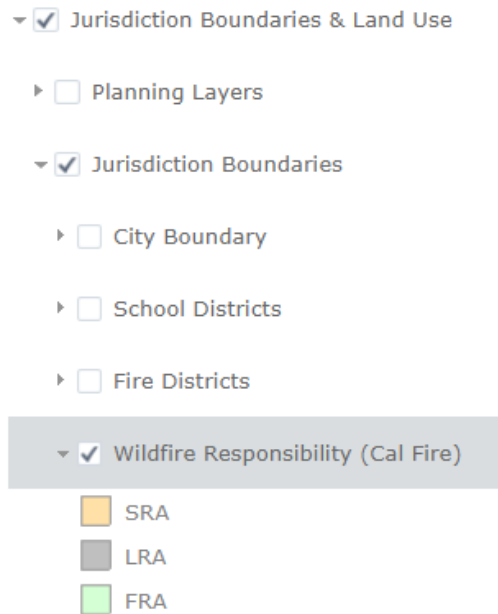

4. If you see the below gradient covering your parcel, then you are in the SRA and you can proceed to the following step. If you are not in the SRA, you will not need to comply with WUI requirements.



5. Reference section [R337.1.3 Application](#) and [R337.1.3.1 Application Date and Where Required](#) of the California Residential Code to see if your proposed project fits the criteria. If it does you will need to comply with WUI requirements and provide tempered windows.